



US Army Corps  
of Engineers  
Rock Island District

DRAFT



Defense Environmental Restoration Program  
for  
Formerly Used Defense Sites  
Ordnance and Explosive Waste

# Archives Search Report

## FINDINGS

for  
the former

### CAMP CROFT ARMY TRAINING FACILITY

SPARTANBURG, SOUTH CAROLINA  
Project Number I04SC001603

September 1993

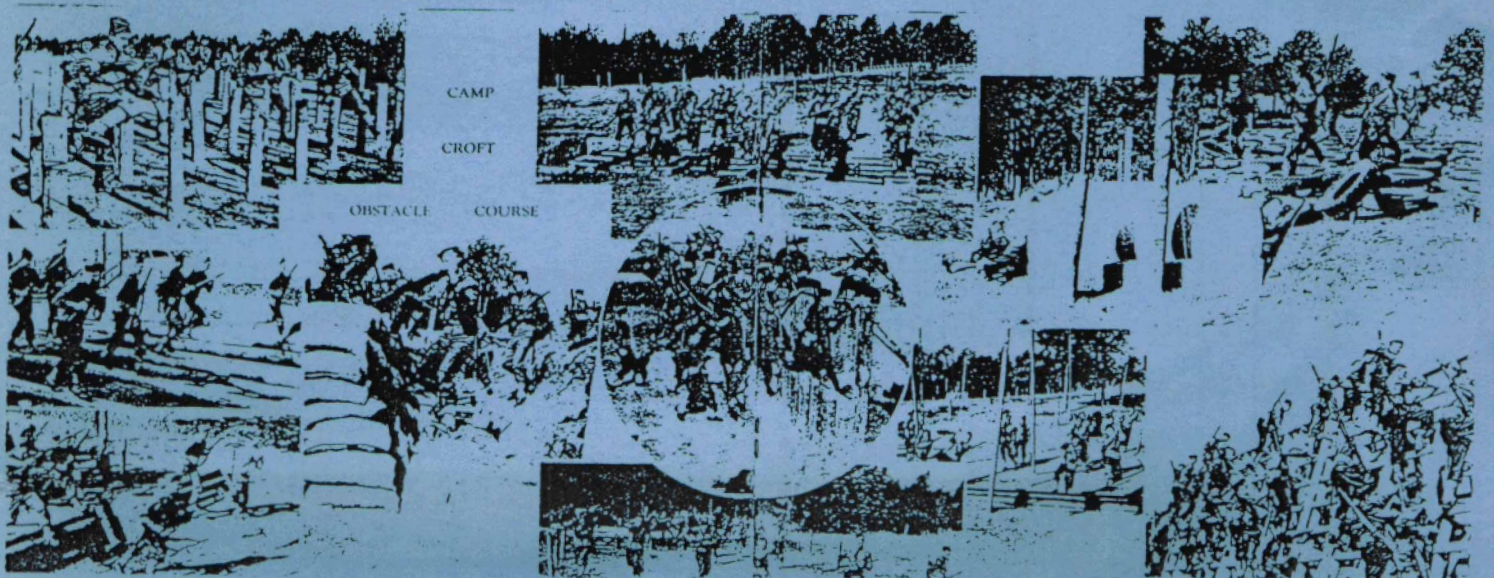

DRAFT

DEFENSE ENVIRONMENTAL RESTORATION PROGRAM  
for  
FORMERLY USED DEFENSE SITE

**FINDINGS**

ORDNANCE AND EXPLOSIVE WASTE  
ARCHIVES SEARCH REPORT  
FOR  
FORMER CAMP CROFT ARMY TRAINING FACILITY  
SPARTANBURG, SOUTH CAROLINA  
PROJECT NUMBER I04SC001603

September 1993

Prepared For

U.S. Army Corps of Engineers  
Huntsville Division  
ATTN: CEHND-PM-OT  
P.O. Box 1600  
Huntsville, Alabama 35807-4301

Prepared By

U.S. Army Corps of Engineers  
Rock Island District  
ATTN: CENCR-ED-DN  
P.O. Box 2004  
Rock Island, Illinois 61204-2004

and

U.S. Army Defense Ammunition  
Center and School  
ATTN: SMCAC-ES  
Savanna, Illinois 61074-9639

## EXECUTIVE SUMMARY

The purpose of this report is to present the findings of a records search and site inspection for potential ordnance contamination located at the former Camp Croft Army Training Facility. The site is located approximately five miles southeast of Spartanburg, South Carolina by way of State Hiway 176 which roughly parallels the northeast boundary of the former camp. This report was authorized as part of the Defense Environmental Restoration Program for Formerly Used Defense Sites (DERP-FUDS).

A records search provided information on types of munitions utilized and stored as part of the mission at Camp Croft. There were firing ranges in place at the camp for rifle, pistol, machine gun, mortar (60 mm and 81 mm) as well as anti-aircraft, and anti-tank live-fire training. An ammunition storage area, and training facilities for gas warfare and hand grenade exercises were also in use there.

During the period 24-26 March 1993 an on-site investigation (SI) was performed at the old Camp Croft area to visually verify records search data on the presence or absence of Ordnance and Explosive Waste (OEW) contamination. This inspection defined the following four areas that have or may have OEW contamination: the training range impact area, the grenade court, the former troop cantonment area (mostly residential now), and the gas chamber and gas obstacle course. Numerous samples of surface OEW were found by the SI team at the training range impact area which encompasses most of what is now Croft State Park. The samples included 30 caliber bullets and parts of trench mortar ordnance.

Interviews included a park ranger who claims to have personally found numerous OEW items such as projectiles, mortar rounds, grenades, and illumination rounds on the park grounds. Other interviews relate to "second-hand" accounts of grenades and gas training components being located. The only OEW viewed by the team was the samples found on the ground at the former impact area during the site inspection and an Army ground signal found by one of the interviewees in the company of the team. Documented records on previously found ordnance lend credible evidence that OEW contamination exists through out various locations at the former Camp Croft Training Facility.

Both the documented and the on-site visual evidence of OEW at this site indicates remediation is required. Additional follow-up investigations are also recommended to assess any possible hazardous toxic and radiological waste (HTRW) and associated cleanup requirements.

ORDNANCE AND EXPLOSIVE WASTE  
 ARCHIVES SEARCH REPORT  
 FOR  
 FORMER CAMP CROFT ARMY TRAINING FACILITY  
 SPARTANBURG, SOUTH CAROLINA  
 PROJECT NUMBER I04SC001603

ACKNOWLEDGMENTS				
The following persons provided support, as indicated.				
Function	Name	Title	Organization	Telephone
Team Leader	Jodi L. Bausman	Ammunition Specialist	CENCR-ED-DN	(309) 794-5257
On-site Assessment	Mike Harper	Ammunition Specialist (QASAS)	SMCAC-ESL	(815) 273-8749
Technical Library Search	Jacqueline S. Bey	Admin. Librarian	SMCAC-ESM	(815) 273-8772
Project Engineer	Daniel J. Holmes	Professional Engineer	CENCR-ED-DN	(309) 794-5480
Geographic District	Wayne Bogan	Biologist	CESAC-EN-E	(803) 724-4366
Industrial Hygiene	Robert Platt	Industrial Hygienist	HSXP-FS-RIA	(309) 782-0806
Admin. Support	Rebecca J. Stotler	Computer Clerk	SMCAC-ESL	(815) 273-8762
CADD Support	Heather Steele	Student Technician	CENCR-ED-DN	(309) 794-5177

ORDNANCE AND EXPLOSIVE WASTE  
ARCHIVES SEARCH REPORT  
FOR  
FORMER CAMP CROFT ARMY TRAINING FACILITY  
SPARTANBURG, SOUTH CAROLINA  
PROJECT NUMBER I04SC001603

**FINDINGS**

TABLE OF CONTENTS

Section	Page
1. INTRODUCTION .....	1
a. Subject and Purpose	
b. Scope	
2. PREVIOUS INVESTIGATIONS .....	1
a. 1984 Site Survey of Camp Croft	
b. 1990 Site Screening Investigation: Camp Croft landfill	
c. 1991 Preliminary Assessment	
3. SITE DESCRIPTION .....	2
a. Existing Land Usage	
b. Meteorological Data	
c. Geology and Soil	
d. Hydrology	
e. Cultural Resources	
4. HISTORICAL ORDNANCE USAGE ON-SITE .....	5
a. Chronological Site Summary	
b. Ordnance Related Records Review	
c. Interviews with Site Related Personnel	
5. REAL ESTATE .....	10
a. Confirmed Formerly Used Defense Sites	
b. Potential Formerly Used Defense Sites	
6. SITE INSPECTION .....	11
a. General Procedures and Safety	
b. Training Range Impact Area	
c. Gas Chambers and Gas Obstacle Course Area	
d. Cantonment Area	
e. Grenade Court	

7.	EVALUATION OF ORDNANCE PRESENCE .....	14
	a. General Procedures	
	b. Training Range Impact Area	
	c. Gas Chambers and Gas Obstacle Course Area	
	d. Cantonment Area	
	e. Grenade Court	
8.	TECHNICAL DATA OF ORDNANCE AND EXPLOSIVES.....	16
9.	EVALUATION OF OTHER SITE HAZARDS .....	26
	a. Hazardous, Toxic, and Radiological Waste	
	b. Building Demolition/Debris Removal	

APPENDICES

A.	ACKNOWLEDGMENTS OF ORGANIZATIONS/PERSONNEL	
B.	GENERAL REFERENCES AND/OR ABSTRACTS .....	
C.	GLOSSARY .....	
D.	TEXTS/MANUALS.....	
E.	REPORTS/STUDIES .....	
F.	LETTERS/MEMORANDUMS/CORRESPONDENCE .....	
G.	REAL ESTATE DOCUMENTS .....	
H.	NEWSPAPER/JOURNALS .....	
I.	INTERVIEWS .....	
J.	PRESENT SITE PHOTOGRAPHS.....	
K.	HISTORICAL PHOTOGRAPHS .....	
L.	HISTORICAL MAPS/DRAWINGS .....	
M.	REPORT DISTRIBUTION .....	

REPORT PLATES

1.	SITE MAP .....	
2.	FACILITY LAYOUT/PHOTO LOCATIONS .....	
3.	CANTONMENT, ADMINISTRATIVE AREA	
4.	AMMO STORAGE BUNKERS/MOVING TARGET AREA	
5.	HENNINGSTON ROAD AREA.....	
6.	CRAIG LAKE AREA	
7.	FIRING RANGE IMPACT AREA Vs CROFT STATE PARK	

ORDNANCE AND EXPLOSIVE WASTE  
ARCHIVES SEARCH REPORT  
FOR  
FORMER CAMP CROFT ARMY TRAINING FACILITY  
SPARTANBURG, SOUTH CAROLINA  
PROJECT NUMBER I04SC001603

1. INTRODUCTION

a. **Subject and Purpose**

(1) This report presents the findings of a historical records search and site inspection for ordnance and explosive waste (OEW) presence located at Former Camp Croft Army Training Facility near Spartanburg, South Carolina. See plate 1 for general site location map. The investigation was performed under the authority of the Defense Environmental Restoration Program for Formerly Used Defense Sites.

(2) The purpose of this investigation was to characterize the site for potential OEW contamination utilizing historical records, interviews and on-site visual inspection results.

b. **Scope**

(1) The investigation focused on 19,044.46 acres that were used as the Camp Croft cantonment and training areas.

(2) This report presents the site history, site description, real estate ownership information, results of a visual site inspection, confirmed ordnance presence based on available records, the site inspection, and evaluation of potential ordnance contamination based on site ordnance components and site information.

2. PREVIOUS INVESTIGATIONS

a. **1984 Site Survey of Camp Croft**

An on site survey of the former Camp Croft area was completed in August of 1984 by a combined team from SACEN and SARE (Charleston District, Environmental and Real Estate Divisions). The visit determined that there was no building demolition and debris removal (BD/DR) responsibility incurred by DOD at this site. A project was however recommended that included further investigation of the Camp Croft area to define the extent of any waste or ordnance materiel contamination. The report included interview statements on "the potential for unexploded and dangerous bombs, shells, rockets, mines, and charges either upon or below the surface" and to "a great deal of unexploded ordnance" which was uncovered and hauled away during grading of the country golf club course (see document E-4).

**b. 1990 Site Screening Investigation: Camp Croft Landfill**

A March 1990 report by the Bureau of Solid and Hazardous Waste Management, Department of Health and Environmental Control provides data on a site screening visit to the Camp Croft landfill (appendix B-5). It includes details on a hydrogeologic review of the landfill and laboratory analyses of groundwater samples collected during the Site Screening Investigation. The landfill is located approximately 5 miles southeast of the intersection of South Carolina (S.C.) state highways 295 and 56 and approximately 1.0 mile east-northeast of the intersection of S.C. highway 56 and a road leading to Flemming cemetery in the Golightly community. A detailed rough sketch of the landfill location with monitoring wells is provided at document E-5 (see appendix B-5). This is a domestic waste landfill first used in 1971. No records were available to indicate any use of this landfill by the Department of Defense or the existence of any previous Army landfill on this site.

**c. 1991 Preliminary Assessment**

A Preliminary Assessment of the Former Camp Croft Army Training Facility was conducted by CESAC with Findings and Determination (FDE) dated 25 November 1991. The site was determined to be eligible under the DERP-FUDS program. Based on this preliminary assessment, three separate projects were identified (see table 2-1 and documents F-3 thru F-5).

TABLE 2-1 1991 PRELIMINARY ASSESSMENT			
Project Number	DERP Category	Present Phase	Comments
I04SC001601	CON/HTRW	RD/RA	Locate drums: overpack, dispose of, & restore
I04SC001602	HTRW	RI/FS (Scheduled f/FY94)	Buried drums: determine contamination, remediate, & restore
I04SC001603	OEW	RI	Locate, remove & restore

**3. SITE DESCRIPTION**

**a. Existing Land Usage**

(1) The original 19,044.46 acres which made up Camp Croft were acquired by the United States between 1941 and 1944. The camp was located approximately five miles southeast of the city of Spartanburg in the southeast quadrant of Spartanburg county (see plate 1 and maps L-1, L-2, and L-3).



(2) The entire Camp Croft acreage was declared excess to the War Assets Administration in 1947. Over the next 3 years the land was disposed of piecemeal by sale or quitclaim to organizations and business interests and former owners (see documents G-2, G-3, G-4 and map L-13). One of the most significant disposal actions was 7,088.08 acres of fee land conveyed by quitclaim deed to the South Carolina Commission of Forestry, later to become Croft State Park. The deed stipulated a restriction on 44 acres for land use only and included recapture provisions.

(3) At document E-5 is an Environmental Protection Agency (EPA) report on a domestic landfill currently in use. The landfill was constructed in 1972 and is located in the south west corner of Croft State Park (see appendix B-5, and sketch at document E-5). A current breakdown of land usage is provided at Table 3-1.

TABLE 3-1 CURRENT LAND OWNER/CONTROLLERS			
Current Owner	Acres	Land Usage	Comments
South Carolina State Park & Recreation Services	7,088.08	Camp Croft State Park	Surface OEW found by SI team. See plates 1, 4 & 5.
Agriculturists	4,936.24	Farming	See documents F-3, L-12 & L-13.
Private Industry	256	Industrial	See Documents F-3, L-12 & L-13.
Homeowners	6,764.14	Residential	See plates 1 & 3, and documents L-12 and L-13.
		(Includes Public Golf Course)	for reference to OEW found at golf course. See plate 1.
TOTAL: 19044.46			

**b. Meteorological Data**

The Spartanburg county climate is considered temperate and rainfall is well distributed through out the year. The prevailing winds are primarily from the southwest but are from the northeast in late summer and early fall. Average wind velocity is about 8 miles per hour. Up until 1968, the average relative humidity per year was approximately 70 percent, with from 1/10 inch of rain (about 76 days/year) up to 1 inch or more (approximately 14 days/year). The highest rainfall recorded is 73.93 inches in 1929. Warm weather generally lasts from some

time in May into September with few breaks in the heat during midsummer. Most summers have 1 or more days when the temperature exceeds 100 degrees Fahrenheit. About 23 percent of the rainfall occurs in fall. Winters are mild and relatively short with nearly 60 days at freezing temperatures or below (appendix B-6 ).

### c. Geology and Soil

(1) The geology of the former Camp Croft area is mostly igneous and metaphoric bedrock with overlying layers of weathered residual bedrock known as saprolite ("red clay"). The median depth of saprolite is between 50 to 60 feet although extreme variances in these depths (from 20 feet to 400+ feet) are on record (print-out of Spartanburg County test well casing depths, appendix B-7). Within Spartanburg county, and specifically the current Croft State Park portion of Camp Croft, are two distinct geologic regions or rock belts: the Inner Piedmont Belt and the Kings Mountain Belt

.....These belts trend NE-SW and bisect the park so that the western portion of the park is located in the Inner Piedmont Belt and the eastern portion is located in the Kings Mountain Belt (see sketch at document E-6). The major portion of the rocks falling in the Inner Piedmont portion of the park can be classified generally as Paleozoic age paragneiss and orthogneiss. More specifically, the paragneiss and orthogneiss of the Inner Piedmont Belt are mainly biotite and granitic gneisses; with sparse amphibole gneiss and minor amounts of amphibolite (Mittwede 1989).

.....The Kings Mountain Shear Zone is a zone of Late Paleozoic deformation separating the Inner Piedmont Belt to the west from the Kings Mountain Belt to the east. This zone is a pronounced discontinuity which exhibits a NE-strike with a steep to moderate SE-dip (Horton 1981). The major portion of the rocks falling within and immediately to the east of the Kings Mountain Shear Zone have been assigned by Mittwede (1989) to the Battleground Formation and included: a) metamorphosed, schistose to gneissic, volcanic and sedimentary rocks; and b) manganiferous mica schist with concordant layers of gondite, assigned by Mittwede (1989) to the Jumping Branch Manganiferous Member of the Battleground Formation. These rocks are generally low- to medium-grade metamorphic rocks, which existed as volcanic and sedimentary rock before they were regionally metamorphosed. (Ferguson Paper/Croft State Park Management Plan, appendix B-8)

(2) Overall, there are thirteen geologic formations in Spartanburg County. These formations are made up of alluvium, fine grained rocks, medium-grained rocks, fine-grained to coarse-grained rocks, and coarse-grained rocks. Alluvium consists of material recently deposited on flood plains. The fine grained rocks are quartite, diabase, taluca quartz monzonite, and sericite schist. The medium-grained rocks are granite, biotite gneiss, and migmatite. The fine-grained to coarse-grained rocks are biotite schist, Yorkville quartz monzonite, and Hornblende schist. The coarse-grained rocks are Hornblende gneiss, coarse-grained granite, and muscovite pegmatite dikes (Appendix B-6).

(3) For an overall breakout of area soil types associated with water drainage patterns see the color coded map at document L-15. Also see the "Geologic Map of the Pacolet 5 Minute Quadrangle" at document L-16 as implemented by the Mittwede document at E-8.

#### **d. Hydrology**

(1) The saprolite unit within the Camp Croft area contains a heterogeneous mixture of sand, silt, and clay with an approximate saturate of hydraulic conductivity of  $10^{-4}$  to  $10^{-7}$  cm/sec. The Hornblende Gneiss Bedrock beneath the saprolite has a permeability estimate greater than  $10^{-3}$  cm/sec. The saprolite and bedrock units are considered to be interconnected and make up the aquifer in this region. (appendix B-5)

(2) Groundwater depth in the south west section of Camp Grant near the current day Camp Croft Landfill is twenty to thirty feet and can be considered typical of groundwater depths through out the former camp. The saprolite in this area has a potential yield of 72,000 gallons per day Vs 201,600 gallons per day for the bedrock unit. (appendices B-5 and B-7)

#### **e. Cultural Resources**

(1) There is ample evidence of early man's activity in and around that portion of the old Camp Croft that is current day Croft State Park. The most evident example is a pre-historic soapstone quarry located in the south-west corner of the park (see document E-7). The Croft Soapstone Quarry was registered with the South Carolina Heritage Trust Program as a Heritage Site on January 20, 1989 (appendix B-9)..

(2) The Croft State Park Management Plan (appendix B-8) includes reference to a number of early "post-settlement" activities and potential historic sites (approximately 55) within the park grounds. Of significance are: the home of John Thomas Sr. where a Revolutionary War skirmish took place (exact location of the Thomas house has not been determined), and eight cemeteries with the oldest headstone dated 1802 (one of the cemeteries is a suspected fake that was set up as a "training area for troops at Camp Croft.").

(3) There are also at least two threatened and endangered plants located on Camp Croft/Croft State Park. The plants are Meadow Sedge (*C. gracilescens*) and Smooth Sunflower (*Helianthus laevigatus*). (see document E-8).

### **4. HISTORICAL ORDNANCE USAGE ON SITE**

#### **a. Chronological Site Summary**

(1) During the spring and summer of 1940, the Japanese navy menaced Southeast Asia and Hitler's armies blitzed their way across France. While Pearl Harbor was still far in the future,

it was obvious to most Americans that the cause of freedom was in grave danger. President Roosevelt ordered most of the National Guard into federal service and signed legislation which authorized the first peace-time draft in American history. As General of the Army, Omar Bradley, later said: "a gigantic mess ensued". All the existing military facilities were swamped by various units trying to mobilize and bring their readiness up to Army standards. Without a major new building program, there would be no place to teach the draftees how to be soldiers and get them ready to join their units (see documents H-1 and K-1).

(2) On November 8, 1940, the War Department announced that one of these new training centers would be located in Spartanburg County, SC. The climate and terrain were perfect for year-round training. The community had supported nearby Camp Wadsworth with enthusiasm during World War I, and had fought unsuccessfully to make it a permanent installation. Long known as the railroad "hub city of the Southeast", Spartanburg also boasted excellent air and bus terminals as well as a pioneering radio station and a strong business community. The city also was the home of James F. Byrnes, one of Washington's most powerful and effective political leaders a fact not lost on the military establishment. (see documents D-4, H-5 and K-1)

(3) Over the next few months, the government spent \$450,000 for the use of about 20,000 acres of land in Spartanburg and Union Counties. The military reservation was named "Camp Croft" in honor of Major General Edward Croft (1874-1938), a South Carolinian who had served with distinction as an officer in World War I and retired as Chief of Infantry. Located on the Southern Railroad about five miles southeast of Spartanburg, the cantonment area surrounding the post headquarters represented a \$10 million investment in structures, roads and supporting utilities. Throughout the winter of 1940-1941, approximately 10,000 construction workers labored on the site. (see documents D-1, D-2, D-4, E-1, E-2, and K-1)

(4) The Camp Croft Infantry Replacement Training Center (IRTC) was officially activated on January 10, 1941, as a part of the Fourth Service Command, with housing for some 20,000 trainees and support personnel. It served the War Department for the next four years-plus as one of the Army's principal IRTCs and as a prisoner of war (POW) camp. The young men who came to Spartanburg and Camp Croft were, for the most part, Yankees from New York, Pennsylvania, and New England. They arrived in groups of 16,000, were introduced to Army discipline, food and friendly drill sergeants, and began the standard 13-week cycle of basic training. They fired M-1 rifles, Browning Automatic Rifles, anti-tank rockets, and infantry mortars on numerous training ranges located to the south of the cantonment area. They ran obstacle and fit-to-fight courses, trained to fight in a chemical environment using the camp's gas chambers and gas obstacle course and even conducted amphibious warfare training using real explosives/explosions to best simulate war. Once they left Camp Croft, they joined units to fight battles all around the world,

e.g. North Africa and Italy; Normandy and the Rhine; and New Guinea and the Philippines (see documents D-1, D-3, D-4, E-3, F-1, H-2, H-3, H-4, H-6, H-7, and K-1).

(5) Having decided not to convert Camp Croft into a permanent military installation, the War Department agreed early in 1945 to sell the cantonment area, the sewer and water plants, and a good portion of the training center to the Spartanburg County Foundation (SCF) for \$1 million. The installation was declared surplus to the Army's needs in November 1946, and excess to the War Assets Administration in 1947 (see documents E-4, F-3, and K-1).

(6) Accountability for the 19,044.46 acres at Camp Croft was transferred to the War Assets Administration on 19 April 1947 with final audit due 22 September 1949 and conversion of the post to peacetime use was well underway. The land where troops once trained to fight for freedom is now used for residential streets, homes and churches, industrial and commercial businesses, and recreation (Croft State Park and the Spartanburg Little Theater). (see documents K-1 and L-13)

#### **b. Ordnance Related Records Review.**

(1) Research efforts for the former Camp Croft began with a thorough review of all reports, historical documents and reference material gathered during the ASR historical document search. During this review, an effort was made to focus on areas of potential OEW contamination as described in the OEW Project Summary Sheet (see document F-6, D-3, E-1 and K-1). These areas included the gas chambers and gas obstacle course, the grenade court, an ammunition storage location, and no fewer than eleven live ammunition training ranges used for small arms ammunition, anti-tank rockets, anti-aircraft artillery, and 60mm and 81mm infantry mortars.

(2) A relatively large collection of documents, including drawings, maps, technical ordnance data, real estate documentation, correspondence, journals, newspaper articles and various other records appropriate to Camp Croft, had been located. The information from these documents was invaluable in terms of assessing potential and actual OEW at the former Camp Croft. The following information is extracted from these documents which are enclosed as appendices to this ASR. This information indicates the type and extent of activities conducted at the Camp Croft IRTC between 10 February 1941 and 14 August 1945, the conclusion of World War II, and gradual cessation of infantry training cycles at the camp.

(a) Texts at documents D-1 through D-4 address Spartanburg and Union counties in South Carolina prior to, during, and after the existence of Camp Croft, one of the War Department's principal infantry replacement training centers. Document D-1, History of Camp Croft, states that Camp Croft was "one of the most modern of infantry replacement centers in the nation", "crackling rifles and machine guns disturb nature's

quietude" and "the acquisition of the range, nearly 16,000 acres of Piedmont farmlands, also majored in the developments of April (1941)". Document D-2 reads, in part, "by July 31, 1945, 199,839 men had been ordered into Camp Croft for training in all phases of infantry combat". Document D-3 relays that "most of what is now Croft State Park was once the down range or impact areas for the firing ranges at Camp Croft" and "records indicate there were ranges at Camp Croft for rifle, pistol, machine gun, mortar (60mm and 81mm), as well as anti-aircraft and anti-tank ranges". And finally, document D-4 notes that "between eighteen and twenty thousand men pass their training period at Camp Croft every three months".

(b) Document E-1 indicates that Camp Croft included 10,392 acres of range impact area and what types of munitions were fired on the ranges. See paragraph 4.b.(1) above for types.

(c) A letter from the office of the Chief of Engineers, document F-7, states that "portions of tracts 70, 71, and 72, it has been found require restriction to surface use only". Document F-8, on the other hand, certifies all ranges have been cleared of dangerous and/or explosive materials.

(d). Document F-9 notes that during an interview with Mr. Ray Hayes, then Superintendent at Croft State Park, he relayed one incident where Boy Scouts had unearthed two cases of 50mm (caliber) machine gun ammunition. He also told of finding several hand grenades scattered about a wooded area near an old foundation. Mr. Hayes also indicated that on several occasions, personnel from Fort Jackson "deactivated or exploded" ordnance that was found on Park property. The author of this document, stated "Camp Croft does not appear to have any problems related to former DOD activities with the possible exception of unexploded ordnance". In document F-10, a former maintenance engineer at Camp Croft states "they (Fort Jackson) were called on occasion to come blow up mortars and other live ammunition discovered after the camp's closing"; this document also mentions that ordnance may have been disposed of by dumping in water wells.

(e). In a conversation with the 48th EOD, Fort Jackson, document F-11, it is stated that "most of the ordnance recovered by the 48th EOD was 60-80mm (81mm) practice mortars (just steel-no charge); some were practice mortars with fuzes and spotting charges (could cause harm if exploded, but would not throw shrapnel over a wide area); and a few were high explosive (very dangerous). Based on the ordnance commonly used at similar training areas, there may also be Stokes mortars". In Conversation Record, document F-12, an A & E contractor was calling the Corps of Engineers looking for the location of the water wells mentioned in subparagraph (d) above.

(f). Document F-13 is a memorandum from the USACE, Savannah District enclosing a map detailing areas of former Camp Croft restricted to surface use only and locations where explosives were found. The "Camp Croft Calls Related to Ordnance" document, F-15, contains a number of conversation

records. A member of the Spartanburg County Sheriff Bomb Disposal indicates "there is a lot of ordnance out there, this confirms the practice mortars and grenades and live mortars and grenades". The Park Superintendent refers to a "grenade last winter and machine gun shells a few months ago, along with a mortar shell found by a person with a metal detector". An employee of the South Carolina Narcotics Division, formerly of the 48th EOD, said "they removed 82mm (81mm) practice mortars, practice grenades, and 2.36 inch and 3.5 inch rockets. Very little high explosive material". He says the practice mortars pose little hazard due to 50 years. of deterioration.

(g). The sketch at document F-16, drawn by a Corps of Engineers, Charleston District employee, depicts a large rifle range, (see photographs J-17 through J-24), where a "shell" had recently been found. The South Carolina Division of Parks Memorandum at document F-18 mentions a request for the ordnance disposal unit at Fort Jackson to do a limited survey in the area (about 100 yards in on Henningston Road, approaching from the east) where a live mortar round had been recently found. (see documents F-19 through F-21, and I-5)

(h) The Camp Croft 50th Anniversary Celebration Brochure, document K-1, contains photographs showing troops during their 13-week training cycle using live ammunition and explosives to simulate a war environment.

(i) Documents L-3 and L-14 are maps that regard the former Camp Croft Infantry Replacement Training Center. These maps depict the locations of the camp gas chambers and gas obstacle course, grenade court, and the various ammunition firing ranges. The latter shows those areas that are restricted to surface use only and, also, areas where explosives have been located.

### **c. Interviews with Site Related Personnel.**

(1) The Site Inspection (SI) team's primary point-of-contact (POC), during the SI of the former Camp Croft IRTC, was the newly assigned Croft State Park Superintendent. The POC's assistance was invaluable not only in the team's conduct of the SI, but also in the preparation of this ASR. During the interview of this gentleman on 24 March 1993 (document I-3), he relayed to the team an incident of two mortar rounds being located on the park near the swimming pool in the vicinity of Lake Craig. He also gave the team mapping of Croft State Park and authorized access to all parts of the 7,000 acre park, providing combinations to gate locks.

(2) The most knowledgeable persons regarding the former Camp Croft IRTC were interviewed on 25 March 1993 (document I-1). These gentlemen, a military retiree and an employee of the Spartanburg Fire Department, relayed an incident of a grenade having been located near where the sewer line crosses Highview Road just to the south of the former Camp Croft cantonment area. They verified on mapping, present day locations of the former Camp Croft grenade court, various firing ranges, gas chambers,

bayonet court, ammunition storage area, parade grounds, and other points of interest in the cantonment area. The younger of the two gentlemen indicated that, as a child, he had dug up, in what is now his backyard, what he described as "mustard gas packets". His home is located in the former camp cantonment area. After the interview concluded, they accompanied the team to an area in the northwest part of the park, not far from the intersection of Dairy Ridge Road and Croft State Park Road, where they said much OEW had been located. One incident, in particular, that they relayed to the team had eighty grenades being located in this area, stacked by a tree (see document F-15 and plate 7).

(3) The President of the Spartanburg Chamber of Commerce (see document I-2), provided the team with the 50th Anniversary Brochure for the former Camp Croft. Document K-1, contains a wealth of historical photographs. He had little other information to provide the team; he did, however, direct the team to other interviewees.

(4) During an interview with a Croft State Park ranger on 25 March 1993 (document I-4), it was pointed out to the team that he has been able to walk through the woods of the park and located ordnance at will. Although he did not have time to accompany the SI team, he did point out on a map the area where he had located the most ordnance. This area was in the northwest part of the park, not far to the south of the intersection of Dairy Ridge Road and Croft State Park Road.

(5) During a telephone conversation 28 July 1993 with the USACE, Charleston District representative for this ASR (document I-5), it was verified that mortar rounds had been recently discovered 100 yards in on Henningston Road, approaching from the east and, also, near the rifle range target pit in the Whitestone Area of the former Camp Croft, (see documents F-16, F-19 through F-21 and J-17 through J-24).

## 5. REAL ESTATE.

### a. **Confirmed Formerly Used Defense Sites**

(1). Land usage and ownership of the former Camp Croft military reservation by the Department of Defense (DOD) has been confirmed and is summarized in COE document F-3, Findings and Determination of Eligibility (FDE). The base consisted of 19,044.46 acres acquired in late 1940 (see plate 1). Camp Croft was acquired by DOD for use as one of the Army's principal Infantry replacement training centers.

(2). The base was deactivated in 1947 and declared excess to the War Assets Administration's needs. The process of transfer of properties to current owners or jurisdictions began the same year. (see table 3-1 and document L-13).



## b. Potential Formerly Used Defense Sites

All acreage for this base are covered in the "Finding and Determination of Eligibility" report dated 25 November, 1991 (see document F-3). No other acreage with potential ordnance usage was discovered during the site investigation or literature search for this facility.

## 6. SITE INSPECTION

### a. General Procedures and Safety.

(1) During the period of 24-26 March 1993, members of the Site Inspection (SI) team assessed the former Camp Croft Infantry Replacement Training Center (IRTC) located near Spartanburg, South Carolina, (see documents L-1 and L-2 and plates 1 thru 6). The land which once hosted Camp Croft is, today, residential areas, commercial and industrial business districts, and Croft State Park. The primary task of the SI team was to assess the former IRTC for OEW presence and potential presence, concentrating on the grenade court, gas chambers and gas obstacle course area, the ammunition storage area and the various ammunition firing ranges which once supported this site. The site inspection was limited to non-intrusive methods i.e., subsurface sampling was not authorized or performed.

(2) Real Estate rights-of-entry were not obtained due to the willingness of Croft State Park employees and local residents to accommodate the SI team. Control of the former site therefore remained with these personnel.

(3) A site safety plan for this former site, (see appendix B-4), was developed and utilized by the SI team to assure safety from injury during the site inspection. A briefing prior to the inspection was conducted at Croft State Park which stressed that OEW should only be handled by military EOD personnel. Continuing safety instructions were given to accompanying personnel during the inspection.

(4) Prior to the site visit, a thorough review was conducted of all reports, historical documents, texts, and technical ordnance reference materials located by CENCR and USATCES during the ASR historical records search. The review was made, in part, to ensure awareness of potential ordnance types and hazards that may have been encountered during the SI.

(5) The visit began at the office of the newly assigned Croft State Park Superintendent, Mr. Jerry Perry, with an exchange of information between Mr. Perry and SI team members Messrs. Jodi Bausman, CENCR and Mike Harper, USATCES. During this initial exchange of information, it was learned that two mortar rounds had recently been located in the park near the swimming pool in the vicinity of Lake Craig (see document I-3, and plate 4). Mr. Perry gave the team a map of the 7,000 acre park and authorized the team access to all areas of the park, providing the team combinations to all gate locks. The team formulated and implemented a plan of action for the site

inspection, and the assessment of the former IRTC began. It should be stressed, again, that intrusive sampling methods were not used during this site inspection.

**c. Training Range Impact Area.**

(1) The OEW assessment of the former Camp Croft IRTC began at the west side of Croft State Park (see photo J-1), with the SI team entering near the intersection of Henningston Road and Croft State Park Road (see plate 5). The team walked the lands adjacent to Henningston Road for a distance that in W.W.II would have encompassed parts of the downrange impact areas of former IRTC ammunition training ranges 7 through 11 (see plate 7). This area of present-day Croft State Park is littered with OEW that would have been generated during small arms ammunition and mortar training conducted by infantry troops during the war. Ordnance waste located included .30 caliber bullets and Trench Mortar Weapon, 60mm and 81mm, Fin Assemblies (cartridge container and blades). (see photos J-2 through J-6, documents L-3, L-4, and plates 2 and 7).

(2) The team proceeded, by way of Dairy Ridge Road, see Document J-7, toward the east side of Croft State Park. Enroute, on the north side of Dairy Ridge Road, the team located the former IRTC ammunition storage area (photos J-8, J-9, and plate 5). Today, the storage area is overgrown with kudzu but still being used by the National Guard. Farther east on Dairy Ridge Road stands an old range tower (see photos J-10 through J-12), that would have provided control and safety functions to the IRTC training ranges. The tower stands just to the north of former ranges 4 and 5 (plate 3). Photo J-13 is a view downrange of what was previously range 5. The team then approached Croft State Park from the east on Henningston Road. The land adjacent to this road, which would have included property from the east boundary of the former camp westward through ammunition training ranges 3 through 7, was walked. Prior to entering Croft State Park and before reaching lands that would have been the former camp impact areas for ranges 3 through 7, a Body and Fuze, Shell, Illuminating, M83 (60 mm Trench Mortar Weapon) was located, (see photo J-14). Continuing west on Henningston Road and onto land that would have been the impact areas for ammunition training ranges 3 through 7, the team noted much OEW e.g., Trench Mortar Fin Assemblies; Links for 20mm Cartridges; and Fuze, Percussion, D.A., No. 253 Mk. I (see photos J-15 through J-18, documents L-3, L-4, and plates 2 and 5).

(3) The team continued its inspection of the impact areas, entering the former site, again, from the east, but on White Stone Road. The team located a large target pit which was approximately one-half mile in width, see photos J-19 through J-26 and pages 40-41 of K-1. This structure served as the target display area for the IRTC rifle and automatic rifle 200, 300, and 500 yard training range, (see documents L-3, L-4, and plate 6).

(4) The inspection continued deeper into the former impact area, approaching, again, from the former camp west boundary on a road which originates in Whitestone, SC. After

entering into Croft State Park and through a locked gate, (see photos J-27 and J-28), the team reached Lake Edwin W. Johnson, (see photo J-29). A red clay roadway leading away from the lake was found to be heavily contaminated with SAA bullets, .30 Caliber, (see photos J-30 thru J-34). This road and adjacent property, which would have included impact areas for former ranges 3, 6 and 7, were inspected for a distance of approximately three-quarter of a mile (see documents L-3, L-4 and plate 4).

(5) The SI moved to an area of the park south of the intersection of Dairy Ridge Road and Croft State Park Road. The team had been told that considerable amounts of OEW, i.e. "mortars, grenades and illumination rounds", had been located in this vicinity through the years (see documents I-1, I-4, and plate 5). This area would have served the IRTC as ranges 9 through 11. The SI team located the remnants of a moving target, (see photos J-35 through J-39). A military retiree who accompanied the team in this area, (see document I-1), located a Signal, Illumination, Ground: Smoke, M60 series, (see Document J-40 and plate 5). This round, however, would not have been of the W.W.II era.

(6) The team traveled to an area just north of Dairy Ridge Road and the former training ranges, where a hand grenade had recently been located, (see Document I-1). The grenade was found near the intersection of Highview Road and the sewer line (see photo J-41 and plate 3).

#### **c. Gas Chambers and Gas Obstacle Course Area.**

(1) The team assessed an area near the Kohler, Inc. administrative offices, (see photos J-42 through J-44). The IRTC gas chambers and obstacle course were located on land to the east of the Kohler parking lot (see pages 29-30, documents K-1, document L-3, L-4, and plate 3). These structures have since been removed and no chemical ordnance or other evidence of past chemical training were found.

#### **d. Cantonment Area.**

(1) A military retiree and his son accompanied the SI team through the present-day Camp Croft residential area (see document I-1, and plate 3). During W.W.II, this area was the Camp Croft cantonment area. This tour included discussions regarding the history of the former camp and identification of many of the remaining Camp Croft-era structures (see photos J-45 through J-47, page 35 of K-1, L-5, and plates 2 and 3),

(2) During these discussions, the son who lives in this residential area, recalled unearthing in his backyard what he described as 6 or 7 "mustard gas packets". The packets were green and rectangular in shape, about 3 or 4 inches in height by 5 or 6 inches in width, and had a "flip top". The packet contained two tubes. The larger tube was green and contained a yellow ointment. He was unsure of the color of the smaller tube, but it contained a clear ointment. He also remembered the packets containing gauze and directions.

(3) The location where these packets were found is approximately 100 to 150 feet off of Pershing Street, between Lumis Avenue and Ranson Avenue, (see documents L-5 and plate 3)

**e. Grenade Court.**

The final inspection conducted by the SI team was of the former IRTC grenade court. This court was in an area to the southeast of the cantonment area, (see photo J-48, documents K-1 (page 39), L-3, L-4, and plate 3). This area, during the SI, was being graded for future construction. There was no evidence of OEW located at this site.

**7. EVALUATION OF ORDNANCE PRESENCE**

**a. General Procedures**

(1) Each subsite was evaluated to determine confirmed, or potential, ordnance presence or the absence of OEW contamination. Confirmed ordnance contamination is based on verifiable historical evidence or direct witness of ordnance items. Verifiable historical record evidence consists of ordnance items located on site and documented by local bomb squads, Army Explosive Ordnance Demolition Teams, newspaper articles, correspondence, current findings, etc. Direct witness of ordnance items consists of the inspection team verifying ordnance items by visual inspection. Additional field data is not needed to identify a confirmed subsite.

(2) Potential ordnance contamination is based on a lack of confirmed ordnance. Potential ordnance contamination is inferred from records or indirect witness. Inference from historical records would include data or knowledge of common practices in production, storage, usage, or disposal, at that time, which could have allowed present day ordnance contamination. Potential ordnance contamination could also be based on indirect witness or from present day site features. Additional field data is needed to confirm potential ordnance subsites.

(3) Uncontaminated ordnance subsites are based on a lack of confirmed or potential ordnance evidence. This occurs when historical records evidence and present day site inspections do not indicate confirmed or potential ordnance contamination. In this case, there is no reasonable evidence, either direct or inferred, to suggest present day ordnance contamination. Additional field data is not needed to assess uncontaminated ordnance subsites.

**b. Training Range Impact Area.**

(1) During the literature search for Camp Croft IRTC, original site documentation, drawings, photographs, and newspaper articles verified that the camp, during World War II, was used as an infantry training facility. Approximately one-quarter of a million soldiers were trained there in the use of rifle, grenade,

mortar, anti-aircraft, and anti-tank ammunition on no fewer than eleven live ammunition training ranges. Additionally, much historical recorded evidence was located to document and confirm present-day ordnance on the site (see paragraph 4.b. of this ASR).

(2) The SI conducted by CENCR and USATCES ammunition specialists included personal interviews which further confirmed present-day ordnance on the ranges at the IRTC (see paragraphs 4.c. and 6.b. of this ASR). Through direct witness of OEW and personal interviews, between 24-26 March 1993, the team substantiated the presence of such ammunition items as SAA, grenades, mortars (60mm and 81mm) and 20mm anti-aircraft cartridges on the training ranges.

(3) Considering the documented mission of this IRTC and the, then, acceptable disposal method of burial, the potential for large quantities of the ammunition and explosives as listed in Table 8-1, exists at the former Camp Croft training ranges and proximate support areas.

#### **c. Gas Chambers and Gas Obstacle Course Area.**

(1) During the literature search conducted of this site, drawings and photographs verified the location and use of this area. The chambers and obstacle course provided a realistic chemical warfare environment in which to train soldiers. No historical recorded evidence was located to document and confirm the presence of chemical ordnance since site closure.

(2) The SI of this area did not produce evidence of any chemical ordnance or other OEW, see paragraph 6.c. of this ASR. Based on the nature of the camp's mission at this location, however, the potential for chemical ordnance or chemical contamination of the soil in this area does exist.

#### **d. Cantonment Area.**

(1) The literature search of this site verified the location and use of this area. Not unlike any other installation cantonment area, it was the area in which the troops were housed, fed, entertained, drilled and provided health care. The search did not confirm present-day ordnance in this area.

(2) The SI did not find evidence of ordnance in this area since site closure. The team, however, during an interview, was told of the unearthing of "mustard gas packets" in this area, see document I-1 and paragraph 6.d. this ASR. As described by the interviewee, these packets would not have been Chemical Agent Identification Sets (CAIS) containing chemical agent, as defined in document D-8, but rather packets of ointment similar to that described at document D-9, Vesicant Agent Protective Ointment: M5 or possibly just first-aid kits issued by the camp hospital.

(3) This site, however, was an infantry replacement training center, so the possibility exists that munitions could be buried almost anywhere in the general cantonment vicinity.

e. **Grenade Court.**

(1) During the literature search conducted of this site, drawings and photographs verified the location and use of a grenade court for the training of infantrymen. No historical recorded evidence, however, was located to document and confirm present-day ordnance at the court.

(2) The SI of the grenade court location found no evidence of grenades or other ordnance waste, see paragraph 6.e. this ASR.

(3) Considering the IRTC training mission conducted at this location, however, the potential for present-day ordnance exists at the former Camp Croft grenade court.

8. TECHNICAL DATA OF ORDNANCE AND EXPLOSIVES

Table 8-1 provides a listing of components of ammunition verified on location at the former Camp Croft Infantry Replacement Training Center (IRTC) since its closure, or ordnance known to have been used at the IRTC. The table also includes a summary of the chemical composition of the fillers for this ordnance. Data in the table is based on reviews of historical documentation and specifications stated at documents D-5 through D-7. Exact models/types have been included as documentation has permitted.

**TABLE 8-1**  
**ORDNANCE ITEMS VISUALLY VERIFIED ON SITE OR SUSPECTED OF BEING ON SITE 1/**

NAME	MODEL/TYPE	FILLER/WEIGHT	SYNONYM(S)	CHEMICAL FORMULA
Small Arms Ammo .30 Cal <u>1/</u>	M2 Ball, M2 AP M1, M10 Tracer M1, Incendiary	Gilding metal, Lead, Tracer composition, Incendiary Composition, Nitrocellulose 13% Nitrogen (Blended with guncotton) Nitroglycerin	Nitrocotton; Pyroxylin Cellulose Nitrate	UNKNOWN UNKNOWN N <sub>2</sub>
Small Arms Ammo .50 Cal <u>1/</u>	M2 Ball, M2 AP; M1, M10, M17, & M21 Tracer M1 & M23 Incend	Gilding Metal, Lead, Tracer Composition, Incendiary Composition Nitrocellulose, Nitroglycerin	See above	UNKNOWN
Cartridge, H.E.-I 20mm <u>1/</u> Fuze, percussion Primer, percussion	MK I D.A., No.253 MK I /A/ M36	HE-Incendiary/175.2 gr UNKNOWN Primer Mixture/2.1 gr Mercury Fulminate Potassium Chlorate Antimony Sulfide		UNKNOWN Hg(ONC) <sub>2</sub> KClO <sub>3</sub> Sb <sub>2</sub> S <sub>3</sub>
Propelling Charge		FNH pwdr, Type II/0.07# Nitrocellulose Dinitrotoluene Dibutylphthalate Diphenylamine	See above DNT gelling agent stabilizer DPA	See above C <sub>6</sub> H <sub>2</sub> CH <sub>3</sub> (NO <sub>2</sub> ) <sub>2</sub> C <sub>6</sub> H <sub>4</sub> (CO <sub>2</sub> C <sub>4</sub> H <sub>9</sub> ) <sub>2</sub> C <sub>6</sub> H <sub>5</sub> ) <sub>2</sub> NH

1/ Ordnance items verified on site by the SI Team or eyewitness accounts.

**TABLE 8-1**  
**ORDNANCE ITEMS VISUALLY VERIFIED ON SITE OR SUSPECTED OF BEING ON SITE 1/**

NAME	MODEL/TYPE	FILLER/WEIGHT	SYNONYM(S)	CHEMICAL FORMULA
Cartridge, AP-T 20mm	M75			
Primer, percuss.	M36	See above		
Propelling Charge		FNH pwdr, Type II/0.07 #	See above	
Tracer		Tracer mixture		UNKNOWN
Grenade, Hand, Fragmentation <u>1/</u>	MK II	Bursting Charge  (E.C. Blank Powder) Nitrocellulose/.59oz Potassium Nitrate/.06oz Barium Nitrate/.06oz		See above KNO <sub>3</sub> Ba(NO <sub>3</sub> ) <sub>2</sub>
Fuze	M10			
Primer	MK V	Primer Mixture/0.4 gr		
Delay - Time Fuse		Black Powder train/2 gr		
Detonator		Loose Black Powder/7 gr 74% Potassium Nitrate	Saltpeter; Niter	KNO <sub>3</sub>
		11% Sulfur 16% Charcoal		S C
Grenade, Hand, Offensive	MK IIIA2	Bursting Charge .5# Pressed TNT	2,4,6,Trinitrotoluene	C <sub>6</sub> H <sub>2</sub> CH <sub>3</sub> (NO <sub>2</sub> ) <sub>3</sub>
Fuze	M6A2	UNKNOWN		
Primer		UNKNOWN		
Delay		UNKNOWN		
Detonator		UNKNOWN		
Grenade, Hand, CN Tear	M7	CN	Chloroacetophenone	C <sub>6</sub> H <sub>5</sub> CO-CH <sub>2</sub> Cl
Fuze	None	Similiar to M10 above		
Igniter vice Detonator				

1/ Ordnance items verified on site by the SI Team or eyewitness accounts.



**TABLE 8-1**  
**ORDNANCE ITEMS VISUALLY VERIFIED ON SITE OR SUSPECTED OF BEING ON SITE 1/**

NAME	MODEL/TYPE	FILLER/WEIGHT	SYNONYM(S)	CHEMICAL FORMULA
		Grenade, HC Smoke Hexachlorethane-Zinc	M8	HC  Zn+C <sub>2</sub> Cl <sub>6</sub>
Fuze	None	See above		
Grenade, TH Incendiary Fuze	None	Thermite	Iron Oxide & Aluminum	2Al-3FeO
Grenade, Colored Smoke Fuze	M16	UNKNOWN		
	None	See above		
Grenade, Colored Smoke Fuze	M18	UNKNOWN		
	None	See above		
Grenade, Red Smoke Fuze	AN-M3	UNKNOWN		
	None	See above		
Grenade, White Phosphorus Smoke Detonating Cord	M15	White Phosphorus		P
	None	PETN	Pentaerythritetetrani- trite; TEN Nitropenta; 1,3-Propanediol; 2,2-bis[(Nitrooxy)Methyl]	C <sub>5</sub> H <sub>8</sub> O <sub>4</sub> (NO <sub>2</sub> ) <sub>4</sub>
Grenade, Rifle, WP Smoke Detonator	M19	White Phosphorus		P
	None	UNKNOWN		
Grenade, Rifle, Colored Smoke Detonator	M22	UNKNOWN		
	None	UNKNOWN		

1/ Ordnance items verified on site by the SI Team or eyewitness accounts.

**TABLE 8-1**  
**ORDNANCE ITEMS VISUALLY VERIFIED ON SITE OR SUSPECTED OF BEING ON SITE 1/**

NAME	MODEL/TYPE	FILLER/WEIGHT	SYNONYM(S)	CHEMICAL FORMULA
Grenade, Rifle, Antitank <u>1/</u>	M9A1	50/50 Pentolite 50% TNT 50% PETN		See above See above
Fuze	None	Priming Mixture Lead Azide Tetryl	Azide Trinitrophenyl- methylnitramine	PbN <sub>6</sub>
Grenade, Rifle, HC	UNKNOWN	HC	Hexachlorethane-Zinc	(NO <sub>2</sub> ) <sub>3</sub> C <sub>6</sub> H <sub>2</sub> N(NO <sub>2</sub> )CH <sub>3</sub> Zn+C <sub>2</sub> Cl <sub>6</sub>
Grenade, Rifle, Practice <u>1/</u>	M11A3	INERT		
Shell, H.E. 60mm	M49A2	TNT/0.34#		See above
Fuze, P.D. Detonator	M52	Priming Mixture	Mercury Fulminate	Hg (ONC) <sub>2</sub>
Booster		Lead Azide Tetryl	See above See above	
Ignition Cartridge	M5A1	DB powder/40 gr	Nitroglycerine Nitrocellulose	CH <sub>2</sub> NO <sub>3</sub> CHNO <sub>3</sub> CH <sub>2</sub> NO <sub>3</sub> N <sub>2</sub>
Percussion Primer	M32			
Propellant Increm.	M3	DB powder/140 gr	Nitroglycerine Nitrocellulose	See above See above
Shell, Practice 60mm <u>1/</u>	M50A2	Black Powder/0.05#		See above
Fuze, P.D.	M52	See above		
Ignition Cartridge	M5A1	See above		
Percussion Primer	M32	See above		

1/ Ordnance items verified on site by the SI Team or eyewitness accounts.

**TABLE 8-1**  
**ORDNANCE ITEMS VISUALLY VERIFIED ON SITE OR SUSPECTED OF BEING ON SITE 1/**

NAME	MODEL/TYPE	FILLER/WEIGHT	SYNONYM(S)	CHEMICAL FORMULA
Shell, Smoke, WP 60mm	M302	White Phosphorus		
Fuze, P.D.	M82	UNKNOWN		
Ignition Cartridge	UNKNOWN			
Percussion Primer	UNKNOWN			
Propellant Increm.	UNKNOWN			
Shell, Illuminating 60mm <u>1/</u>	M83	Illuminant Charge		
		52.1% Barium Nitrate		See above
		10.4% Sodium Nitrate		NaNO <sub>3</sub>
		26.0% Aluminum		Al
		5.2% Sodium Oxalate		Na <sub>2</sub> C <sub>2</sub> O <sub>4</sub>
		4.1% Sulfur		S
		1.1% Castor Oil		
		1.1% Linseed Oil		
		Quick Match		UNKNOWN
		First Fire Charge		
		Pellet - 25% black powder/0.740z		See above
		Priming Charge		
		Black powder/0.055oz		See above
Ignition Cartridge	M5A1	See above		
Percussion Primer	M32	See above		
Propellant Increm.	M4	DB powder/112 gr	Nitroglycerine Nitrocellulose	N <sub>2</sub>
Shell, Training 60mm <u>1/</u>	M69	INERT		
Ignition Cartridge	M4	DB powder/47 gr	Nitroglycerine Nitrocellulose	N <sub>2</sub>

1/ Ordnance items verified on site by the SI Team or eyewitness accounts.

**TABLE 8-1**  
**ORDNANCE ITEMS VISUALLY VERIFIED ON SITE OR SUSPECTED OF BEING ON SITE 1/**

NAME	MODEL/TYPE	FILLER/WEIGHT	SYNONYM(S)	CHEMICAL FORMULA
Shell, Training 81mm	M68	INERT		
Ignition Cartridge	M3	DB powder/120 gr	Nitroglycerine Nitrocellulose	N <sub>2</sub>
Shell, H.E. 81mm	M43A1	TNT/1.22#	2,4,6,Trinitrotoluene	C <sub>6</sub> H <sub>2</sub> CH <sub>3</sub> (NO <sub>2</sub> ) <sub>3</sub>
Fuze, P.D. Detonator	M52	Priming Mixture	Mercury Fulminate	Hg(ONC) <sub>2</sub>
Booster		Lead Azide	See above	
Ignition Cartridge	M6	Tetryl	See above	
Percussion Primer	M33	DB powder/120 gr	Nitroglycerine Nitrocellulose	N <sub>2</sub>
Propellant Increm.	M1	DB powder/700 gr	Nitroglycerine Nitrocellulose	N <sub>2</sub>
Shell, H.E. 81mm	M56	TNT/4.31#	2,4,6,Trinitrotoluene	C <sub>6</sub> H <sub>2</sub> CH <sub>3</sub> (NO <sub>2</sub> ) <sub>3</sub>
Fuze, P.D. Primer	M53			
Delay Pellet		Black Powder		See above
Relay		Lead Azide		See above
Detonator		Tetryl		See above
Lead Charge		Lead Azide		See above
Booster		Tetryl		See above
Ignition Cartridge	M3 (old)	See above		See above
	M6 (new)	See above		
Percussion Primer	M34			
Propellant Increm.	M2	DB powder/820 gr	Nitroglycerine Nitrocellulose	N <sub>2</sub>

1/ Ordnance items verified on site by the SI Team or eyewitness accounts.

**TABLE 8-1**  
**ORDNANCE ITEMS VISUALLY VERIFIED ON SITE OR SUSPECTED OF BEING ON SITE 1/**

NAME	MODEL/TYPE	FILLER/WEIGHT	SYNONYM(S)	CHEMICAL FORMULA
Shell, H.E. 81mm	M56	TNT/4.31#	Trinitrophenyl- methylnitramine	$(NO_2)_3C_6H_2N(NO)_2CH_3$
Fuze, TSQ	M77	UNKNOWN		
Ignition Cartridge	M3 (old) M6 (new)	See above See above		
Percussion Primer	M34			
Propellant Increm.	M2	DB powder/820 gr	Nitroglycerine Nitrocellulose	N <sub>2</sub>
Shell, WP Smoke 81mm	M57	White Phosphorus/4.04#		see above
Fuze, P.D.	M52	See above		
Ignition Cartridge	M3 (old) M6 (new)	See above See above		
Percussion Primer	M34			
Propellant Increm.	M2	DB powder/820 gr	Nitroglycerine Nitrocellulose	N <sub>2</sub>
Rocket, HEAT 2.36-inch Fuze	M6, M6A1, M6A3	0.5# 50/50 Pentolite		See above
Detonator	None	Priming Mixture Lead Azide Tetryl		See above See above See above
Booster		Tetryl		See above
Propellant		Sticks of DB powder		See above
Squib		Black powder		See above
Rocket, HEAT 2.36-inch Fuze	M6A3D	50/50 Pentolite/0.5#		See above
Propellant	None	See above M7 (T4) powder		

1/ Ordnance items verified on site by the SI Team or eyewitness accounts.

**TABLE 8-1**  
**ORDNANCE ITEMS VISUALLY VERIFIED ON SITE OR SUSPECTED OF BEING ON SITE 1/**

NAME	MODEL/TYPE	FILLER/WEIGHT	SYNONYM(S)	CHEMICAL FORMULA
Rocket, HEAT 2.36-inch Fuze Propellant	M6A3F  None    See above	50/50 Pentolite/0.5#  M7 (T4) powder		See above
Rocket, HEAT 2.36-inch Fuze, BD Propellant	M6A4  M400	50/50 Pentolite/0.5#  M7 (T4) powder		See above
Rocket, HEAT 2.36-inch Fuze, BD Propellant	M6A5  M401	50/50 Pentolite/0.5#  M7 (T4) powder		See above
Rocket, Practice 2.36-inch Propellant Squib	M7, M7A1, M7A3, M7A4	INERT  Sticks of DB powder Black powder		See above See above
Rocket, Practice 2.36-inch Propellant	M7A5	INERT  T1E1 salted powder		
Rocket, Practice 2.36-inch Propellant	M7A6    INERT	M7 (T4) powder		

1/ Ordnance items verified on site by the SI Team or eyewitness accounts.

**TABLE 8-1**  
**ORDNANCE ITEMS VISUALLY VERIFIED ON SITE OR SUSPECTED OF BEING ON SITE 1/**

NAME	MODEL/TYPE	FILLER/WEIGHT	SYNONYM(S)	CHEMICAL FORMULA
Rocket, WP Smoke 2.36-inch	M10	White Phosphorus/0.9#		See above
Fuze	None			
Detonator		Priming Mixture		See above
		Lead Azide		See above
		Tetryl		See above
Detonator-Burster		UNKNOWN		
Propellant		Sticks of DB powder		See above
Squib		Black powder		See above
Rocket, WP Smoke 2.36-inch	M10A3	White Phosphorus/0.9#		See above
Fuze, BD	M401			
Propellant		M7 powder		
Rocket, HC Smoke 2.36-inch	T27E1	HC/1#		See above
Fuze	None			
Detonator		Priming Mixture		See above
		Lead Azide		See above
		Tetryl		See above
Igniter		UNKNOWN		
Propellant		Sticks of DB powder		See above
Squib		Black powder	See above	
Rocket, Incendiary 2.36-inch	T31	Thermate/1.1#		See above
Fuze	None			
Detonator		Priming Mixture		See above
		Lead Azide		See above
		Tetryl		See above
Igniter		UNKNOWN		
Propellant		Sticks of DB powder		See above
Squib		Black powder		See above

1/ Ordnance items verified on site by the SI Team or eyewitness accounts.

9. EVALUATION OF OTHER SITE HAZARDS

a. **HTRW**

There are currently two HTRW projects identified for the former Camp Croft area. Project I04SC00601 relates to potential containerized (metal drums) HTRW dumped in wells and Project I04SC00602 for possible HTRW contamination from any drum leakage, or from materiel that might have been deposited in landfills or trenches where excess items were buried during closure of the site. Both projects are being performed by CESAC (see documents E4, F4 and F5).

b. **BD/DR**

There are no current BD/DR projects identified for this site (see document F5) nor were any additional areas of concern noted for this category outside the boundaries of this project site during the SI.



ORDNANCE AND EXPLOSIVE WASTE  
ARCHIVES SEARCH REPORT  
FOR  
FORMER CAMP CROFT ARMY TRAINING FACILITY  
SPARTANBURG, SOUTH CAROLINA  
PROJECT NUMBER I04SC001603

APPENDIX A

ACKNOWLEDGMENTS OF ORGANIZATIONS/PERSONNEL

## APPENDIX A

ACKNOWLEDGMENTS OF ORGANIZATIONS/PERSONNEL			
Organization	Name	Telephone	Nature of Support
191 Pershing St. Spartanburg, SC 29302	Mr. George Mullinax Military retiree	(803) 582-5831	Interview tour of former Camp Croft cantonment area and firing ranges
191 Pershing St. Spartanburg, SC 29302	Mr. David Mullinax Spartanburg Fire Department	(803) 582-5831	Same as above
Spartanburg Chamber of Commerce, Corner of Pine and St. John Spartanburg, SC 29304	Mr. Jim Thompson, President	(803) 594-5020	Interview Camp Croft, Anniversary Celebration brochure
Spartanburg County Assessor's Office Spartanburg, SC 29304	Ms. Virginia Hafen, Register of Mesne Conveyance Office	(803) 596- 2514	Camp Croft, SC Property Plat of Reservation
Parks, Recreation, and Tourism SC State Parks 1201 Pendleton Columbia, SC 29201	Mr. Joe Watson, Chief Naturalist Naturalist	(803) 734- 0175	Map depicting former Camp Croft ammunition firing ranges and camp cantonment Area
USACE, Charlestown District ATTN: CESAC Charleston, SC 29402	Mr. Wayne Bogan, Local District Representative	(803) 727-4366	Tour, Croft State Park
SC State Parks Croft State Park Spartanburg, SC 29302	Mr. Jerry Perry, Park Superintendent	(803) 585-0419	Interview, Croft Croft State Park map Park Access, gate lock combination
SC State Parks Croft State Park Spartanburg, SC 29302	Mr. Jeff Diller, Park Ranger	(803) 585-0419	Interview

**ACKNOWLEDGMENTS OF ORGANIZATIONS/PERSONNEL**

Organization	Name	Telephone	Nature of Support
U.S. Army Training Center Fort Jackson Museum ATTN: ATZJ-PTM-P Fort Jackson, SC 29207	Ms. Judith M. Matteson Acting Director	DSN 734- 7419	Reports and articles
Pentagon Library Room 1A518 Washington, DC 20310	Staff	(703) 693-6543	References
Spartanburg County Public Library Local History Room 333 S. Pine St. P.O. Box 2409 Spartanburg, SC 29302	Mrs. Martha Dickens	(803) 596-3507	Reports, news articles, and news releases
U.S. Army Military History Institute Carlisle Barracks Bldg. 22 Carlisle, PA 17013	Staff 3611	(717) 245-3611	Text

ORDNANCE AND EXPLOSIVE WASTE  
ARCHIVES SEARCH REPORT  
FOR  
FORMER CAMP CROFT ARMY TRAINING FACILITY  
SPARTANBURG, SOUTH CAROLINA  
PROJECT NUMBER I04SC001603

APPENDIX B

GENERAL REFERENCES AND/OR ABSTRACTS

## APPENDIX B

### GENERAL REFERENCES AND/OR ABSTRACTS

#### Table of Contents

---

1. Army Regulation (AR) 200-1, Environmental Quality, environmental Protection and Enhancement, DA, 23 April 1990
2. Mandatory Plan for Ordnance and Explosive Waste (OEW) Mandatory Center of Expertise (MCX) and Design Center, CEHND 1105-3-9, U.S. Army Corps of Engineers, Huntsville Division, 10 August 1992
3. Defense Environmental Restoration Program for Formerly Used Defense Sites, Ordnance and Explosive Waste, Archives Search Report Instructions, Version 1.0 with changes, U.S. Army Corps of Engineers, Rock Island District, 21 December, 1992
4. Site Safety Plan for OEW Investigations (Appendix A-7 ), U.S. Army Corps of Engineers, Rock Island District, 25 June 1992
5. Camp Croft Landfill Site Screening Inspection Report, SCD 1980 512 750 Spartanburg County, South Carolina, 30 March, 1990
6. Soil Survey, Spartanburg County, South Carolina, Issued April 1968
7. South Carolina Water Resources Commission Water Well Tabulation Data for Spartanburg County as of 26 August 1993
8. Paper titled: The Geology of Croft State Park, Spartanburg County, South Carolina, by Dr. T. Ferguson, Dept of Geology, Wofford College, undated; as extracted from the Croft State Park Management Plan, undated
9. Registration Agreement, State of South Carolina, County of Spartanburg, dated 20 January 1989. Establishes a six acre tract at Croft State Park (Croft Soapstone Quarry) as a protected historical site under the Heritage Trust Program
10. Report No 3, Water Resources of Spartanburg County, South Carolina, dated 1970
11. South Carolina Water Resources Commission Publications, dated 17 August, 1993
12. A History of Spartanburg County, compiled by the Spartanburg Unit of the Writers' Program of the Work Projects Administration in the State of South Carolina
13. History of Spartanburg County by Dr. J.B. Landrum, Dated 1977.
14. HISTORY OF CAMP CROFT, Originator and Date Unknown, Source: Military History Institute (D-1)

15. Narrative Entitled CAMP CROFT, Originator and Date Unknown, Source: Fort Jackson Museum (D-2)
16. Pages 17-21, Narrative Entitled Camp Croft and Annotated PJFW606, Originator and Date Unknown, Source: Fort Jackson Museum (D-3)
17. SPARTANBURG, Host to 75,000 Soldiers Yearly (Climate-Health-Hospitality-Accessibility), Originator and Date Unknown, Source: Fort Jackson Museum (D-4)
18. Excerpts from TM 9-1900, War Department Technical Manual, Ammunition, General, June 1945 (D-5)
  - a. Small-Arms Ammunition
  - b. Grenades
  - c. Mortar Ammunition
19. Excerpts from TM 9-1904, War Department Technical Manual, Ammunition Inspection Guide, 2 March 1944 (D-6)
  - a. Small Arms and Trench Warfare
  - b. 20-mm Ammunition
  - c. Hand Grenades
  - d. Rifle Grenades and Rockets
  - e. Trench Mortar Ammunition
20. Excerpts from TM 43-0001-37, Technical Manual, Army Ammunition Data Sheets: Military Pyrotechnics (Federal Supply Class 1370), February 1977, Change 8 dated 30 September 1991 (D-7)
21. Chemical Agent Identification Set (CAIS), Information Package, U.S. Army Chemical Materiel Destruction Agency, Program Manager for Non-Stockpile Chemical Materiel, Aberdeen Proving Ground, Maryland 21010 (D-8)
22. Excerpt from TM 43-0001-37, Technical Manual, Army Equipment Data Sheets: Chemical Defense Equipment, 12 May 1982, Change 4 dated 30 September 1991 (D-9)
23. Pertinent Camp Croft Data, Originator Unknown, Undated, Source: Fort Jackson Museum (E-1)
24. POST WAR UTILIZATION STUDIES, Camp Croft, South Carolina, War Department, Office of the Chief of Engineers, September 1945 (E-2)
25. Page 139, Listing of Military Locations, includes units within the Fourth Service Command, Originator unknown, Source: Fort Jackson Museum (E-3)

26. Site Survey Report ERDA Project No IO4SC001600, Camp Croft, Spartanburg County, S.C., dated 1984 (E-4)
27. Camp Croft Landfill Sketch from the Camp Croft Landfill Site Screening Report, dated 30 March 1990 (E-5)
28. Generalized Geologic Map of Croft State Park Source: Dr. Terry A. Ferguson, Wofford State College, Spartanburg, S.C. (E-6)
29. Drawing (Sketch) of Croft State Park: Soapstone Quarry, Source: Croft State Park Management Plan, undated (E-7)
30. Survey Open File Report No 64: Geologic Maps of the Pacolet and Pacolet Mills 7.5-Minute Quadrangles, South Carolina, by S. Mittwede, 1989 (E-8)
31. Letter, HQ, Infantry Replacement Training Center (IRTC), Camp Croft, SC, 23 August 1945, Subject: History of IRTC, Camp Croft, South Carolina (F-1)
32. Site Summary Sheet, DERP FUDS Site No. IO4SC001600, Camp Croft Army Training Facility, Spartanburg, SC, 19 September 1991F-1 (F-2)
33. DERP FUDS FDE, Camp Croft Army Training Facility, Spartanburg, SC, Site No. IO4SC001600, 25 November 1991 (F-3)
34. Project Summary Sheet, DERP FUDS CON/HTW Project No. IO4SC001601, Camp Croft Army Training Facility, Spartanburg, SC, Site No. IO4SC001600, 19 September 1991 (F-4)
35. Project Summary Sheet, DERP FUDS HTW Project No. IO4SC001602, Camp Croft Army Training Facility, Spartanburg, SC, Site No. IO4SC001600, 19 September 1991 (F-5)
36. Project Summary Sheet, DERP FUDS OEW Project No. IO4SC001603, Camp Croft Army Training Facility, Spartanburg, SC, Site No. IO4SC001600, 19 September 1991 (F-6)
37. Letter, DA, Office of the Chief Engineer, Ref: File No. 602, Camp Croft, SC, 20 December 1948 (F-7)
38. Certificate of Dedudding, 9800th S.U.-O.E., Det #8, Bomb and Shell Disposal undated (F-8)
39. Memorandum For Record, USACE, SACEN-E (Steve Morrison), 15 August 1984, Subject: Site Visit to Camp Croft, Spartanburg (F-9)
40. Telephone Conversation between Steve Morrison, USACE, SACEN, and John E. Gosset, Sr., Maintenance Engineer at Camp Croft during WWII, 20 August 1984 (F-10)
41. Telephone Conversation between Steve Morrison, USACE, SACEN and MSG High, 48th EOD, Fort Jackson, SC, 23 August 1984 (F-11)

42. Conversation Record between Jeff Beckner, Garraty and Miller and Robbin Blackman, USACE, SACEN, Subject: Camp Croft - location of Wells, 8 October 1987 (F-12)
43. Memorandum, DA, CESASRE-MM, 31 May 1989, Subject: DERP Real Estate Information for Camp Croft, S.C. (F-13)
44. "Note to Jim" from an employee, USACE, SACEN, 5 September, 1990 (F-14)
45. Telephone Conversations between Steve Holdeman, Corps of Engineers, Charleston District and Lt. Harold Hines, Spartanburg County Sheriff, Bomb Squad Unit; Sgt Craig, 48th EOD, Fort Jackson, SC; Keith Windham, Park, Superintendent, Croft State Park; Greg Henschel, Narcotics Division, Columbia, SC (formerly of the 48th EOD), 5 September 1990, Subject: Calls Related to Ordnance at Camp Croft (F-15)
46. Sketch, CESAC, Rifle Range, Whitestone area, Camp Croft, 19 June 1991 (F-16)
47. Memorandum, USACE, Charleston District, Planning Branch, October 15, 1991, Subject: Croft State Park and Vicinity, formerly Camp Croft Army Training Facility, DERP-FUDS Site No. I04SC001600 (F-17)
48. Memorandum, SC Department of Parks, Recreation and Tourism (PRT), Division of State Parks, October 29, 1991, Subject: Croft State Park, formerly Camp Croft Army Training Facility, DERP-FUDS Site No. I04SC001600 (F-18)
49. Conversation Record between Joe Watson, Chief Naturalist, SC Department of PRT and Wayne Bogan, Jr. USACE, Charleston District, 30 October 1991, Subject: Camp Croft - Recently discovered Mortar, Live (F-19)
50. Conversation Record between 48th EOD staff, Ft. Jackson, SC and Wayne Bogan, Jr., USACE, Charleston District, 30 October, 1991, Subject: Mortar Round at Camp Croft (F-20)
51. Conversation Record between Walt Perro, USACE, Huntsville Division and Wayne Bogan, Jr., USACE, Charleston District, 30 October 1991, Subject: Mortar Round at Camp Croft (F-21)
52. Property Plat of Reservation, Camp Croft, SC (Showing location of individual tracts), June 17, 1941, see Document L-12 (G-1)
53. Drawing No. 1021-7 (four sheets), War Department, Office of the Division Engineer, South Atlantic Division, Camp Croft Military Reservation, January 15, 1946 (Accountability assumed by War Assets Administration [WAA] on 19,044.46 Acres, April 19, 1947; see Document L-13 (G-2)
54. Quitclaim, South Carolina, former Camp Croft, 26 May 1949 (G-3)



55. CAMP CROFT 50th ANNIVERSARY CELEBRATION, P.O. Box 15123, Spartanburg, South Carolina 29302, NEWS RELEASE, Camp Croft 50th Anniversary Celebration St. Luke United Methodist Church Festival Committee, July 26, 1991 (H-1)

56. GERMAN POW RETURNS 'HOME', The Spartanburg Herald-Journal, Laura Corbin, Staff Writer, August 9, 1981 (H-2)

57. CAMP CROFT WAS ACTIVATED IN '41, The Spartanburg Herald-Journal Bicentennial Edition, July 3, 1976 (H-3)

58. CROFT PLAYED KEY ROLE IN INFANTRY TRAINING, The Spartanburg Herald-Journal, undated (H-4)

59. ARMY CAMP TO BE BUILT NEAR HERE, SITE ANNOUNCED FOR REPLACEMENT CENTER FOR ARMY, The Spartanburg Herald, November 9, 1940 (H-5)

60. Untitled article, The Paper, September 11, 1991 (H-6)

61. CAMP CROFT CHANGED SOLDIERS' LIVES, The Paper, September 11, 1991 (H-7)

ORDNANCE AND EXPLOSIVE WASTE  
ARCHIVES SEARCH REPORT  
FOR  
FORMER CAMP CROFT ARMY TRAINING FACILITY  
SPARTANBURG, SOUTH CAROLINA  
PROJECT NUMBER I04SC001603

APPENDIX C

GLOSSARY

## APPENDIX C

## GLOSSARY

---

AT	Antitank
BAR	Browning Automatic Rifle
BD/DR	Building Demolition/Debris Removal
CAL	Caliber
CEHND	U.S. Army Engineer, Huntsville Division
CENCD	U.S. Army Engineer, North Central Division
CENCR	U.S. Army Engineer, Rock Island District
CERCLA	Comprehensive Environmental Response, Compensation and Liability Act
CESAC	U.S. Army Engineer, Charleston District
CESAD	U.S. Army Engineer, South Atlantic Division
CON/HTW	Containerized Hazardous and Toxic Waste
DA	Department of Army
DERA	Defense Environmental Restoration Account
DERP	Defense Environmental Restoration Program
DOD	Department of Defense
DOI	Department of Interior
ECM	Earthcovered Magazines
EOD	Explosive Ordnance Disposal
FDE	Findings and Determination of Eligibility
FS	Feasibility Study
FUDS	Formerly Used Defense Site(s)
GSA	General Services Administration
HE	High Explosive
HTRW	Hazardous, Toxic and Radiological Waste
HTW	Hazardous and Toxic Waste
HW	Heavy Weapon
INF	Infantry
INPR	Inventory Project Report
IRP	Installation Restoration Program
IRTC	Infantry Replacement Training Center
M	Model
MG	Machine Gun
Mk	Mark
mm or MM	Millimeter
OEW	Ordnance and Explosive Waste
PA	Preliminary Assessment
PN	Project Number
POW	Prisoner of War
PRP	Privately Responsible Party
PRT	South Carolina Department of Parks, Recreation and Tourism
RA	Remedial Action
RAC	Risk Assessment Code
RD	Remedial Design
RD/RA	Remedial Design/Remedial Action
RI	Remedial Investigation
RI/FS	Remedial Investigation/Feasibility Study
SAA	Small Arms Ammunition
SARA	Superfund Amendments and Reauthorization Act
SCF	Spartanburg County Foundation
SI	Site Inspection
USA	U.S. Army

USACE U.S. Army Corps of Engineers  
USADACS U.S. Army Defense Ammunition Center and School  
USAEDH U.S. Army Engineer Division, Huntsville  
USATCES U.S. Army Technical Center for Explosives Safety  
UXO Unexploded Ordnance  
WAA War Assets Administration  
WD War Department

ORDNANCE AND EXPLOSIVE WASTE  
ARCHIVES SEARCH REPORT  
FOR  
FORMER CAMP CROFT ARMY TRAINING FACILITY  
SPARTANBURG, SOUTH CAROLINA  
PROJECT NUMBER I04SC001603

APPENDIX D  
TEXTS/MANUALS

APPENDIX D

TEXTS/MANUALS

Table of Contents

---

- D-1 HISTORY OF CAMP CROFT, Originator and Date Unknown, Source: Military History Institute
- D-2 Narrative Entitled CAMP CROFT, Originator and Date Unknown, Source: Fort Jackson Museum
- D-3 Pages 17-21, Narrative Entitled Camp Croft and Annotated PJFW606, Originator and Date Unknown, Source: Fort Jackson Museum
- D-4 SPARTANBURG, Host to 75,000 Soldiers Yearly (Climate-Health-Hospitality-Accessibility), Originator and Date Unknown, Source: Fort Jackson Museum
- D-5 Excerpts from TM 9-1900, War Department Technical Manual, Ammunition, General, June 1945
- a. Small-Arms Ammunition
  - b. Grenades
  - c. Mortar Ammunition
- D-6 Excerpts from TM 9-1904, War Department Technical Manual, Ammunition Inspection Guide, 2 March 1944
- a. Small Arms and Trench Warfare
  - b. 20-mm Ammunition
  - c. Hand Grenades
  - d. Rifle Grenades and Rockets
  - e. Trench Mortar Ammunition
- D-7 Excerpts from TM 43-0001-37, Technical Manual, Army Ammunition Data Sheets: Military Pyrotechnics (Federal Supply Class 1370), February 1977, Change 8 dated 30 September 1991
- D-8 Chemical Agent Identification Set (CAIS), Information Package, U.S. Army Chemical Materiel Destruction Agency, Program Manager for Non-Stockpile Chemical Materiel, Aberdeen Proving Ground, Maryland 21010
- D-9 Excerpt from TM 43-0001-37, Technical Manual, Army Equipment Data Sheets: Chemical Defense Equipment, 12 May 1982, Change 4 dated 30 September 1991

610  
-8  
1941  
C. 2

27TH TRAINING BATTALION

D-1

# HISTORY OF CAMP CROFT



Major General Edward Croft.

Camp Croft's first year was a fast moving drama, crowded with as many events, perhaps, as world history saw recorded. The complacent America of a year ago, superficially and apparently safe from immediate war-danger, could have been compared to the tranquil woodlands and farm-fields on which now stands one of the most modern of infantry replacement training centers in the nation.

Crackling rifles and machine guns disturb nature's quietude and marching soldiers trammel upon ground where cotton and tobacco once grew—but all of this activity represents Camp Croft and its powerful answer to Pearl Harbor and Singapore.

A virtual city with a constantly migrating population larger than a typical American town, the modern camp rose and was in full operation within four months. Turning out fighting men by training them in all phases of infantry combat is the major job of Camp Croft, which during its first year, has seen four different permanent post commanders.

Col. Louis A. Kunzig was the first to take the reigns of the cantonment. He was followed by Major General Oscar W. Griswold, who was succeeded in turn by Brigadier General Alexander M. Patch, Jr. In recent weeks

another change came when Brigadier General Clarence R. Huebner became the new camp commander.

Negotiations for the proposed project, first identified simply as "a site in Delmar about five miles south from Spartanburg," were finally completed in late November, 1940, after the war department announced its intention of establishing a camp here. The early days of December saw conferences on land titles and awarding of contracts, the principal ones of which went to Fiske-Carter Company of Spartanburg; J. A. Jones Company of Charlotte, N. C.; and Boyle Road and Bridge Company of Sumter.

Ground-breaking ceremonies were held on December 5, and within a week some 300 carpenters, electricians, laborers and brick masons were at work. Construction was under the direction of Major Neil McKay, who had been named by the war department as camp construction quartermaster, to supervise all camp construction. Recreation programs of all sorts were planned and with it strict enforcement of vice laws was urged. Post Headquarters announced the appointment of Mrs. D. B. Fletcher, Spartanburg resident for 14 years, as Camp Croft's senior hostess. Early April also saw the appointment of Miss Lucille Davis as junior hostess.



in mid-December first thoughts on a name for the camp were heard. Chief among them was the suggestion of Colonel Kunzig, who presented the name of Camp Croft, to honor the late Chief of Infantry, Major General Edward Croft, a native of nearby Greenville, who died in 1938. The name was approved immediately by the Spartanburg City Council, but official war department approval did not come until a month later.

Machinery of all sorts, shapes, and sizes roamed and rumbled over the now activity-filled area as a new city arose over night. By Christmas of 1940 more than 3,000 men were at work tearing down shacks, grading, building offices, installing wires, mixing cement, and laying bricks.

Late in December and early in January pressing problems were faced by construction engineers. Long sieges of rain, shortages of materials and labor, and a serious influenza epidemic balked the progress engineers had achieved early in their work. The morning of January 16 saw more than 2,000 workers fail to appear for the starting whistle. Contractors met the problems with determination and within several weeks sunny skies and quick-recovering workers put smiles on the once gloomy faces of foremen. On January 24 contractors estimated 12,000 were at work on the project.

Statistics, figures, calculations, and estimates had reached by mid-February astronomical numbers. With an additional \$2,000,000 allotted for camp construction, the war department announced its approval to build a \$345,000 laundry establishment.

Sightseers from many miles around took sunny Sunday drives to the multi-million-dollar project and the resulting jam on Pacolet Highway led state highway officials to close the road.

Late in February the cantonment was incomplete but ready for occupation, and on March 7 the first newly-enlisted men arrived and were assigned to B and C Companies of the 33rd Battalion. The outfits became proud and boastful, and justly, for they were the first to be activated at Camp Croft. Several weeks before their arrival, regular army troops, forming the camp's training cadre, had been assigned to the camp. By the end of March the entire 33rd Battalion was activated and Camp Croft's training history began to be written.

Newly drafted men continued to pour in during April, and with spring in full swing eight battalions, the 32nd through the 40th, were filled and actively at their grim work. During this period the 50th Battalion, comprising Negro soldiers only, had also been activated.

Simultaneous with the ever-increasing arrival of men, the construction quartermaster announced that approximately \$500,000 in additional construction would soon get under way. The construction program would include an officers' club, chapels, and several other buildings.

With the "new" city rapidly importing its population, Spartanburg, its nearby "old" city, became active in its interest in Camp Croft. Religious, social, political, and welfare organizations intensified their efforts to make the strangers of Croft "at home."

A blanket declaration in the acquisition of the range area—nearly 16,000 acres of Piedmont farmlands—also

majoried in the developments of April. The filing of this document gave the "go" signal to Major James Barksdale, then Camp Engineer, in the important work of providing drill grounds, rifle, bayonet, and landscape miniature anti-aircraft courses, and ranges for machine gun and 60 and 81-millimeter mortars and hand grenades.

Four major events occurred in May as Camp Croft continued in its progress. On May 5 the first public parade saw the 33rd and 34th Training Battalions impressively march in review. The Service Club was dedicated on May 10 and seven days later all construction under the original contracts was declared "completed." Plans were announced on May 22 for a \$250,000 beautification program. The landscaping included 1,000 acres of Bermuda grass. And so what five months before had been a barren stretch of land became in the month of May, 1941, a military camp with a perpetual busy hum of activity.

A highlight of June was a gigantic farewell parade in honor of Colonel Kunzig, who was then Camp Executive Officer. The entire camp personnel took part. Camp Croft's first commander had been assigned to command Camp Blanning, Fla. Less than a week after the departure of Colonel Kunzig the first graduates of the 13-week basic training course departed from the 33rd Battalion for the 28th Division at Indiantown Gap, Pa. June also saw the opening of a USO drive in Spartanburg.

The ensuing months saw increased training activities, added USO entertainment features for the soldiers, and special programs to make the average soldier's brief stay at Camp Croft a happy one.

Taking the limelight for September was a 4,500-man parade which marched in review before Mrs. Maribel Williams Croft, widow of the late General Croft.

Not to be outdone in sports, Camp Croftites organized a top-notch football team. Known as the "Croft Crusaders" and under the able direction of First Lieutenant Joseph Katalinis, former Georgetown University star, the team played nine games, winning six, losing two, and tying one. With the aid of Stanley Krivik, former Fordham gridder, the Crusaders scored 144 points to their opponents' 32. Boxing and basketball also were participated in commendably by Croft soldiers during the winter.

A religious activity long to be remembered at Camp Croft was the solemn Pontifical Mass celebrated on October 5 on the parade ground by the Most Reverend Amleto Giovanni Cicognani, Apostolic Delegate to the United States. More than 8,000 persons, soldiers and civilians, attended the mass, which was a feature of the three-day 12th annual conference of the Charleston Diocesan Council of the National Council of Catholic Women. On October 27 special ceremonies were held as six Camp Croft chapels were dedicated.

Dances, plays, games, fun—all entertainment—coupled with hard infantry training makes Camp Croft for any about-to-be drafted man a place to long for—and for any about-to-leave soldier a memorable experience.

And so the camp goes on—turning out fighting men to fill Uncle Sam's infantry divisions in the nation's all-out war effort against the Axis. The history-making pages of this cosmopolitan camp—the crossroads of the nation—continue and look forward—forward to victory.

## CAMP CROFT

Croft State Park derives its name from the fact that it was once part of a World War II training area known as Camp Croft. Construction began December 5, 1940, on this Infantry Replacement Training Center and the first group of enlisted men arrived for training on March 7, 1941. By July 31, 1945, 199,839 men had been ordered into Camp Croft for training in all phases of infantry combat. Following the second World War, Camp Croft fell into disuse. In 1949 the State of South Carolina purchased 7,088 of the 19,034 acres contained in Camp Croft for a state park.

Edward Croft, for whom the training center was named, was born in 1874 in Greenville, South Carolina. An 1896 graduate of the Citadel, Croft was commissioned a second lieutenant in the regular army. During the First World War he served as a colonel and temporary brigadier general. For his services, he was decorated with the Purple Heart and Silver Star. Croft was appointed a major general and Chief of Infantry on May 6, 1933. He died in 1938 in Greenville, South Carolina.

COL. JOHN THOMAS, JR.

The upper position of South Carolina including Spartanburg County was Indian territory prior to 1755. The Cherokees threw open a portion of their hunting grounds for settlement in exchange for protection against their old enemies the Creeks. This area contains ten present day counties. Many settlers were attracted by the lure of cheap land and among them was John Thomas who was born in Wales and reared in Pennsylvania.

When war clouds began to loom between the colonies and the mother country a regiment was organized for Spartanburg and Union counties and John Thomas, Sr. was selected to command this new unit. Available evidence indicates that John Thomas lived on what is now Croft State Park. John Thomas, Sr., his wife Jane and his son John Thomas, Jr. played important role in the Revolutionary War in the upcountry. It appears that every member of this family had a personal interest in the patriot's cause.

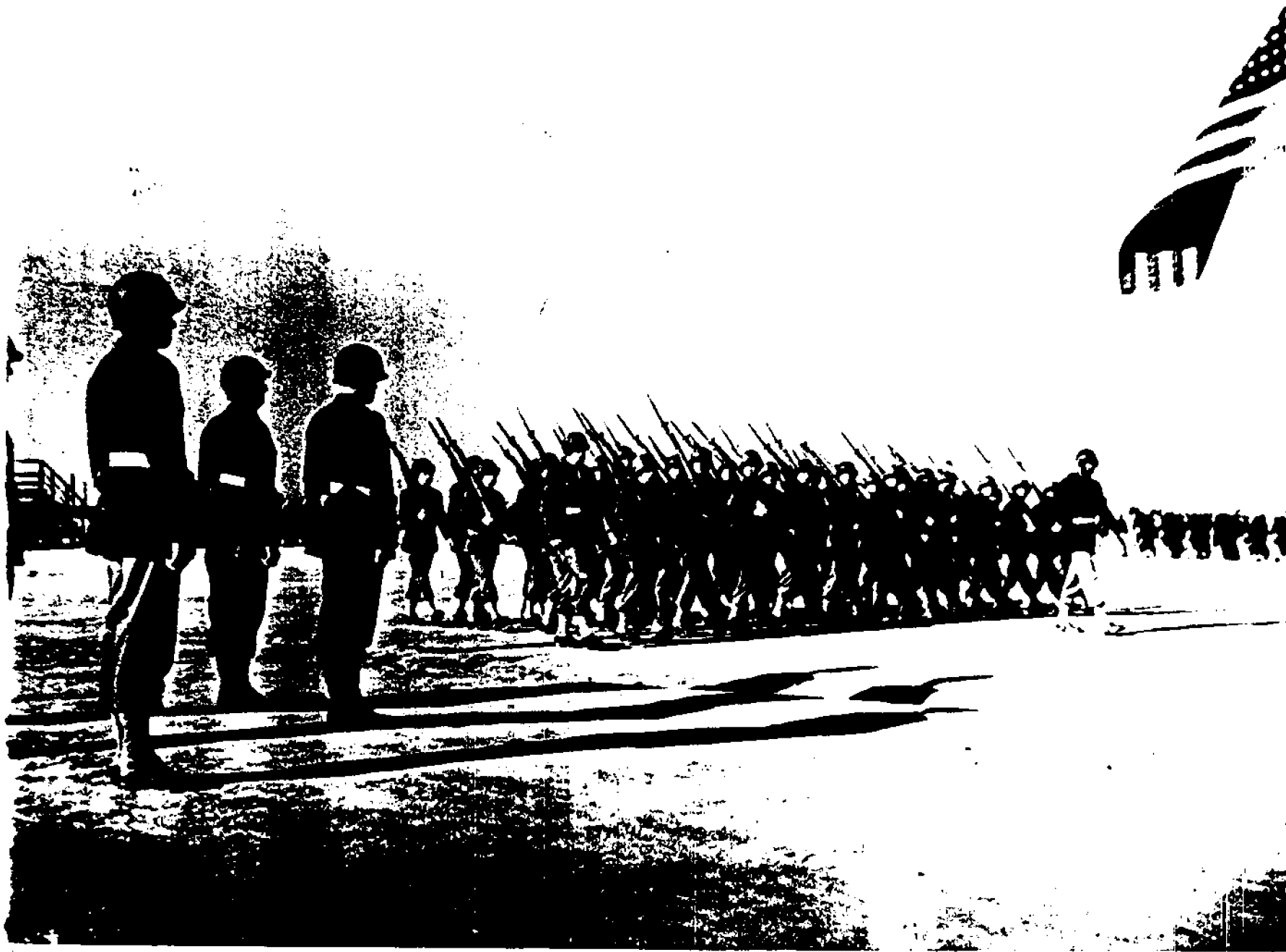

D-2

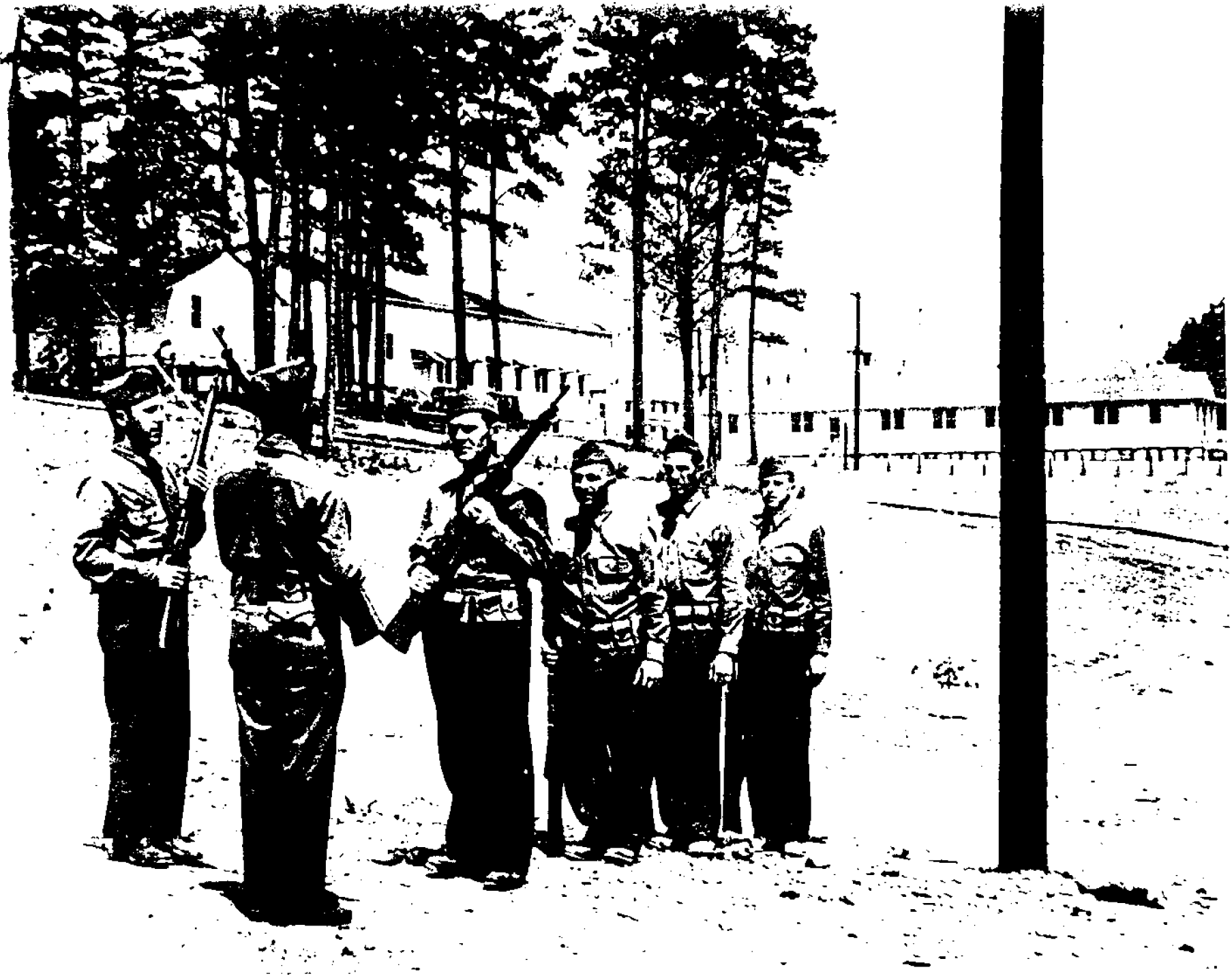

















## CAMP CROFT

Croft State Park derives its name from the fact it was once part of a World War II training area known as Camp Croft.

Edward Croft, for whom the training center was named, was born in 1874 in Greenville. An 1896 graduate of the Citadel, Croft was commissioned a second lieutenant in the regular army. During the First World War, he served as colonel and temporary brigadier general. For his services, he was decorated with the Purple Heart and Silver Star. Croft was appointed a major general and Chief of Infantry on May 6, 1933. He died in 1938 in Greenville.

When the land for Camp Croft was acquired, there were 263 families living in the area had to be moved to facilitate the conversion of the farm land into a military base. By March 14, 1941, 109 families moved, 55 had made arrangements to move, and 99 families were unable to find new quarters. To expedite the removal of the remaining families, the government built 20 pre-fabricated houses on the West Farm, about a mile from Pacolet. Eight men could assemble one of these houses in a day costing less than \$1,000. Apparently some of the families that were forced to move were indigent due to the depression, as some reports referred to them as squatters.

The Farm Security Administration employed Jack Delano to make a photographic record of the plight of the families to be moved to make room for Camp Croft. Some of these photographs could make an interesting exhibit at the park.

Construction began December 5, 1940, on this Infantry Replacement Training Center and the first group of enlisted men arrived for training March 7, 1941. By July 31, 1945, 199,839 men were ordered to Camp Croft for training in all phases of infantry combat. Training lasted seventeen weeks, after which these soldiers were shipped out to all points of the globe. A wide range of human emotions were experienced by these men as they fought fatigue and home sickness. They also shared the joy of making new friends and the pride of finishing a long march or scoring high on the rifle range. Statistics from the camp chapels tell of some of these emotions. There were 483 marriages, 76 baptisms, and 53 funerals in a little over four years.

Here the rich and famous trained along with the farm boys and the big city dudes. Known personalities that served at Croft included:

Zero Mostel - entertainer  
 Mel Allen - sportscaster  
 Howard Krist - of the St. Louis Cardinals  
 Lefty Lefebvre - of the Washington Senators

James R. Taber - of the Boston Red Sox  
"Duke" Abbrezza - half back, Green Bay Packers  
Tiger Fox - light-heavyweight boxer

Some individuals gained notoriety while serving at Camp Croft including Private Michael Umhofer. He learned that he did not weigh enough to qualify for airborne training so he ate ten bananas, drank a quart of milk plus a gallon of water just before the examination. He qualified with a little over four pounds to spare.

Others made a name for themselves in the service after leaving Camp Croft. One of these was Chaplain James M. Liston, who sank with a troop transport after giving his lifebelt to a soldier.

3000 foreign-born soldiers were naturalized as American citizens while at Croft, including Henry Kissinger, who became U.S. Secretary of State and presidential advisor.

Among the well known visitors to Camp Croft was Gen. George C. Marshall, who at the time was Chief of Staff of the U.S. Army. He later served as Secretary of State and Secretary of Defense. He was awarded the Nobel Peace Prize for formulating the Marshall Plan to aid war-torn nations.

Another visitor to Camp Croft was Charles A. Beard, American author and historian.

During the hectic war years, several different generals served as commander at Camp Croft. Notable among them was Gen. Alexander Patch, who served at Croft from August 25, 1941 to January 19, 1942. In the spring of 1942, he was sent to help the French defend New Caledonia in the South Pacific and was appointed commander of that Task Force. In the very early days of 1943, Patch, as commander of American forces, led his troops to their first major land victory at the Battle of Guadalcanal. In March 1944, he became commanding general (four stars) of the U.S. Seventh Army. As part of the invasion of France, this force advanced up the Rhone Valley, captured Alsace in the winter, the Saar by March 15, 1945 and crossed the Rhine on March 26th.

Other generals that served at Croft also led combat units, including Major General Oscar W. Griswald. Griswald was Commander of the US XIV Corps which fought in Guadalcanal, New Georgia and the Philippines. In January 1945 the XIV Corps was in the front line fighting the Japanese in the reconquest of Luzon.

A few days in thousands of lives were touched by Camp Croft as it served as an induction center where civilians were "welcomed" into the army. Most of these men were sent to other camps for training.

Camp Croft also featured a prisoner of war camp for German POWs. Gerhard Ritters of Krefelt, Germany was one of 250 POWs interred at Croft. Captured as a nineteen-year-old in North Africa by American forces, he spent two years at Croft. Ritters has made more than one trip back to Spartanburg to renew some special memories of his youth.

**D-3**

For four years, Camp Croft was much like a bustling small town. The following statistics gives an idea of what it took to house and train 200,000 soldiers.

Seventy-five tons of food were delivered daily to the mess halls, of which five tons were potatoes.

Over 6,000 loaves of bread were baked daily for camp consumption.

Each man in the camp was allotted 5 1/2 pounds of food daily.

There were 91 mess halls on the post, taking up 265,000 sq. ft. of floor space.

There were 321 barracks covering a total of 1,473,178 sq. ft. of floor space capable of housing 19,115 men.

There were 68 hospital buildings covering an area of 17,938 sq. ft. and a grand total of 969 buildings of all types covering 2,899,751 sq. ft.

The finance office, during the peak load at Croft, paid in excess of \$1.5 million per month by cash and check to military personnel.

The finance office issued more than 13,000 checks each month.

Total monthly disbursements were more than \$2.5 million. In addition to military personnel payments, more than 3,250 civilians were paid, more than half semi-monthly.

More than 72,000 patients were hospitalized in the station hospital and more than 334,345 out-patients were treated.

The four post theaters could seat 3,387 persons.

The two libraries on post had more than 11,000 volumes for soldiers to choose from.

The publications office used more than 33 million sheets of mimeograph paper.

The motor pool had 288 vehicles: 129 were jeeps.

The Military Police Officers made a total of 7,241 arrests.

The weight of mail received daily for the camp exceeded 4,800 lbs.

The men at Camp Croft enjoyed the hospitality of the city of Spartanburg, which had six USO clubs. The men also had their own clubs at the camp, including a Service Club, Officer's Club and the regimental headquarters. Many Spartanburg residents visited the camp to partake of the entertainment offered there.

Camp Croft was used in 1945 as a separation point for discharged soldiers. On Sept. 19, 1945, First Sergeant Joseph P. Hudock of Warren, Penn. was the first man discharged through Camp Croft.

Soon after the end of World War II, Camp Croft fell into disuse. On Jan. 25, 1947, at the request of the Spartanburg County Legislative Delegation, city council, Chamber of Commerce, Veteran Housing Commission, civic clubs and other organizations in the county, the trustees of the Spartanburg County Foundation met with the War Assets Administration concerning the purchase of Camp Croft. It was decided the camp would not be converted into a permanent military base.

The trustees of the County Foundation bought the camp in March, 1947, for more than \$1 million. David W. Anderson was placed in charge of Camp Croft surplus.

The foundation was given authority to dispose of the surplus and property in any way they saw fit, and the profits they obtained were to be used for the benefit of the county.

The area around the camp's warehouses and railroad was developed into a small industrial park and the area that once featured barracks is now a residential neighborhood. In 1949 the State of South Carolina purchased 7,088 of the 19,034 acres contained in Camp Croft for a state park.

A casual observer visiting the area today would see little to remind him this was once an active army base. The area around the railhead is now a busy industrial park known as Camp Croft. Some army buildings remain in this area including a fire station, ice house, theater and a few warehouses and service buildings. The camp's 2.23 million gallon water tank remains today as a prominent landmark. When built, this was the largest water tank in South Carolina. The section of the camp that once featured over 300 barracks is today an attractive residential area. An old veteran visiting the area today may notice that the street layout is the same and many of the street names indicate this was once an army post including Headquarters Loop, Ridgeway Avenue, Patton Avenue, Pershing Drive, and Patch Drive.

Most of what is now Croft State Park was once the down range or impact areas for the firing ranges at Camp Croft. This area was also used for various exercises when the ranges were not in use. It is not unusual to observe foxholes, barbed wire entanglements or spent bullets on the undeveloped areas of the park. The most noticeable features of the old camp to be seen on the park are several target pits as well as some above ground bunkers to protect the men who operated the targets. There are also some simulated pillboxes for practice assaults and several ammunition storage bunkers. These elements are located on the "special features" map as "bunkers." Most of these "bunkers" are made of cement and require no maintenance, however, the target pits should be fenced or covered to keep wildlife and/or park visitors from stumbling into them. One item of special interest is a bunker where the men that were working the target scratched or penciled their names on the walls. Many of these names are still legible today and all



necessary measures should be taken to protect them if this area is made accessible to the public.

Records indicate there were ranges at Camp Croft for rifle, pistol, machine gun, mortar (60 mm. & 81 mm.), as well as anti-aircraft and anti-tank ranges. One of the anti-tank ranges featured a moving target that ran along a small track. The bed for this track can still be discerned on the park.

Most of the acreage of Camp Croft reverted back to private property after the war. The majority of this land is located south and east of the present state park acreage and also featured some firing ranges and impact areas. One outstanding feature now on private land is the remains of a mammoth rifle range near the town of Whitestone. The target pit for this range is a cement wall that stretches nearly one half mile across what is now a pine forest. If this feature was on public property it would offer some interesting interpretive possibilities.

There is a need for research into the possibility of photographs of Camp Croft as these may be of value for future interpretation. A search should also be made of official records that would tell what weapons were used at Camp Croft. A description of the training could also provide interesting interpretation in the future.

PJFW606/slp

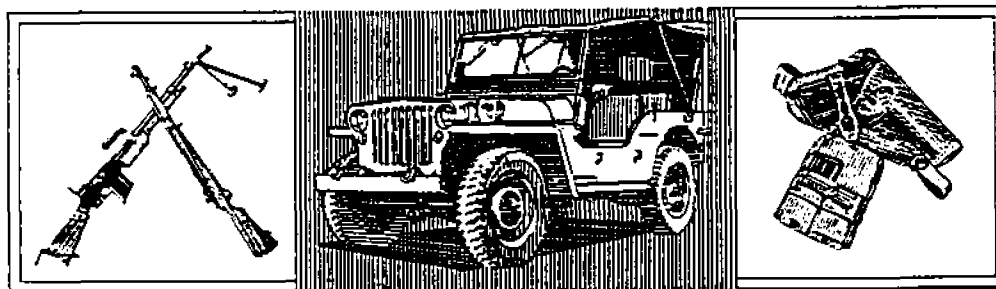

# SPARTANBURG

*Host to 75,000 Soldiers Yearly*



CLIMATE · HEALTH · HOSPITALITY · ACCESSIBILITY

**S**PARTANBURG, South Carolina, is one of the interesting towns of the South, and the county seat of Spartanburg county, one of the important counties of the United States because the county is first in cotton textiles. It is furthermore one of the top flight agricultural counties of the country. The city's location gives it everything in transportation and communications. It has five railroads, eight through highways, Plantation pipe line, air lines, telephone and telegraph trunk line cables, two radio stations, and morning and evening daily newspapers.

If you look through this book, you will see pictures of people and places recording life and its surrounding in Spartanburg as the country is in the midst of war.

You will see marching soldiers in the streets. You will see an industry meeting emergency demands. You will better understand the meaning of greater agricultural production through soil conservation. You will realize how deeply interested the people of this county became in the ceremonies that

● *North Church Street*

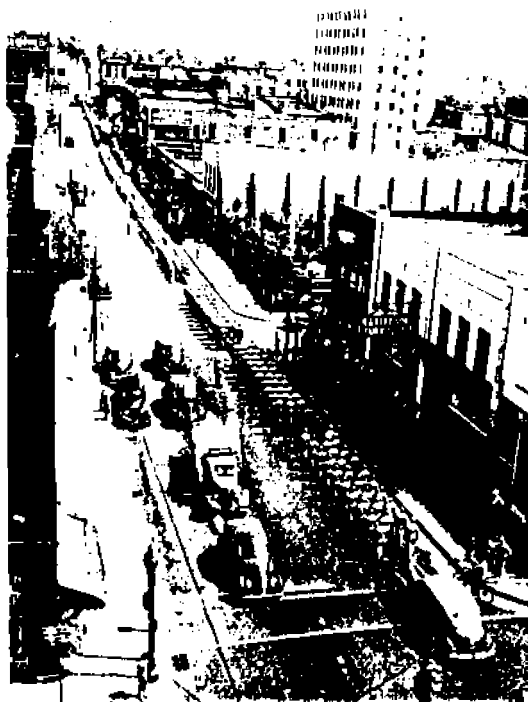

● *East Main Street*

rededicated all effort to the principles involved in the war the Allied Nations wage.

There are pictures of churches, schools, colleges, farms and factories, and in the center of the book are contrasting scenes. Morgan Square, as the photographer recorded the scene in 1884 and the same Morgan Square as the camera reveals it in 1942. From these contrasting photographs you may write any one, or all of the stories that have been written in sixty years, of what has happened in the South, or in the country.

Spartanburg is a rolling, red hill country, where the mountains begin, and Spartanburg City grew up where the ridges meet. The meeting of these ridges, and the gaps in the mountains to the northwest, are responsible for the railroads that make the city one of the important rail centers in the Southeast. You can come to Spartanburg by Pullman without change from Chicago, Cincinnati, New York, New Orleans, or Jacksonville.

Historically, Spartanburg is Revolutionary. In the days of the Revolution it was a battle ground region. Ferguson and Tarleton marched over the soil of Spartanburg. Tarleton was defeated at Cowpens, and Ferguson was killed at Kings Mountain.

In the First World War, the National Guard of New York State trained at old Camp Wadsworth. Camp Croft today is one of the Army's Infantry Replacement Training Centers.

You may not get the idea at once, but the picture on this page is a Home Front Scene. Thousands of soldiers are in training in Spartanburg and thousands of men and women are working here, to clothe the armies and to supply the Allied Nations with the textile products war demands.

The Army and Navy E means service worthily rendered back of the front lines, on the home front. These honors came to textile plants in this county, and in gratitude and recognition the city and county gathered

on the fighting fronts may speedily accomplish victory over our enemies.

"Further, we hereby broadcast an invitation and a challenge to every other community in the nation to join with us in this movement of rededication, so that human freedom and honor and decency and a righteous peace may once again become the guiding principles of mankind.

"And may God give us the strength and courage, no matter how great shall be our personal sacrifices, to fulfill our responsibilities to those on the fighting fronts."



• Mass Vespers  
Service in the  
"Forest of Arden,"  
Converse College

to rededicate the efforts of all interests to "human freedom, honor and decency, and a righteous peace."

The great open-air gathering, a section of which appears, repeated in unison a pledge, in these words:

"We, the people of Spartanburg County, South Carolina— from the farms and factories, from the towns and cities— assembled here in a solemn ceremony, rededicating ourselves to the true ideals of democracy, do now pledge ourselves, hopefully and prayerfully, to do our utmost in whatever capacity we are able to serve, so that our men and women

That reflects the patriotic impulse directing the energies and efforts of Spartanburg people in this moment of conflict between liberty and bondage.

The scene here is in the "Forest of Arden" on the campus of Converse College on the afternoon of Sunday, May 30, 1943. City officials, the commanders of Camp Croft, Chamber of Commerce officers and an audience of five thousand gathered in this theatre of mottled shade and sunshine to hear an Army band play, a Negro choir sing, and to listen to a remarkable address by Dr. Ellis A. Fuller.

## What the Churches Mean to Spartanburg . . .

If it were possible, over night, to take out of Spartanburg all that the church has contributed to the various phases of its life, the city would not be recognizable the next morning. First, the churches themselves would disappear. Then, in swift order, the courthouse, the hospitals, the public schools would go. If the libraries remained, their shelves would be depleted, as thousands of books would disappear and others would be deleted of that portion which came from the church.

The business life of a city depends upon the church. Honesty and integrity come from worship, and not as mere policy. The whole structure of our commerce is built upon the trustworthiness of human beings. The presence of the churches and what they have brought to this city, or any city, directly affects the value of physical property, as all dealers know.

There is a more concrete sense in which the church has built Spartanburg. The first institution of serious importance in the city was Wofford College. Then Spartanburg was but a village, into whose life Wofford students brought thousands of dollars annually, a village that, through the coming and going of Wofford students, was rapidly and favorably advertised to the outside world. Many of her outstanding citizens came to Spartanburg and made it their home because of the presence of the college. Wofford was founded by a Methodist minister and is the property of the church.

Much that has been said of Wofford's contribution to the city may also be said of Converse College. While not owned directly by any denomination, the founders of Converse were themselves church leaders. For the greater part of her history, Converse had as president a Presbyterian minister. Thus it may be seen that actually the church has largely inspired and molded the development of this great educational institution.

A third Junior Col by the Met by a Met stitution. I three, can the growth city to the sisters. If her faculty are begun upon the n: This unique by the en America, I wherever I icals have resulted in Spartanbur ner part t

Thus i churches, the morals ulated tra the value o impetus to ment of ce

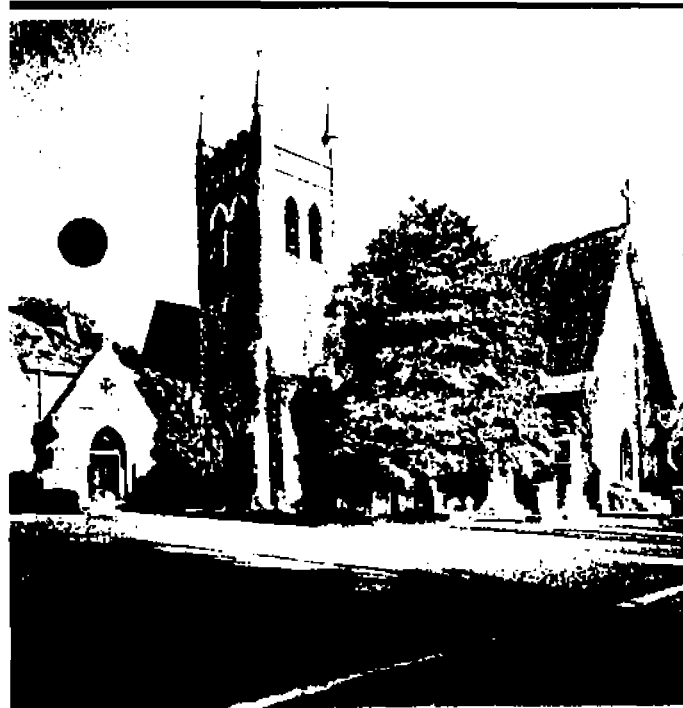

Episcopal Church of the Advent



• The First Baptist Church



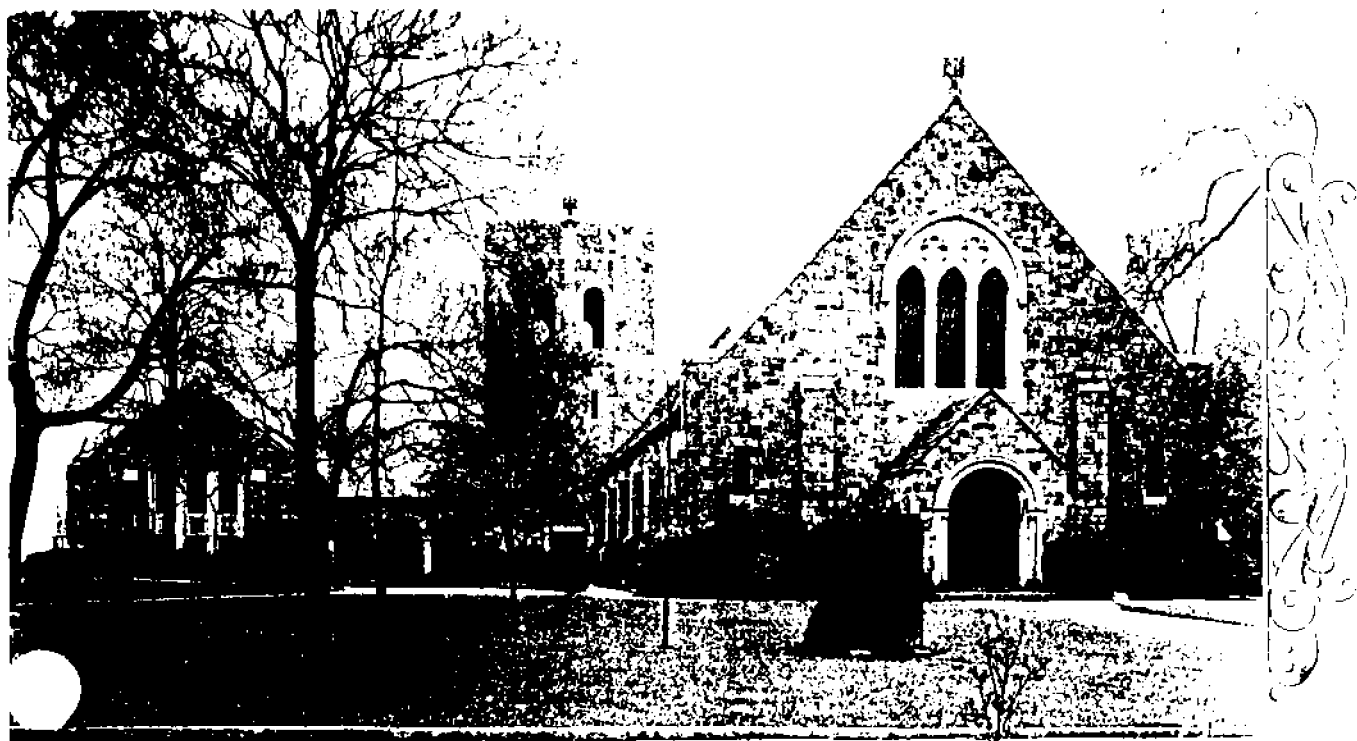

• *First Methodist Church*

A third institution, Spartanburg Junior College, owned and operated by the Methodist Church, was founded by a Methodist minister. This institution, being the youngest of the three, cannot claim to have affected the growth and development of our city to the same extent as her older sisters. It is true that the influence of her faculty, student body, and alumni are beginning to exert an influence upon the moral life of the community. This unique institution, because owned by the entire Methodist Church of America, has been widely publicized wherever her misnomers or periodicals have gone. This publicity has resulted in advertising the city of Spartanburg as the home of this prominent part-time school of the church.

Thus, it may be seen that the churches, in addition to influencing the moral life of the citizen, have stimulated trade, protected and enhanced the value of our property, and exercised a potent force in the growth and development of educational institutions.



• *Central Methodist Church*

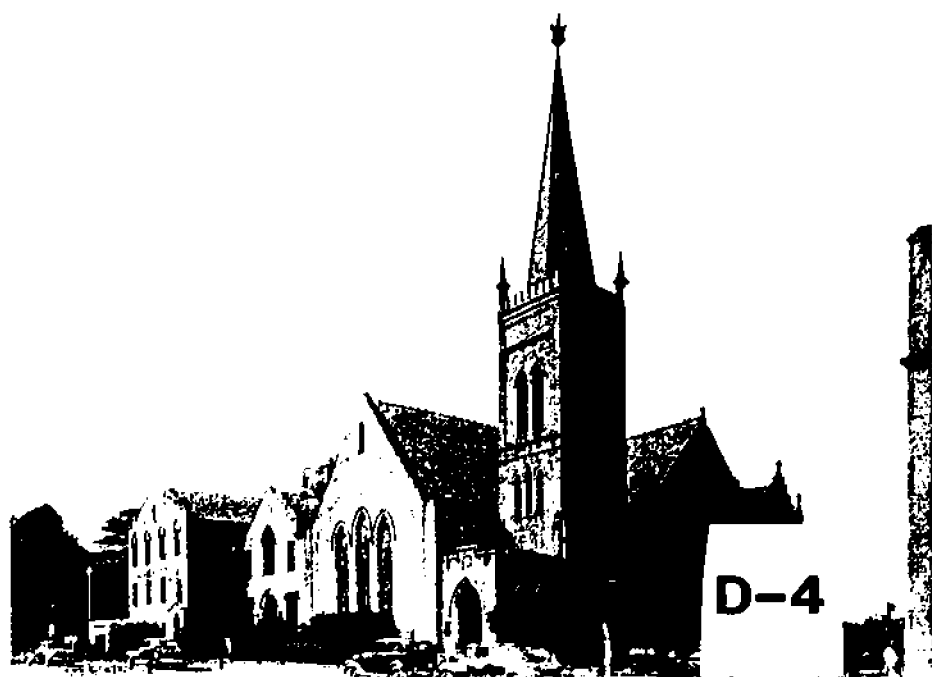



• On the opposite page are views of the Main Buildings of Wofford and Converse Colleges



• Pine Street Grammar School

Spartanburg is a city of schools and colleges. Wofford College, for young men, established in 1854, one of the pioneers of Christian education, fostered by the Southern Methodist Church, launched the village of those days on its way.

In 1889, Converse College, for young women, was established and is today one of the great colleges of the South.

Cedar Spring, the State school for the deaf and blind, is located here, rich in history of local interest and pride.

The Spartanburg Junior College, where education and employment go hand in hand, is another educational enterprise, springing from the spirit of the community interest in learning.

Under these is the city's public school system of eleven splendid units of graded schools, through junior high schools to the senior high school.



• St. Paul's Catholic Church





Spartanburg  
County Is  
First In  
Cotton Textiles

• Cotton in process

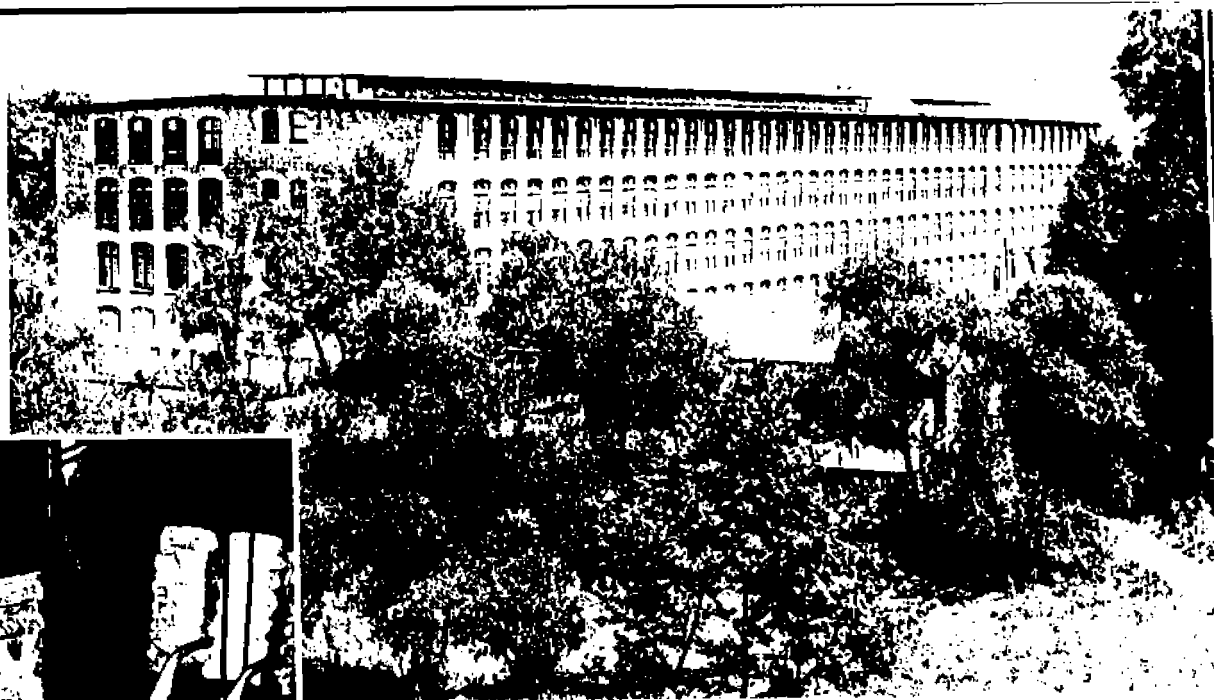

• Home of spindles and looms

With the war Spartanburg County stepped into first place in cotton textiles, leading the South, and thereby the nation. The old slogan, "The mills to the cotton," has prevailed.

An interesting presentation of the industrial expansion taking place in Spartanburg County between 1929 and 1942 is provided by figures taken from the most recent report of the South Carolina Industrial Commission and published in March 1943 in Pamphlet No. 9 by the South Carolina State Planning Board.

In 1929 industries in Spartanburg numbered 99. By 1942 the number of industries were 125.

Persons employed in industry in Spartanburg County in 1929 numbered 12,265. Industrially employed in 1942 were 22,863 persons.

The value of the manufactured products in 1929 was \$46,613,101. In 1942 the value of the county's manufactured products had reached \$152,779,267.

These figures reveal a gain of 228 per cent in the value of Spartanburg County's manufactured products.

The beginning of industrial diversification is revealed in this report. Finishing plants, garment making, wood preserving, and machine shop expansion are some of the things reflected in this industrial expansion record. In due time, plastics and mechanical operations involving precision will be factors of the county's industrial progress. These are beginning.

A building housing a cotton mill is shown on these pages, together with illustrations of the progress of cotton from the

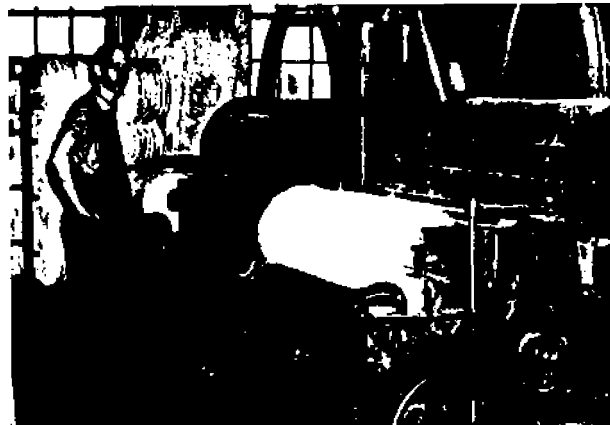
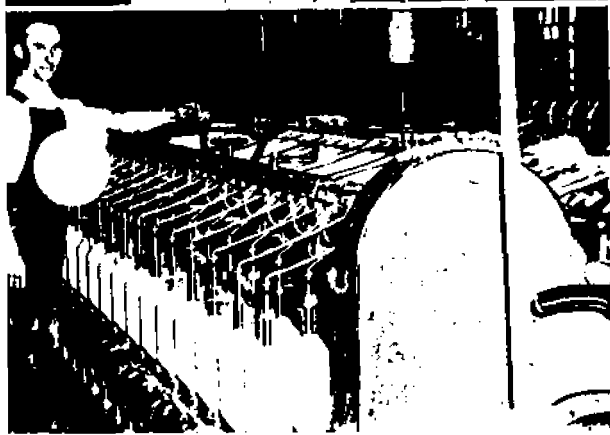

"picker to the bolt" or from the bale opened in the mill to the cloth wrapped and ready for the market.

And there is power in these hills. In the beginning the mills sought shoals, developing their own power, and some of this water power is in use to this day, but long since the great power development, along the fast flowing streams from the mountains to the sea, brought towers and transmission lines to the hills and valleys of the Piedmont.

This leaves no question as to available power in this part of the county. Power is here, for existing industry, and for any that may come. It is also here for rural electrification, so generally distributed throughout the county at this time as to make rural development one of the interesting things happening. And this means much to industry. It means changing agricultural methods from "one crop" farming to "living at home" on small farms, a condition definitely designed to contribute to a wholesome union of industry and agriculture. More and more the people employed in the cotton mills live on productive farms.

What the building of splendid highways did not bring about, fifteen or twenty years ago, in the movement from town to country, rural electrification is now bringing about.

So the long view of this region is one in which industry and agriculture complement each other.

In the early days of the textile industry in the region the "mill village" was essential. The plants for the most part were in remote places, where water was to be had, so people employed had to be housed—and by the manufacturing companies. Today the villages remain in large part, but employees working in the mills are by no means confined to the residents of these villages; they live in the country around about, and in the small towns, and reach the plants, by bus or private cars, over dependable roads.

● *Hydro-electric power*

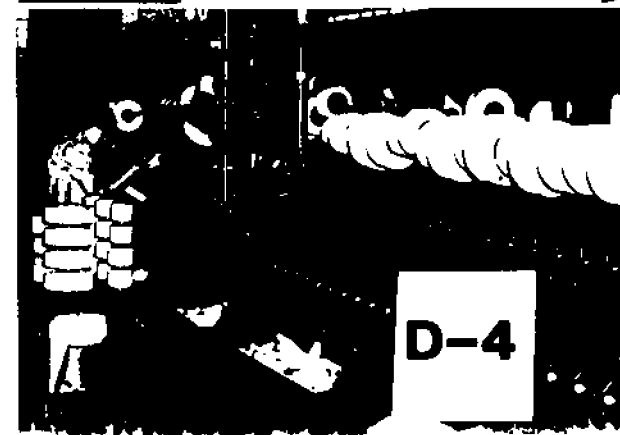
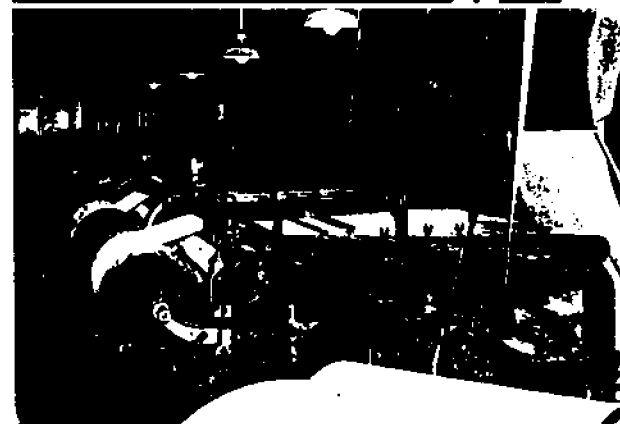
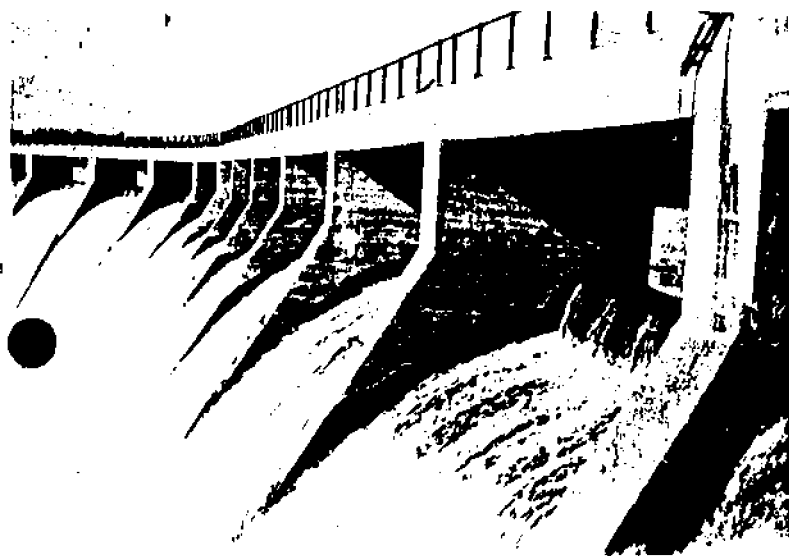



● *Mr. Jackson thanks his "stars"*

Out of the idea that there should be recognition on the part of the whole community of the splendid record being made by the men and women employed in the textile industry, there came "The Textiles Go To War" celebration, held in Spartanburg, May 30-31, 1943.

Recent events of that elaborate program are recorded in pictures on these pages. More than twenty

● *Mr. and Mrs. Byrnes and friends*



thousand persons sat through a five-hour program at Duncan Park. The high point of that day was reached when former United States Supreme Court Justice James F. Byrnes, now Director of War Mobilization, appeared in his home town to deliver a notable address. Mr. and Mrs. Byrnes are pictured on the lower left, seated among friends, intent upon events taking place on the platform.

In the oval, Mr. Walter Jackson, co-chairman of "The Textiles Go To War" committee, is revealed thanking the "stars" of the day's program for their contribution to the success. Below, to the right, is Homer Rodeheaver and his troupe.

There were queens, of course—twenty-six of them. Beautiful girls from as many textile plants of Spartanburg County. The young lady crowned queen of the queens is Miss Nellie Maude Lanford of Woodruff. Some of her attendants are pictured.

At the top, to the right, on the opposite page, is a scene from the Mass Vesper Rededication Service held on Converse campus, showing General D. S. Wilson and Colonel F. D. Griffith, Jr., of Camp Croft, among other distinguished guests attending.

In the center of the opposite page appears a group of



● *Homer Rodeheaver*



• Miss Nellie Maude Lauford

Spartanburg attractive young ladies, modeling costumes of camoullage cloth produced in one of the textile plants of this county for the government's war needs. It is not difficult to believe that in these garments these young ladies were unrecognized by their closest friends.



• Some of the queen's attendants





## MORGAN SQUARE » 1884

Fifty-eight years passed between the taking of these photographs of Morgan Square, named in honor of General Daniel Morgan, commanding the American forces in the "Battle of the Cowpens", and a little contemplation in this connection will disclose the story of the region's progress since the horse and wagon days.

The identical area is shown in both photographs, but there is a change in the point of view. The old picture is looking west, the new is a view of The Square looking east. The statue of General Morgan, appearing in the center of each, was erected in 1881, 100 years after the "Battle of the Cowpens," by the

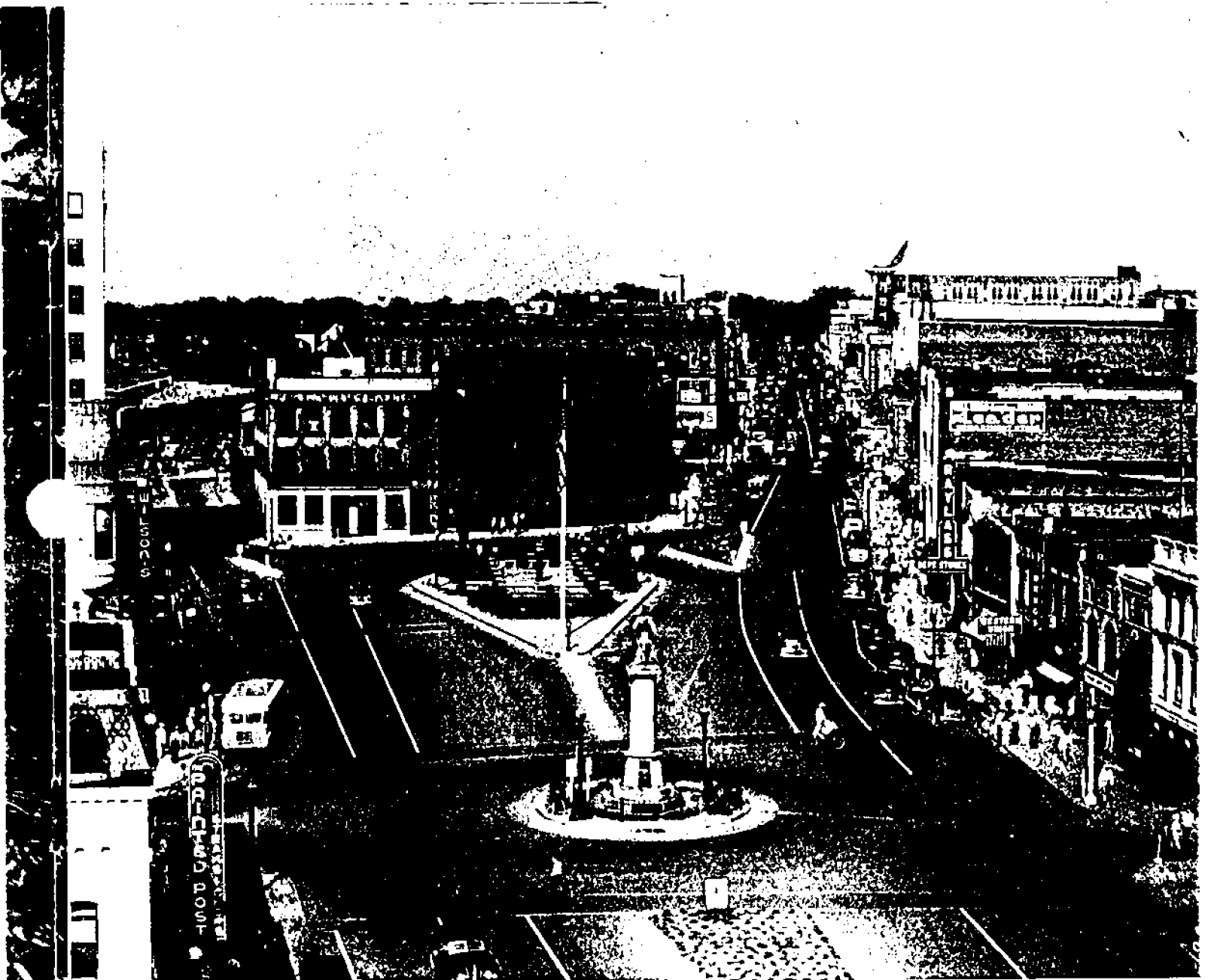

## MORGAN SQUARE » 1942

thirteen original states and the state of Tennessee.

Who took the photograph of "The Square" in 1884? No one seems to know certainly, but the thought is that it was taken by S. C. Monzon, a photographer of the town at that time, and father of the late Bishop Edwin Monzon of the Southern Methodist Church.

None of the buildings on the left in the old picture are standing today. The imposing tower ornamented the old post office and "opera house." The building with the columns was the county courthouse of those days. In between these structures was the old "Spartan Inn."



• Scene from annual dinner

The tenth year of the soil conservation program in Spartanburg County was celebrated at the annual dinner of the Spartanburg Chamber of Commerce on March 3 this year. Dr. H. H. Bennett, of Washington, D. C., Chief of the U. S. Soil Conservation Service, seated above at left, was the principal speaker. The following day, Dr. Bennett addressed a farmers' meeting, which included a panel discussion on "Natural Resources in Peace and War."

As headquarters for the first erosion-control demonstration program in the Southeast, which was established in the fall of 1933, and as the location of the Regional Office of the Soil Conservation Service since January 1936, Spartanburg has been the hub of soil conservation activities in the Southeast, from the inception of the nationwide soil conservation program. Service activities in the nine Southeastern states of Virginia, Kentucky, Tennessee, North Carolina, South Carolina, Georgia, Florida, Alabama, and Mississippi are directed from the regional office here.

The groundwork for increased production developed in this region during the past ten years through a program of erosion control, sound land use, improved pastures, more hay and grazing crops, and other conservation farming practices has provided a sound basis for meeting the increased needs for meat, milk, poultry, and other farm products vital to the war program. Increased production through conservation is being demonstrated by more than 70,000 farmers who are carrying out complete conservation programs developed in cooperation with 169 farmer-organized, farmer-operated soil conservation districts in the nine states of the Southeastern Region. These districts embrace 141,000,000 acres.

Some of the soil conservation practices of special importance to the agriculture of Spartanburg County

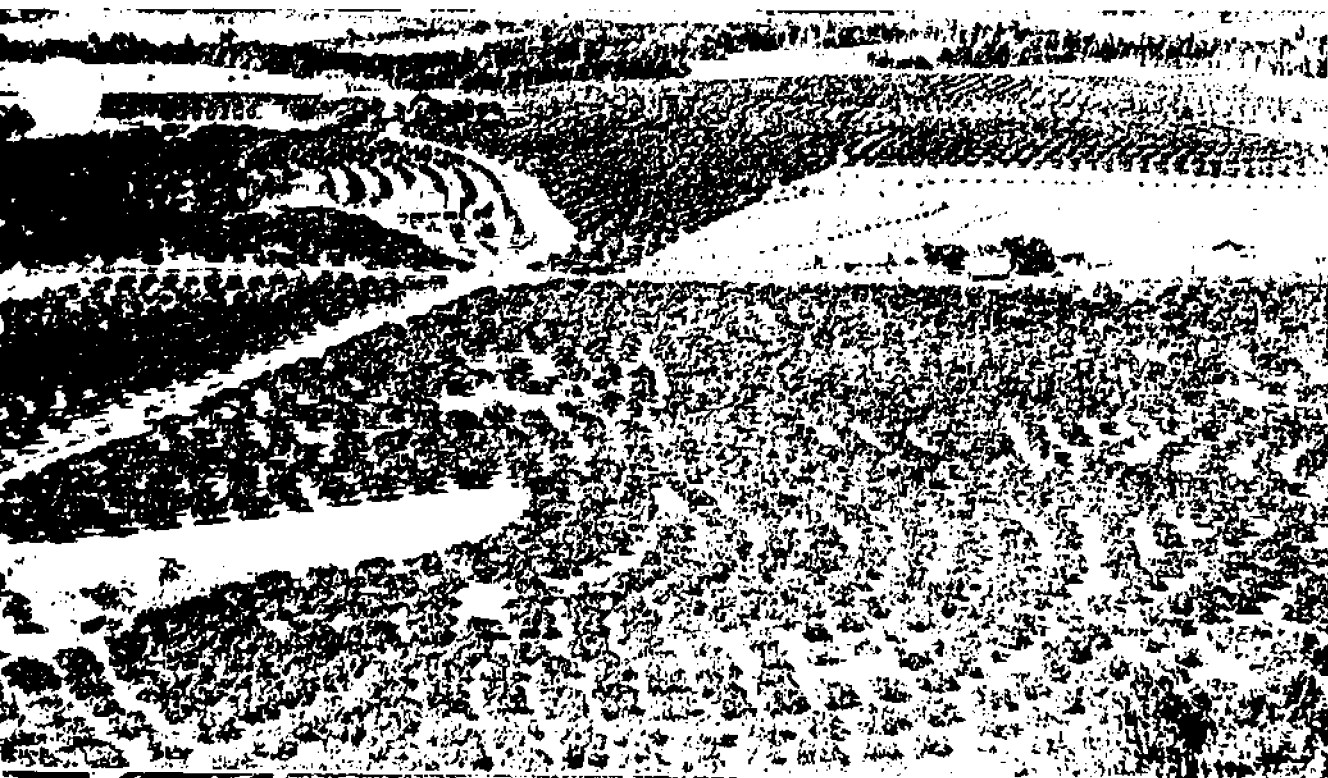

• Peach orchard planted on contour

are shown in the accompanying scenes. In the view below is a contour planted peach orchard, where the hazard of soil losses, *such as formerly occurred in straight-row plantings*, has been reduced by terracing and planting rows along the contours of the slope.

The new pattern of agriculture designed to control the loss of fertile soil on cultivated land through terracing and contour planting of cotton, corn, grain, and hay crops in alternate broad bands or strips across the slope is illustrated in the view at the right of strip farming on a Spartanburg County farm. Crop yields are increased by the use of winter and summer legumes and rotating the crops within the strips from year to year.

Sound land use is strikingly illustrated in the view below, where a steep, severely eroded hillside has been planted to kudzu, a perennial hay and grazing crop, which is providing abundant feed for farm livestock, *as a part of the conservation program*. The effective use of worn-out land for producing perennial hay crops like kudzu and sericea lespedeza is becoming increas-

● *How kudzu screens a gullied hillside*



● *Strip farming*

ingly important as farmers in Spartanburg County and elsewhere throughout the Southeast are turning more and more toward livestock as the basis of a sound and permanent agriculture.







• *Converse student picks cotton*

• *Here picking cotton is serious business*

Cotton is the largest cash crop in Spartanburg County, and the county has been for years one of the three top counties in the state in production. In the past the production has been as high as 85,000 bales, but since government restriction on acreage has been in effect the yield has probably not exceeded 55,000.

The cash return from a cotton crop depends upon the price, of course. When a bale is dropped from the gin, it is weighed at once, and tips the scales a little below or a little above 500 pounds. Most of the cotton is sold then and there, at the day's market. And most of it goes directly to cotton mills in the county.

If cotton is selling at 10 cents, a bale is worth \$50. If 20 cents is the market, the value is \$100.00. "An inch or better" is good cotton in this region. Longer fiber brings a premium usually.

Cotton is picked by hand. It is taken to the gin with the seed in it. Generally 1,300 pounds of seed cotton will produce a 500-pound bale and 800 pounds of seed. The price of seed goes along generally with the price of cotton, and brings about a fourth of the price paid for the cotton.

Cotton is planted in this region between April 15 and May 1st. Sometimes a few days earlier and sometimes a few days later. Since "boll weevil days," the earlier the better. Once planted, the next question is the "stand," which means how did it come up? Then cotton is "chopped," which means thinning it to two or three plants in the hill, about twelve or fifteen inches apart. The hotter, the better this young cotton grows. Cotton wants hot nights, if no one else does.

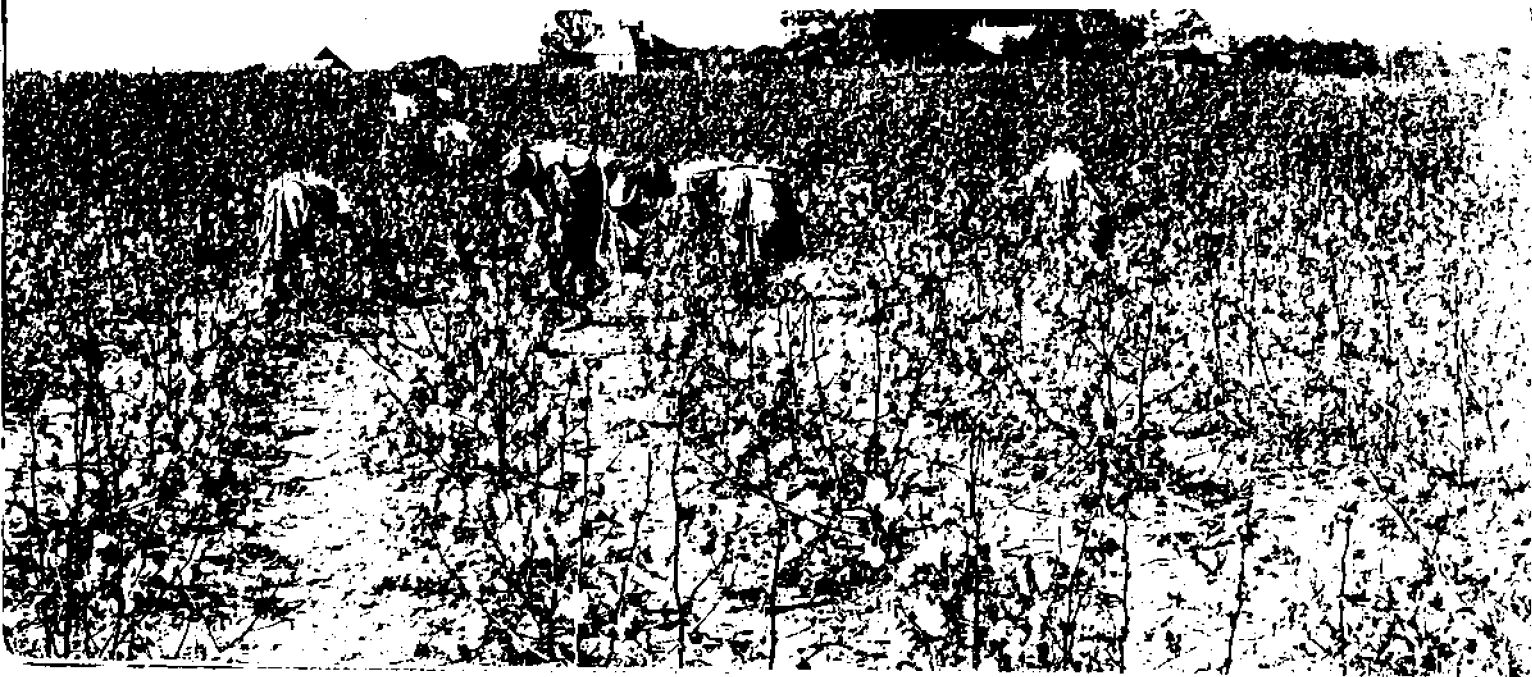

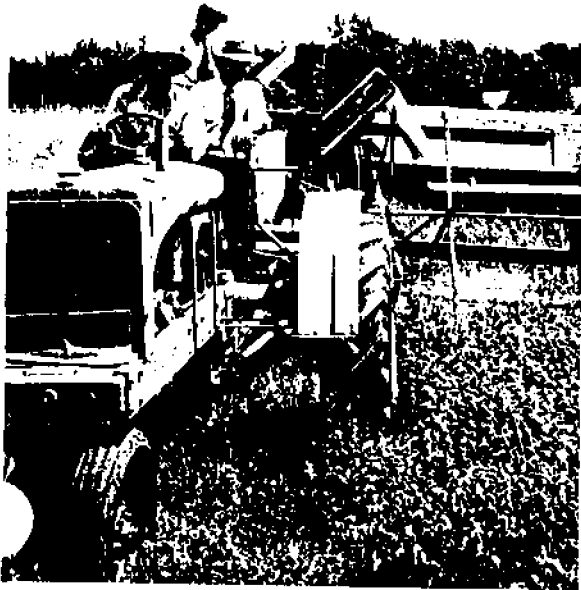

● *Harvesting scene*



● *Peaches in the orchard*

Twenty-three years ago Spartanburg started peach orchards. That original orchard continues productive. Today there are approximately 3,000,000 peach trees in the orchards of the county. In 1942 two million bushels were packed and shipped. It is estimated that the county grew two and a half million bushels that year. This one county produces 51% of all the peaches grown in South Carolina.

With a "stand" assured, the cotton grower "runs around," and follows that process by "dirtin'" his cotton - cultivating is lengthy. By the middle of July or the first of August the results are up to the weatherman and the boll weevil. In this region cotton picking begins between September 1st and 15th. And when picking starts, and you realize that each of billions of open bolls has to be reached by human fingers, you will not be surprised to find that everybody is doing it.

Which brings the story up to the picture of the girl under the big hat. She is a student of Converse College, one of scores who picked cotton in 1942, emptying her cotton from her laundry bag. She is "whewing," but she is going back to the patch. The Negro man behind her has on his shoulder the conventional cotton basket, filled with cotton other girls have picked and prevailed upon him to carry to the cotton pile in the field.



● *Peach grading - they must know their peaches*

● *Dairy cows in good pasture*



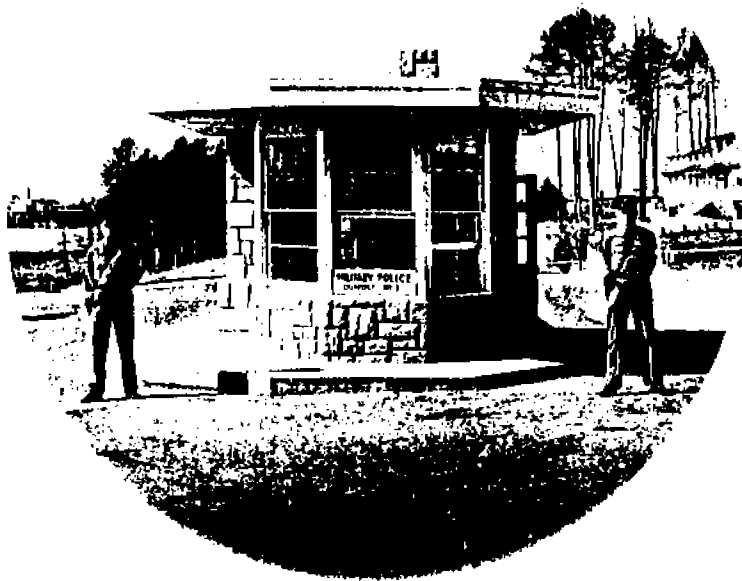

• Gate No. 2, Camp Croft

Two years, almost to the day, "Before Pearl Harbor," Camp Croft was converted from "Area B," a proposed site, to an army camp under construction. On February 10, 1941, it was the United States Army's Infantry Replacement Training Center, activated by order of Colonel L. A. Kunzig, the commanding officer.

Today Camp Croft (named in honor of the late Major General Edward Croft, of the United States Army, a South Carolinian) is one of the beautiful training camps of the country.

• Governor and Mrs. Jefferies meet a jeep



The cantonment area, of approximately 3,000 acres, lies within four and a half or five miles to the southeast of the city. The remainder of the more than 20,000 acre tract is largely given over to parade grounds, rifle and machine gun ranges, and additional training aid installation.

The camp was erected in a hill and dale country, now adding pleasing changes of terrain to the red-roofed military establishment sprawling over hills and valleys of a Piedmont area. In the area are three and perhaps more scenes of battles between the British and American forces taking place in the skirmishes leading up to the Battle of the Cowpens and the engagement on Kings Mountain. The graves of Revolutionary soldiers are in the camp area.

Camp Croft is a United States Army Infantry Replacement Training Center, to which men are sent from Induction Centers for their basic training, extending over a period of thirteen weeks. Between eighteen and twenty thousand men pass their training period at Camp Croft every three months. So it is true that Spartanburg is the host city of approximately 75,000 men annually.

Since Camp Croft was activated in February,



• Post exchange

1940, these distinguished officers have served as camp commanders: General L. A. Kunzig, General O. W. Griswold, General Alexander M. Patch, Jr., General G. R. Hubener, General Paul Ransom, General Charles P. Thompson, Jr., General D. S. Wilson, and Colonel F. D. Griffith.

Relations between Camp Croft and Spartanburg



● *Senator Byrnes takes a look*



● *A chapel at Croft*

have been cordial and void of unpleasant incidents throughout the years. At camp the exacting training routine is broken by definite schedules of recreational activities by the camp and by the several training battalion organizations. The Service Club, the Officers' Club and the various regimental headquarters are centers of entertainment wherein many Spartanburg people are from time to time guests.

In the city of Spartanburg are six U. S. O. Clubs, open throughout the week to soldiers and civilians, while many of the churches of the city maintain soldiers' club rooms and entertain weekly.

Camp Croft is presented in pictures on these pages. Gate No. 2, the Service Club gate, with "M. P.'s" on duty; Governor and Mrs. R. M. Jefferies of South Carolina, experiencing their first ride in a jeep, on a visit to the camp; the Post Exchange, near the Service Club; Senator James F. Byrnes takes a look at the targets on the rifle range; one of the chapels of the camp.



● *Soldiers at ease*

● *Trainees on parade*





● *Post Band No. 1*



● *Barracks building*

Here are other scenes at Camp Croft, Post Band No. 1 on the parade ground above, and a picture of one of the many barracks buildings. At the bottom of this page is the rifle range near White Stone.

On the opposite page, a hospital ward, an air view of the review of troops in honor of Colonel Kunzig, another of the targets and men firing on the rifle range, the cold storage plant, and the glimpse of a soldier party in the city.

In the building of Camp Croft, the government has invested more than \$10,000,000 in structures, water lines, sewerage disposal, a system of surfaced roads within the cantonment area, hospital, laundry, cold storage, highways, and railway terminals. The constructing quartermaster was Maj. Neil R. McKay. The availability of water and sewerage from the city's own system, the adequacy of electric power, and the convenience to rail and highway transportation were important factors in the location of Camp Croft at Spartanburg.

● *Targets on the rifle range*







● Residential  
Spartanburg

The City of Spartanburg, as one may conclude from the pages of this booklet, is not without its schools, colleges and churches. Also, the city has its interesting homes, its pleasing residential areas, its country club and golf courses, and parks within the city limits. An interesting recreational spot is Rainbow Lake, where a great basin of filtered water attracts many in the summer months.

The city's elevation is 875 feet above sea-level, and its proximity to high mountains, influencing its climate, gives it an average winter

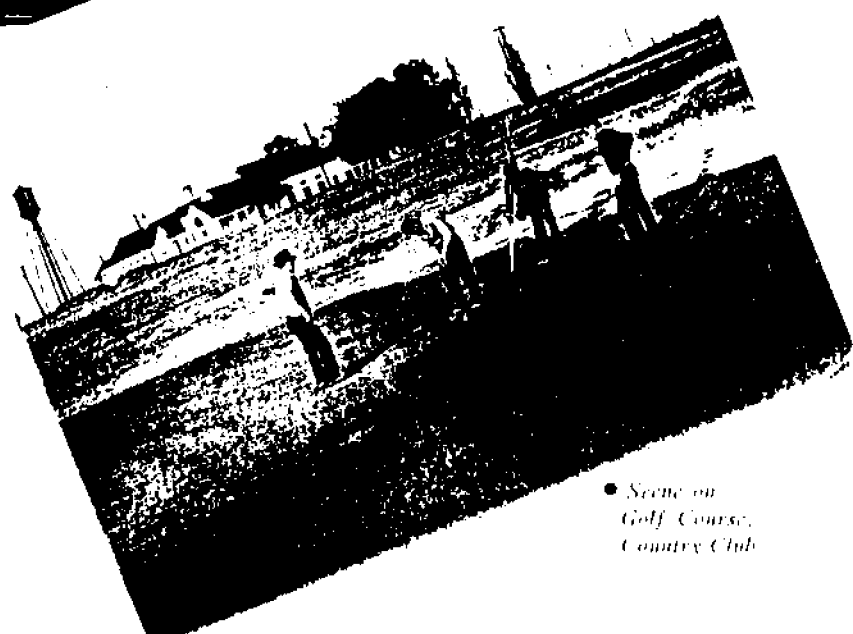

● Scene on  
Golf Course,  
Country Club

● Rainbow Lake



temperature of 42.3 degrees and a summer temperature of 70.7 degrees. Situated in a "soft water" region, the city's water appeals not only to industry but its softness is pleasing to the taste and comforting in the bath. The supply is from South Pacolet river, from a publicly owned plant, with a capacity of 13,000,000 gallons daily, now meeting a daily consumption of 9,500,000 gallons. Following a recent visit, a government inspector wrote the Water Works Board: "As regards operation of your water and sewage disposal plant, I am glad to say that I saw no deficiencies of sufficient moment to initiate any suggestions through any channels."

Hospitalization in Spartanburg is not overlooked. The General Hospital, county owned; the Tuberculosis Hospital, county owned; and the Mary Black Clinic, privately owned, meet

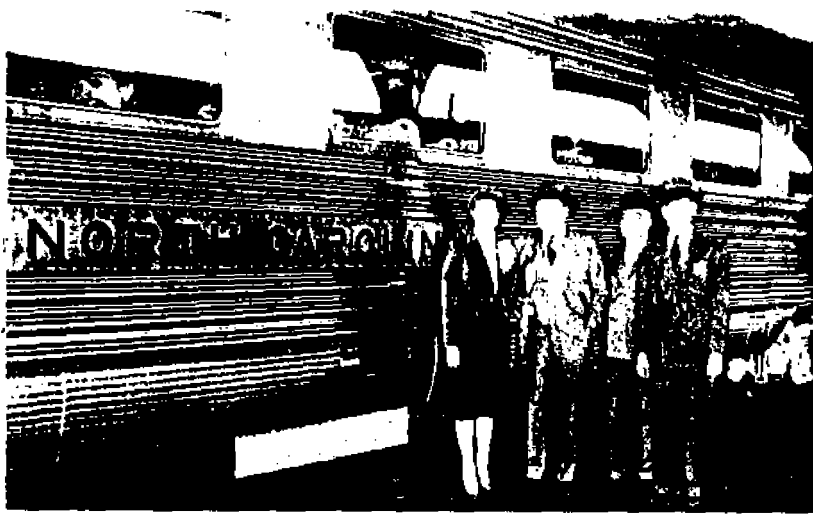

• Southern Railway's streamliner and Greyhound bus terminal

local demands, while for twenty-nine years the Spartanburg Baby Hospital has been maintained at Saluda, North Carolina, for the three months of the summer. A sick baby is the only requirement in entering a patient there. There is no institution just like it in the country.

In transportation and communication, the city offers no abills. It has the railroad, bus lines, air lines, telephone and telegraph lines that serve the nation. Highways in all directions—modern and maintained, as the traveling public knows, the South Carolina State Highway Department does that job.

Spartanburg is served by two daily newspapers and two weekly newspapers. The *Spartanburg Herald* (morning, established in 1890); the *Spartanburg Journal and Carolina Spartan* (afternoon, established in 1844). Both are members of the Associated Press.

In radio, Spartanburg leads with two stations, operated from one of the most modern radio studios in the Southeast. Station WSPA (950 on your dial) is a Columbia Broadcasting System affiliate. Station WORD (1100 on your dial) carries the service of the Blue Network. The United Press serves WSPA and the Associated Press News Service is broadcast over WORD.

So, with assurance that in Spartanburg there are available all those things industry might seek, or comfortable living might ask, the Chamber of Commerce invites your attention to the city's and the county's resources.

### Facts About Spartanburg and Spartanburg County

Airports	1
Altitude	875
Camp Croft, Acres, 20,000, personnel	20,000
Commercial Cameras	2
Churches	70
Civic Clubs	6
Golf Courses	2
Hospitals	4
Hotels	8
Industrial Workers	22,863
Motor Vehicle Registration	24,808
Newspapers (2 daily, 2 weekly)	4
Parks	2
Population: City (1940 Census)	32,249
Greater Spartanburg	53,951
County	127,733
Power Lines	3
Quick Freezing Plant	1
Radio Stations	2
Schools and Colleges	17
Temperature: Winter av., 42.3; summer av., 70.7	
Theatres	5
Transportation: Air Lines	1
Interstate Bus Lines	2
Federal Highway Routes	3
Railroads	4
Truck Lines, with Spartanburg Terminals	15
U. S. O. Clubs	6

• Radio center





## CHAPTER 2

### CLASSES OF AMMUNITION

#### Section I

### SMALL-ARMS AMMUNITION

#### 59. GENERAL.

a. Ammunition used in weapons whose bore is 0.60 inch or less (rifles, carbines, pistols, revolvers, and machine guns) and in shotguns is classed as small-arms ammunition.

b. Many types of cartridges are manufactured to the same profile. Consequently, cartridges of the same caliber although of different model may be very similar in appearance. Each type, and sometimes each model, as in the case of some tracer cartridges, has a characteristic colored bullet tip. Cartridges may be identified as to type, model, and caliber by marking on packing boxes and cartons.

c. The colors used on bullet tips to identify the type of cartridge are shown in figure 1 and described in paragraph 7 a (3).

#### 60. CARTRIDGES.

a. **General.** A round of small-arms ammunition is known as a cartridge. In general, it consists of a bullet, a propelling charge, a primer, and a cartridge case, all assembled into a unit assembly (figs. 24, 25, and 26).

b. **Bullet.** Bullets for service use have a metal core or slug which is covered with a gilding metal, or gilding-metal-clad steel jacket. In the case of caliber .45 bullets, copper-plated steel may be used instead of gilding metal for the jacket. Ball and tracer bullets have a lead alloy or common steel core or slug, whereas armor-piercing bullets have a hardened steel alloy core. Bullets have a flat or tapered base. A bullet having a tapered base is said to be "boat-tailed." A cannelure, or annular knurl, is rolled or cut into the jacket to provide a recess into which the cartridge case is crimped (figs. 27, 28, 29, and 30).

c. **Propelling charge.** There are two types of small-arms propellants generally used, the single-base nitrocellulose type and the double-base type. The double-base type is a mixture of nitrocellulose and nitroglycerin which burns more rapidly than the single-base type; it is used in shotgun shells, some caliber .45 rounds, and carbine ammunition. The weight of the charge and granulation of the powder are in accordance with specification requirements for velocity and pressure. The charge is assembled loosely in the cartridge case.

Classes of Ammunition

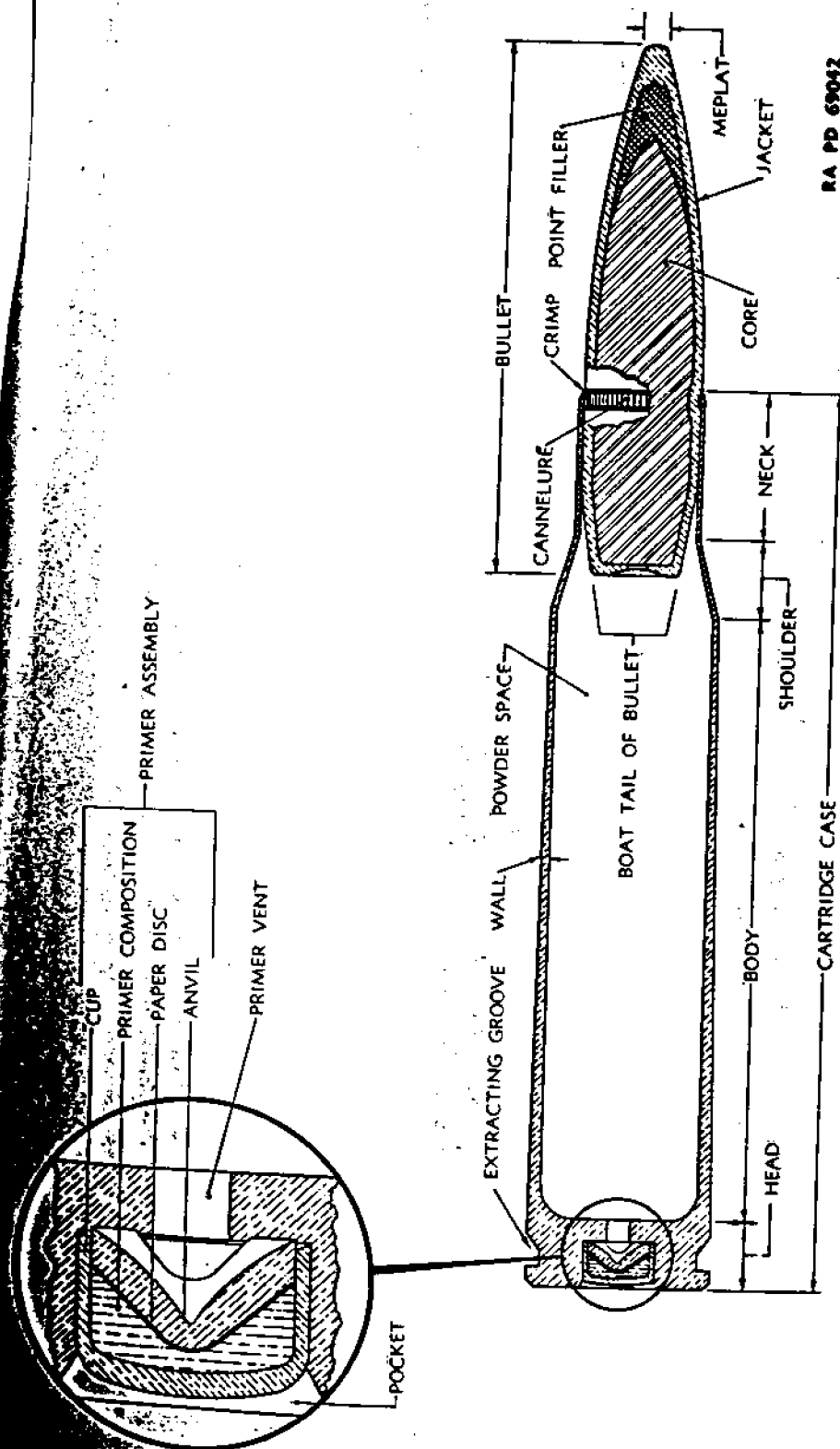

RA PD 69092

Figure 24 - Cartridge Terminology

Classes of Ammunition

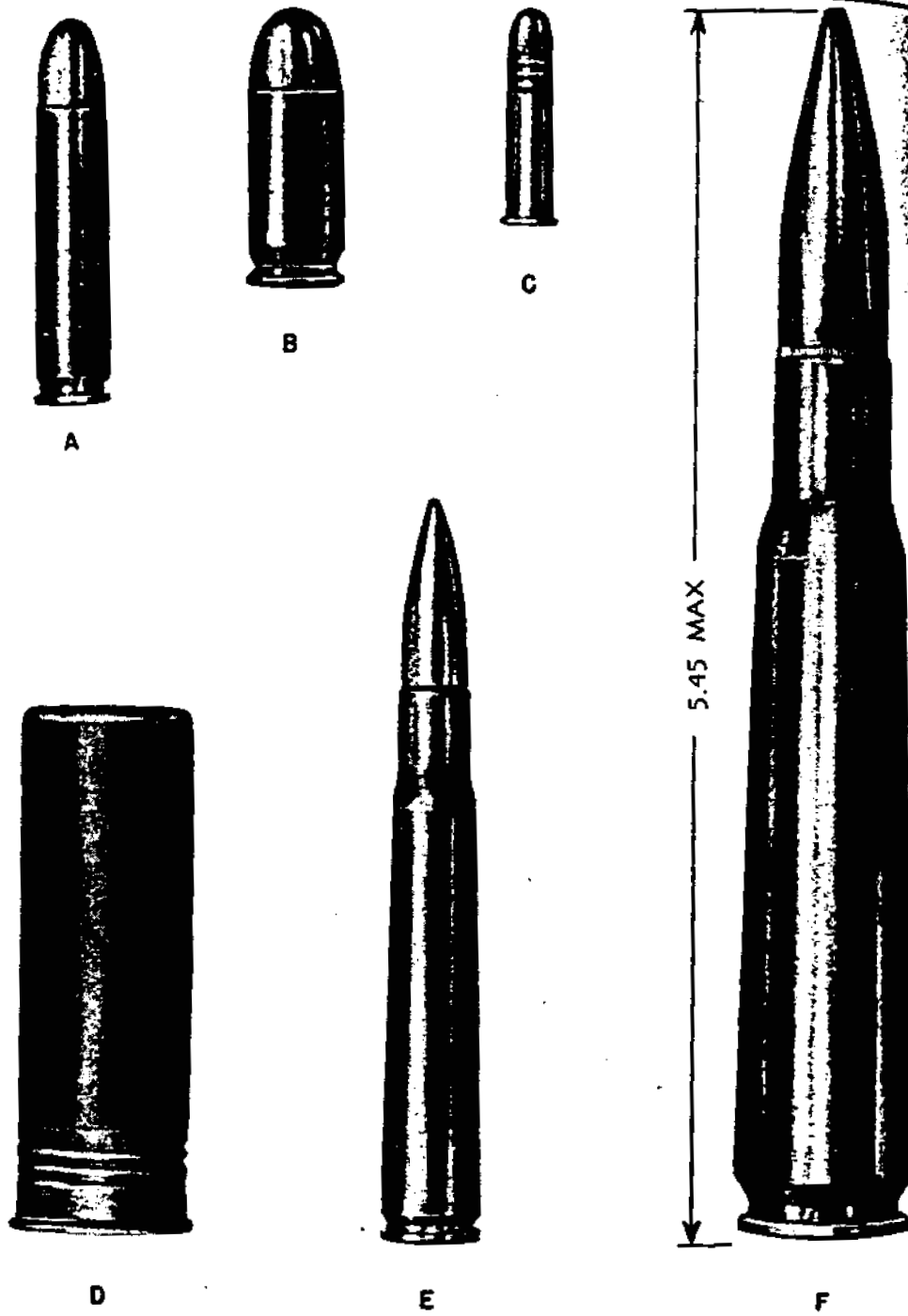

- A — CAL. .30 CARBINE BALL CARTRIDGE, M1
- B — CAL. .45 BALL CARTRIDGE, M1911
- C — CAL. .22 LONG RIFLE BALL CARTRIDGE
- D — 12-GAGE SHOTGUN SHELL
- E — CAL. .30 BALL CARTRIDGE, M2
- F — CAL. .50 BALL CARTRIDGE, M2

RA PD 4507B

Figure 25 — Types of Small-arms Ammunition

Classes of Ammunition

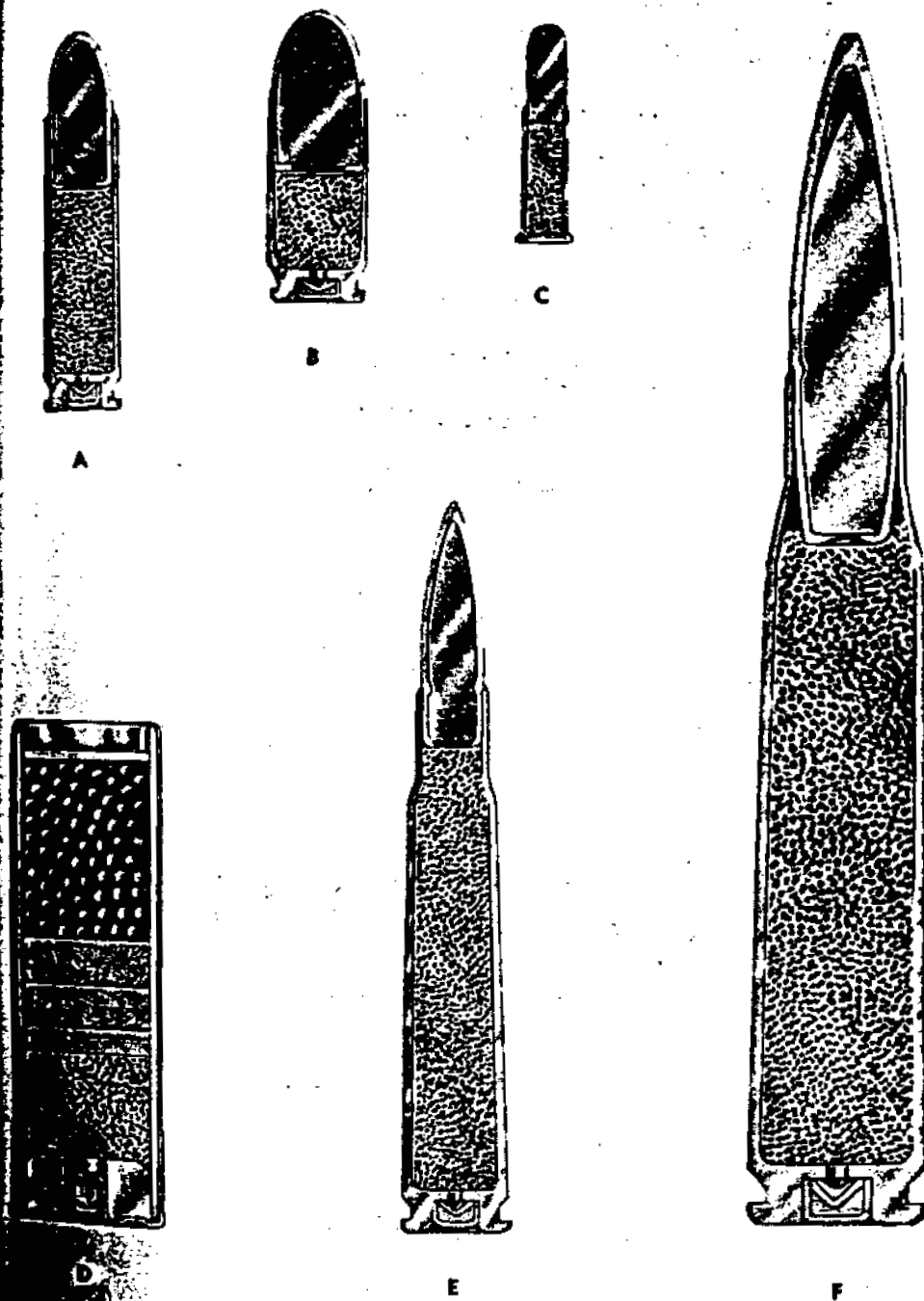

- A - CAL. .30 CARBINE BALL CARTRIDGE, M1
- B - CAL. .45 BALL CARTRIDGE, M1911
- C - CAL. .22 LONG RIFLE BALL CARTRIDGE
- D - 12-GAGE SHOTGUN SHELL
- E - CAL. .30 BALL CARTRIDGE, M2
- F - CAL. .50 BALL CARTRIDGE, M2

RA PD 89561A

Figure 26 - Types of Small-arms Ammunition - Cross Section

*Classes of Ammunition*

- A — BASE, FILLER-GILDING METAL
- B — COMPOSITION, IGNITER
- C — COMPOSITION, TRACER
- D — CORE-TUNGSTEN CHROME STEEL
- E — JACKET-GILDING METAL OR GILDING METAL CLAD STEEL
- F — POINT FILLER-LEAD "T" SHOT
- G — SLUG-LEAD WITH ANTIMONY
- H — BODY PLUG-LEAD SHOT
- I — INCENDIARY COMPOSITION
- J — STEEL BODY

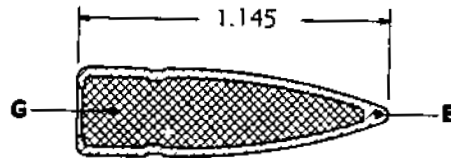

CAL. .30 BALL BULLET, M2

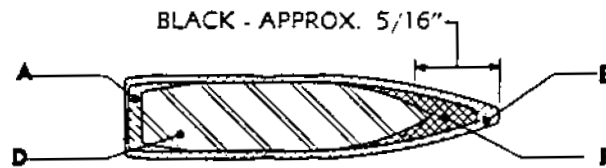

CAL. .30 ARMOR-PIERCING BULLET, M2

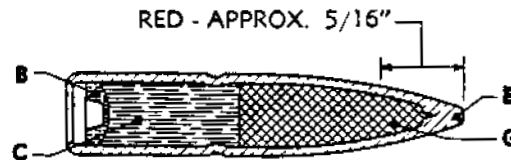

CAL. .30 TRACER BULLET, M1

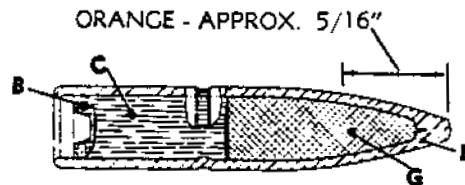

CAL. .30 TRACER BULLET, T10

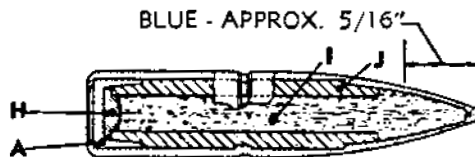

CAL. .30 INCENDIARY BULLET, M1

RA PD 4511C

*Figure 27 — Caliber .30 Bullets — Cross Section*

Classes of Ammunition

- |                                |                                     |
|--------------------------------|-------------------------------------|
| A — COMPOSITION, IGNITER       | G — POINT FILLER-LEAD WITH ANTIMONY |
| B — COMPOSITION, SUB-IGNITER   | H — SLUG, LEAD WITH ANTIMONY        |
| C — COMPOSITION, TRACER        | I — JACKET-GILDING METAL CLAD STEEL |
| D — CORE-STEEL                 | J — INCENDIARY MIXTURE              |
| E — CORE-TUNGSTEN CHROME STEEL | K — STEEL BODY                      |
| F — JACKET-GILDING METAL       |                                     |

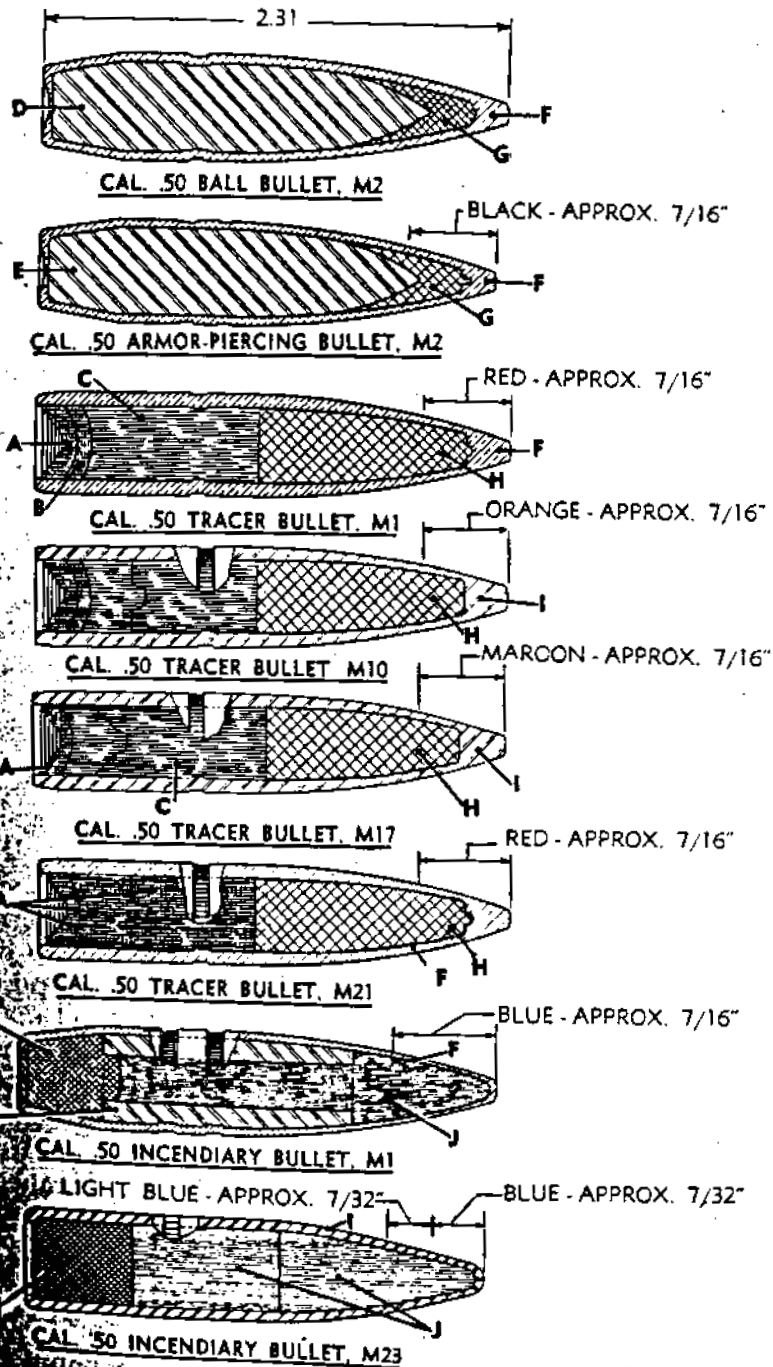

RA PD 89328A

Figure 28 — Caliber .50 Bullets — Cross Section

d. **Primer.** The primer consists of a brass or gilding-metal cup which contains a primer-composition pellet of sensitive explosive, a paper disk, and a brass anvil. A blow from the firing pin on the primer cup compresses the primer composition between the cup and the anvil, and causes the composition to explode. The holes or vents in the anvil allow the flame to pass through the primer vent in the cartridge case and ignite the propellant.

e. **Cartridge case.** The cartridge case is made of drawn brass or steel. It serves as a means whereby the other components—primer, propelling charge, and bullet—are assembled into a unit, the cartridge. Another of its functions is to expand and seal the chamber against the escape of gases to the rear when the cartridge is fired. This action is known as obturation. To make the cartridge waterproof and to keep the propelling charge dry, the primer is sealed in the primer seat and the bullet is sealed in the neck of the cartridge case by a thin film of lacquer or varnish at the time of manufacture. An extractor groove, turned in the head of the cartridge case, provides a means of removing the case from the chamber of the weapon.

61. **TYPES.** Small-arms cartridges are classified according to type as follows:

- |                                  |                    |
|----------------------------------|--------------------|
| Ball                             | Dummy              |
| Armor-piercing                   | High-pressure test |
| Armor-piercing-incendiary        | Gallery practice   |
| Armor-piercing-incendiary-tracer | Guard              |
| Incendiary                       | Subcaliber         |
| Tracer                           | Grenade            |
| Blank                            | Shot               |
|                                  | Shotgun shells     |

62. **BALL.** This type of cartridge, intended for use against personnel and light materiel targets, is the oldest service type. It is being replaced for combat purposes, however, by armor-piercing and other types. The term "ball," although no longer accurately describing the shape of the modern bullet, has been continued in use to designate that type of bullet and ammunition used for the same purposes as ammunition of very early design, the bullet of which was actually a ball (figs. 25 to 30). A special high grade of ball ammunition is manufactured each year for the National Matches of that year. The following year it may be used in preliminary firing for such matches. The second year, and thereafter, it is considered as standard service ammunition. The head of each of these cartridges is stamped "N.M." and with the year of manufacture.

63. **ARMOR-PIERCING.** This type of cartridge is intended for use against armored aircraft and vehicles, concrete shelters, and similar built-resisting targets. The bullet has a hardened steel alloy core. In addition, it may have a base filler and a point filler of a softer metal, such as gilding metal (figs. 27 and 28).

## Classes of Ammunition

- A-SLUG-LEAD ALLOY  
 B-JACKET-GILDING METAL  
 C-JACKET-COPPER-PLATED STEEL  
 D-IGNITER  
 E-TRACER COMPOSITION

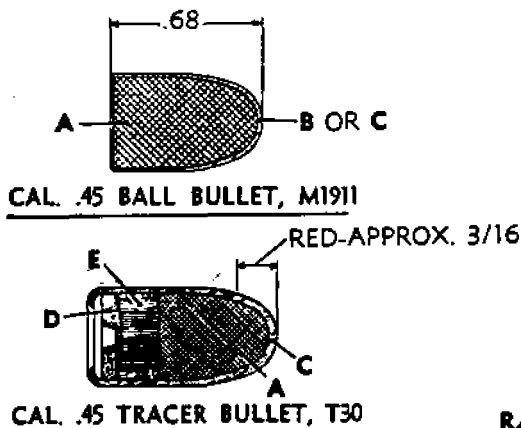

RA PD 89330A

Figure 29 - Caliber .45 Bullets - Cross Section

**64. ARMOR-PIERCING-INCENDIARY.** This type of cartridge is used in caliber .30 and caliber .50 weapons in lieu of using both armor-piercing and incendiary cartridges.

**65. ARMOR-PIERCING-INCENDIARY-TRACER.** This type of cartridge combines the features of armor-piercing, of incendiary, and of tracer cartridges and is intended to replace these cartridges.

**66. INCENDIARY.** This type of cartridge is similar to ball or armor-piercing ammunition in outward appearance. It is used for incendiary purposes against aircraft. It contains an incendiary composition, as a central bullet core, which ignites on impact with the target (figs. 27 and 28).

**67. TRACER.** This type of cartridge is intended for use with tracer types to show the gunner, by its trace, the path of the bullets, and assisting in correcting aim. It may also be used for incendiary purposes. The tracer element consists of a pressed inflammable material in the base of the bullet; this composition is ignited by the propelling charge when the cartridge is fired (figs. 27 through 30). For identification, the nose of the bullet is painted red, orange, or maroon.

**68. BLANK.** This type of cartridge (fig. 31) is distinguished by the absence of a bullet. It is used for simulated fire, training cavalry regiments, and firing salutes. It is also used in machine guns equipped



*Classes of Ammunition*

- A - SLUG-LEAD ALLOY
- B - JACKET-GILDING METAL
- C - IGNITER
- D - TRACER COMPOSITION
- E - JACKET-GILDING METAL CLAD STEEL

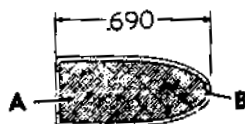

CAL. .30 CARBINE BALL BULLET, M1

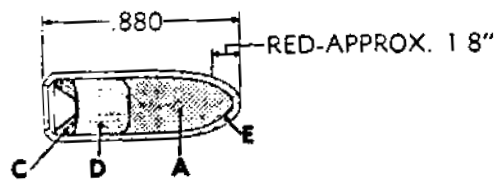

CAL. .30 CARBINE TRACER BULLET, M16

RA PD 89332A

**Figure 30 - Carbine Caliber .30 Bullets - Cross Section**

with blank-firing attachments in order to operate these weapons for instructional purposes. EC blank powder is used to produce the noise.

**69. DUMMY.** This type of cartridge (fig. 32) is used for practice in loading weapons, to detect flinching in firing weapons, and to simulate firing. The cartridge case of older lots of dummy ammunition is tin-coated. However, the present means of identification of dummy cartridges is by means of holes drilled through the side of the case and by the empty primer hole. The cartridges are completely inert but simulate service rounds in most details.

**70. HIGH-PRESSURE TEST.** This type of cartridge (fig. 33) is manufactured for use in proof firing of small arms. Since the propelling charge of this ammunition develops high pressures, these cartridges should never be used for any other purpose. When used for the purpose intended, all personnel should be protected by adequate cover. This ammunition is distinguished from other types by the tin coating of the cartridge case. In some older lots, the word "TEST" is stamped on the head of the case.

**71. GALLERY PRACTICE.** The present standard for gallery practice is the caliber .22 long rifle cartridge (figs. 25 and 26), a rim-fire cartridge of commercial manufacture. In the past a gallery practice cartridge, caliber .30 M1919 was used, but any available lots of this cartridge are reserved for guard purposes.

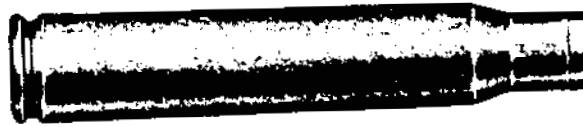
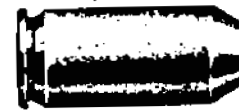
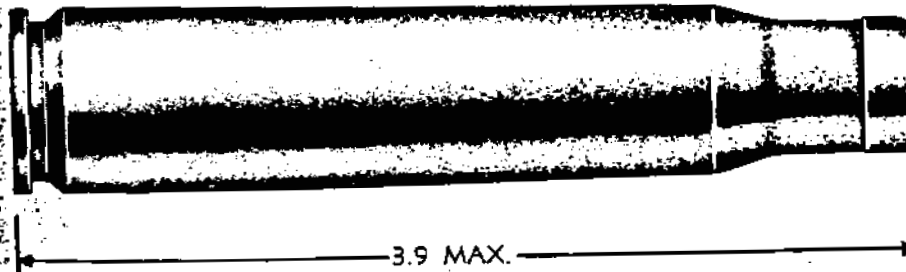
Classes of AmmunitionCAL. .30 BLANK CARTRIDGE, M1909CAL. .45  
BLANK CARTRIDGE, M9CAL. .50 BLANK CARTRIDGE, M1 (M40)

RA PD 89334A

*Figure 31 - Blank Cartridges*

**72. GUARD.** Guard cartridges consisted of a low-velocity charge and a round-nose lead bullet together with the cartridge case and primer. The guard cartridge M1 was formerly known as the gallery practice cartridge M1919 (par. 71). As in the case of the gallery practice cartridge, the use of the guard cartridge is being discontinued.

**73. SUBCALIBER.**

This type of cartridge (fig. 34) is fired from subcaliber tubes inserted in larger weapons. The subcaliber cartridge, caliber .30, M1925 is fired from a "Krag" type of subcaliber tube in 3-inch sea-land guns. This cartridge is identified by the extracting rim on the head of the case instead of the usual groove.

Other cartridges, specifically the standard caliber .22, caliber .30, and caliber .50 ball cartridges, are fired from subcaliber tubes in tank and antitank weapons.

**D-5a**

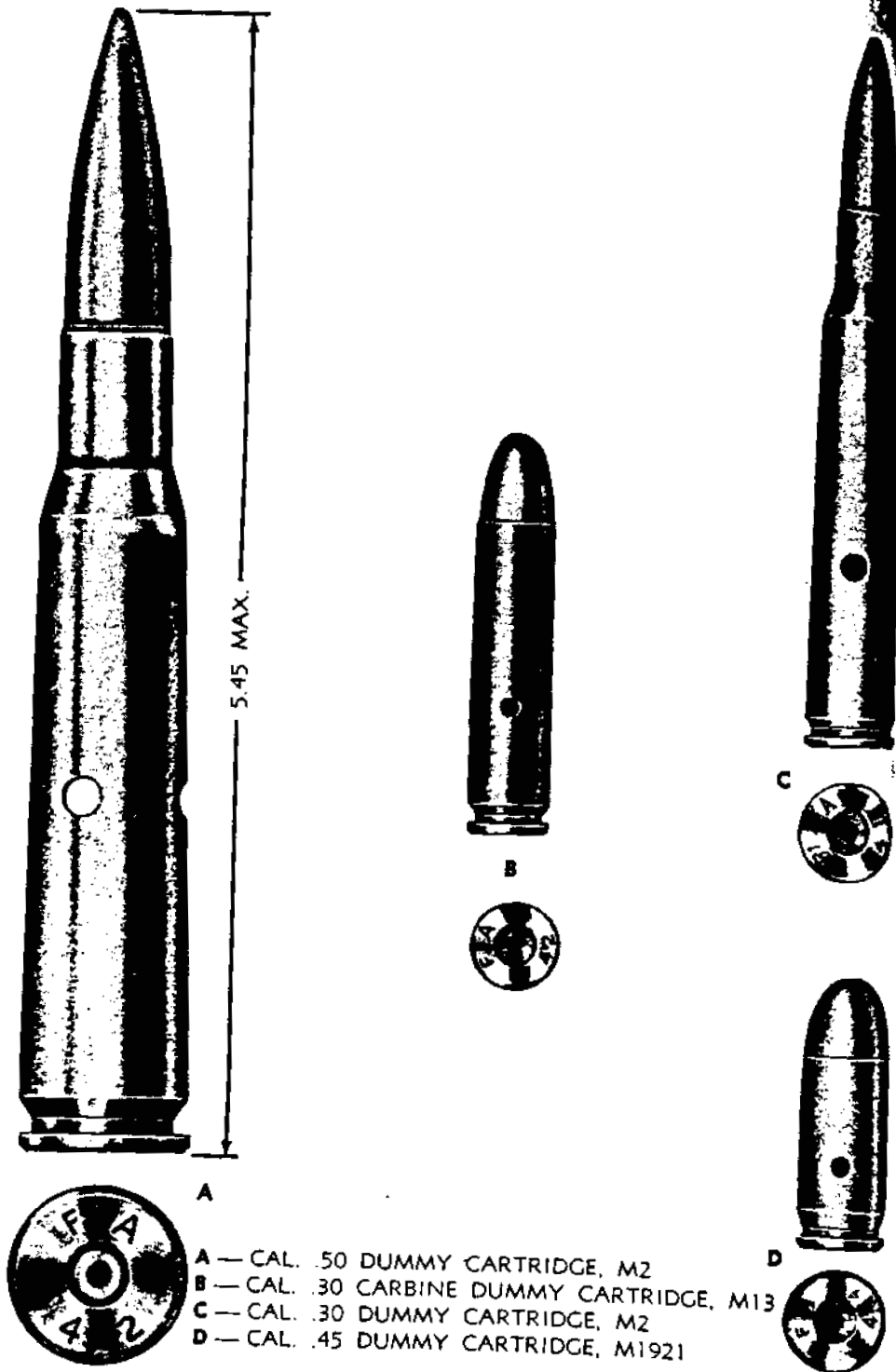

- A — CAL. .50 DUMMY CARTRIDGE, M2
- B — CAL. .30 CARBINE DUMMY CARTRIDGE, M13
- C — CAL. .30 DUMMY CARTRIDGE, M2
- D — CAL. .45 DUMMY CARTRIDGE, M1921

RA PD 89344A

Figure 32 — Dummy Cartridges

Classes of Ammunition

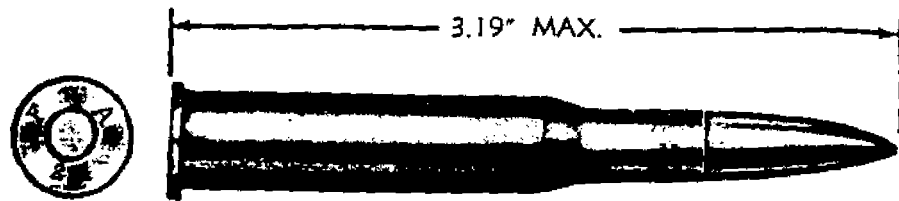

RA PD 23078A

Figure 34 - Caliber .30 Subcaliber Cartridge M1925



AUXILIARY GRENADE CARTRIDGE, M7

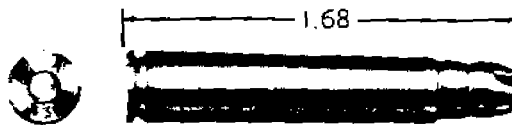

CAL. .30 CARBINE GRENADE CARTRIDGE, M6

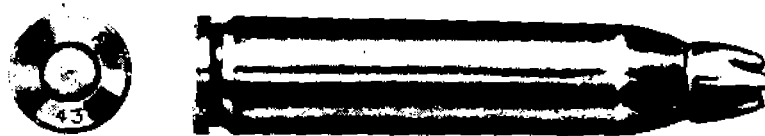

CAL. .30 RIFLE GRENADE CARTRIDGE, M3

RA PD 68318B

Figure 35 - Grenade Cartridges

74. **GRENADE.** Grenade cartridges (fig. 35) are special blank cartridges for use in propelling grenades from launchers attached to rifles or carbines. The rifle grenade and carbine grenade cartridges are distinguished by a rose-petal crimp at the mouth of the case. The auxiliary grenade cartridge M7 which contains a propellant but no primer is sometimes used in conjunction with the rifle or carbine grenade cartridge to give additional range.

75. **SHOT.** Shot cartridges of caliber .45 (fig. 36) are for use in pistols for hunting small game. Instead of a solid bullet, they contain No. 7½ chilled shot, which is also used in shotgun shell loadings. These cartridges are intended primarily for use by air force personnel as an aid in obtaining food.

76. **SHOTGUN SHELLS.** Shotgun shells (shot shells) of appropriate loads are procured commercially for use in 12-gage sporting-type and riot-type shotguns (fig. 37).

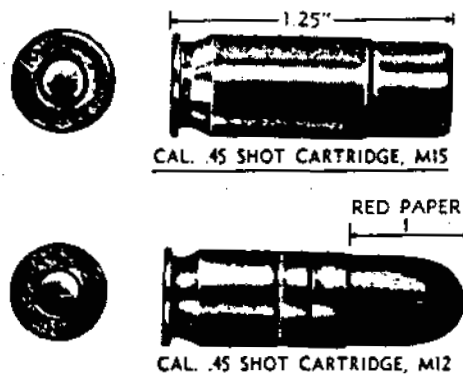
*Classes of Ammunition*

RA PD 89562A

**Figure 36 - Caliber .45 Shot Cartridges****77. GRADES.**

a. Current grades of existing lots of small-arms ammunition are established by the Chief of Ordnance in accordance with acceptance and surveillance tests, and are published in WD SB 9-AMM 4. Grade 3 indicates unserviceable ammunition, which will not be issued or used.

b. Small-arms ammunition which has been graded "For Training Use Only" will not be used in demonstrations or on training courses requiring this ammunition to be fired over the heads of participating troops.

**78. CARE AND PRECAUTIONS IN HANDLING.**

a. Small-arms ammunition is comparatively safe to handle. However, care must be taken to prevent ammunition boxes from becoming broken or damaged. Broken boxes must be repaired immediately, and careful attention given to the transfer of all markings to the new parts of the box. Metal liners should be air-tested and sealed if equipment for this work is available.

b. Ammunition boxes will not be opened until the ammunition is required for use. Ammunition removed from airtight containers, particularly in damp climates, may corrode and become unserviceable.

c. When cartridges are taken from their original packings for loading into clips or machine gun belts, the clips or belts should be tagged or marked so as to preserve the ammunition lot number, thereby preventing the ammunition from falling into grade 3 through loss of lot number (identity).

d. Ammunition should be carefully protected from mud, sand, dirt and water. If it gets wet or dirty, it should be wiped off at once.

Classes of Ammunition

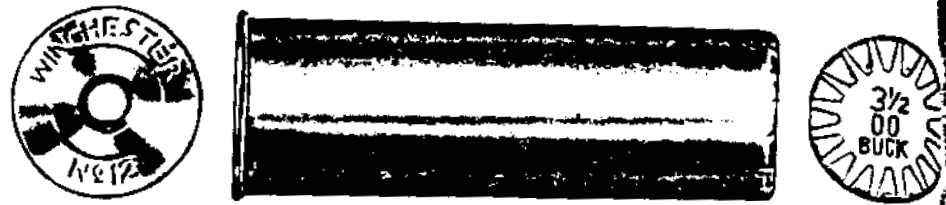

ALL BRASS NO. 00 BUCK 12-GAGE SHOTGUN SHELL, M19

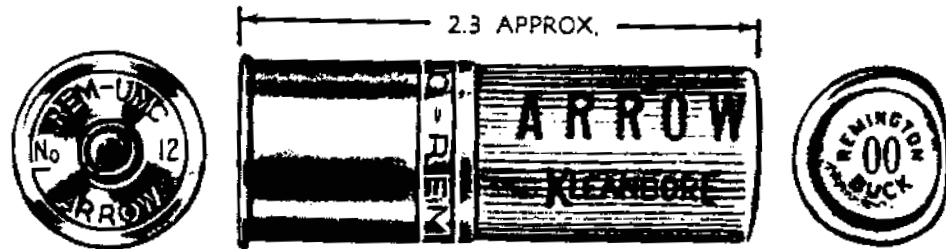

PAPER #00 BUCKSHOT 12-GAGE SHOTGUN SHELL



PAPER #7-1/2 CHILLED SHOT 12-GAGE SHOTGUN SHELL



PAPER #8 CHILLED SHOT AND TRACER 12-GAGE SHOTGUN SHELL

RA PD 23080A

Figure 37 - Shotgun Shells, 12-gage

### Classes of Ammunition

If light corrosion or verdigris forms on cartridges, it should be wiped off. However, cartridges should not be polished merely to make them look brighter or better.

e. Ammunition should not be exposed to the direct rays of the sun for any considerable length of time. This is likely to affect its firing qualities.

f. The use of oil or grease on cartridges is dangerous and is prohibited.

g. Cartridges that are dented, have loose bullets, or are otherwise defective should not be fired.

### 79. PRECAUTIONS IN FIRING.

a. Because a misfire cannot immediately be distinguished from a hangfire, it is unsafe to open the bolt of a rifle for at least 10 to 15 seconds after a misfire occurs. When the rifle M1 fails to fire, it should be recocked by means of the trigger guard and refired before the bolt is opened. When the rifle M1903 fails to fire, it should be recocked by drawing back the cocking piece and should be refired before the bolt is opened. The rifle M1917 cannot be recocked without opening the bolt; in case of misfire, wait a full minute before the bolt is opened. When the caliber .30 carbine fails to fire, pull the operating slide to the rear and release the operating rod. If the operating slide goes fully home, aim and fire. To avoid injury in case of hangfire, hold the hand so that no part of the palm or wrist can be struck by the operating slide in its rapid rearward movement.

b. Before firing, be sure that the bore of the weapon is free of any foreign matter such as cleaning patches, mud, sand, snow, etc. Firing a weapon with any obstruction in the bore will result in damage to the weapon and may result in injury to the firer.

c. No small-arms ammunition will be fired until it has been identified positively by ammunition lot number and grade, as published in the latest revision of WD SB 9-AMM 4.

d. For precautions in firing blank ammunition, see TM 9-1990.

e. Any serious malfunction of ammunition must be reported promptly to the ordnance officer under whose supervision the material is maintained and issued. As provided in AR 750-10, the ordnance officer will report such malfunction to the Chief of Ordnance. It is important, therefore, that all evidence be preserved. This includes the cartridge case, other cartridges from the same box, the weapon concerned, and all recoverable pieces—in short, everything that might determine the cause of the malfunction.

### 80. PACKING AND MARKING.

a. Packing. Dependent on its intended use, small-arms ammunition is packed in link and web belts, clips, or cartons (figs. 38

BOX AS RECEIVED

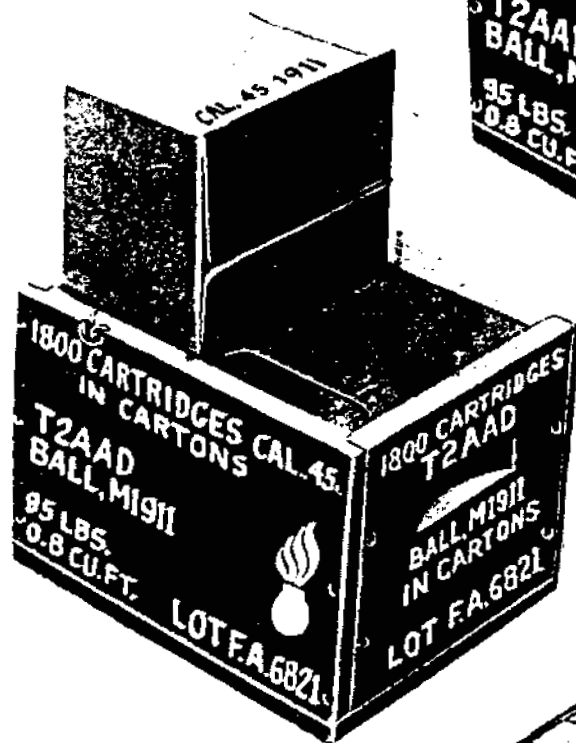
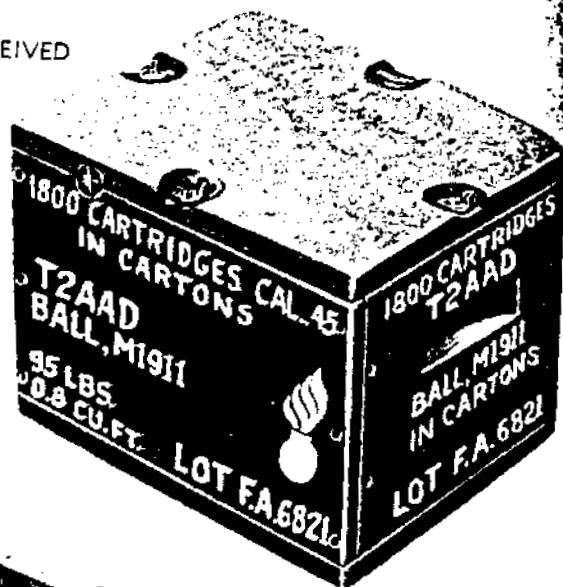

BOX WITH COVER REMOVED SHOWING WAXED CONTAINERS

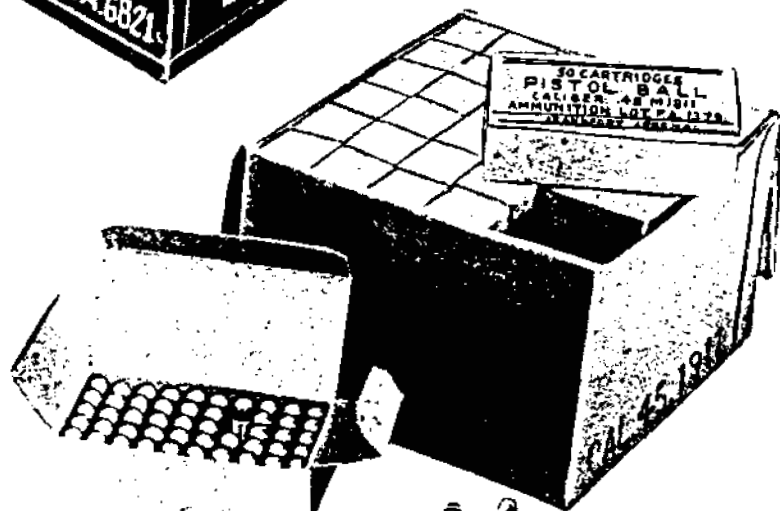

WAXED CONTAINER OPENED SHOWING CARTONS AND CONTENTS

RA PD 64466A

Figure 38 - Boxes Containing Carton-packed Ammunition in Waxed Containers



Classes of Ammunition



Figure 39 - Boxes Containing Carton-packed Ammunition in Metal Cans

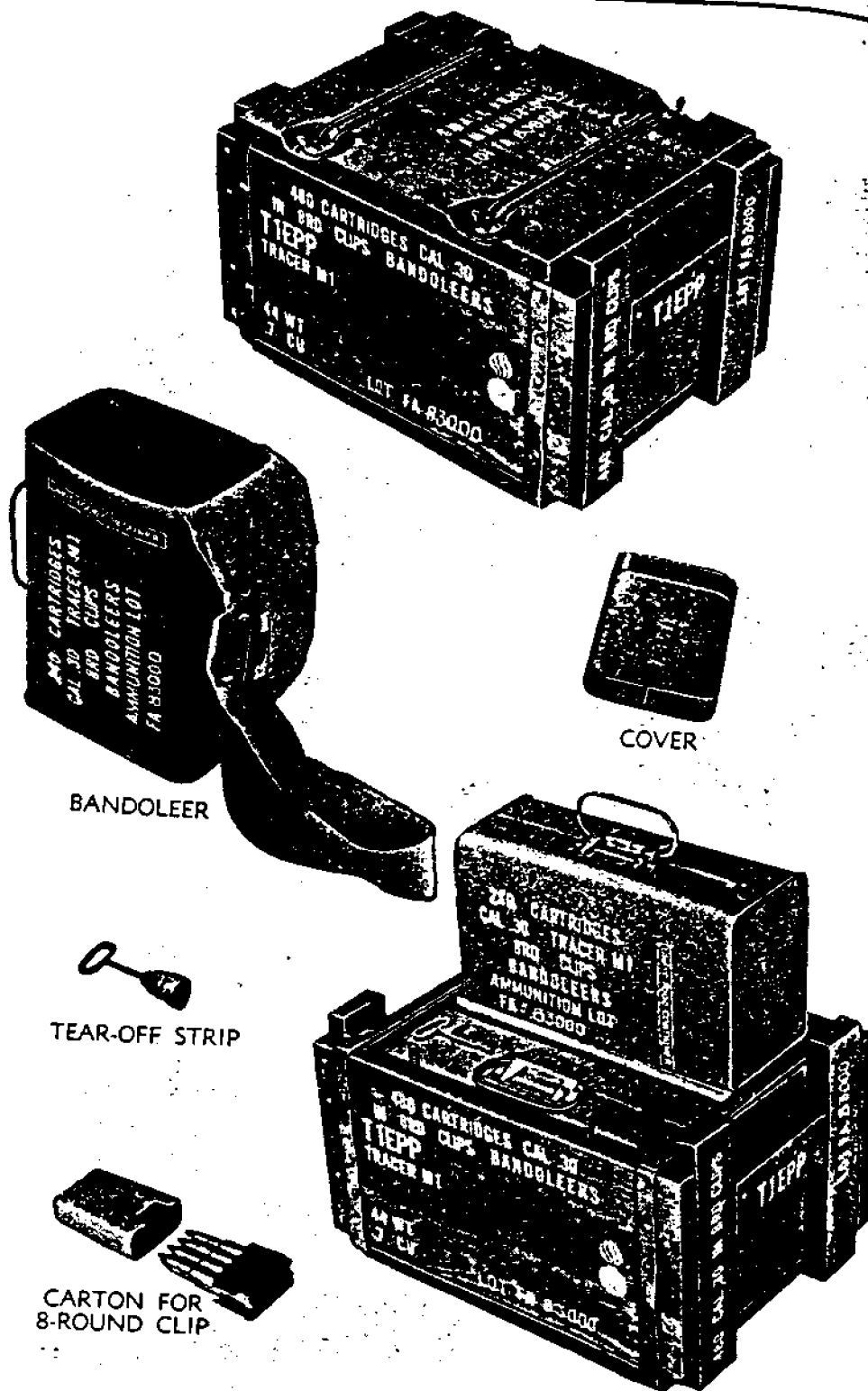

400 CARTRIDGES  
CAL 30 TRACER M1  
BANDOLEERS  
AMMUNITION LOT  
FA 83000

COVER

BANDOLEER

TEAR-OFF STRIP

CARTON FOR  
8-ROUND CLIP

RA PD 97725

Figure 40 - Boxes Containing 8-round Clipped Ammunition in Bandoleers in Metal Cans

Classes of Ammunition

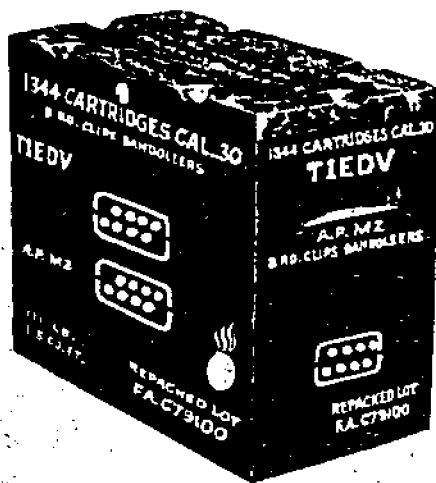

8-RD. CLIPPED



5-RD. CLIPPED

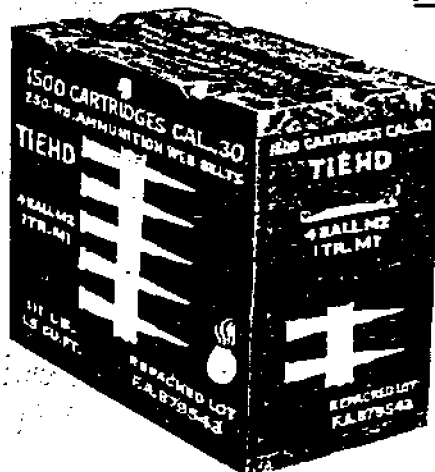

CAL. 30 BELTED

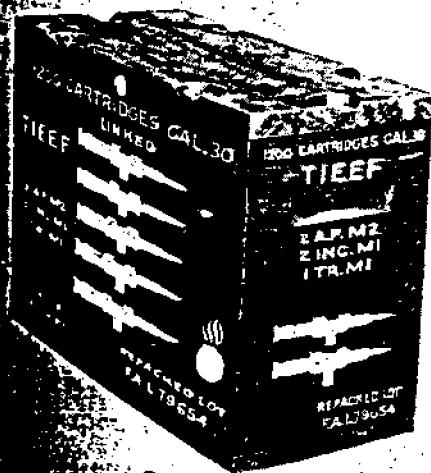

CAL. 30 LINKED

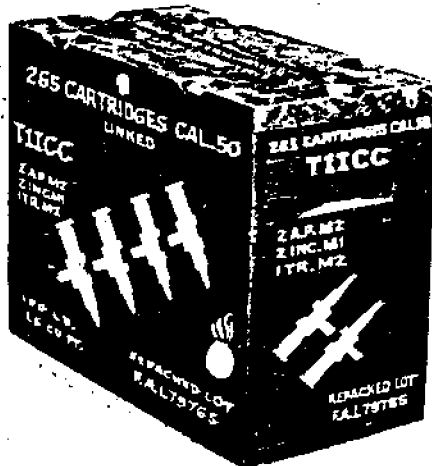

CAL. 50 LINKED

RA PD 15193B

Figure 41 - Packing Symbols on Small-arms Ammunition Boxes

Classes of Ammunition

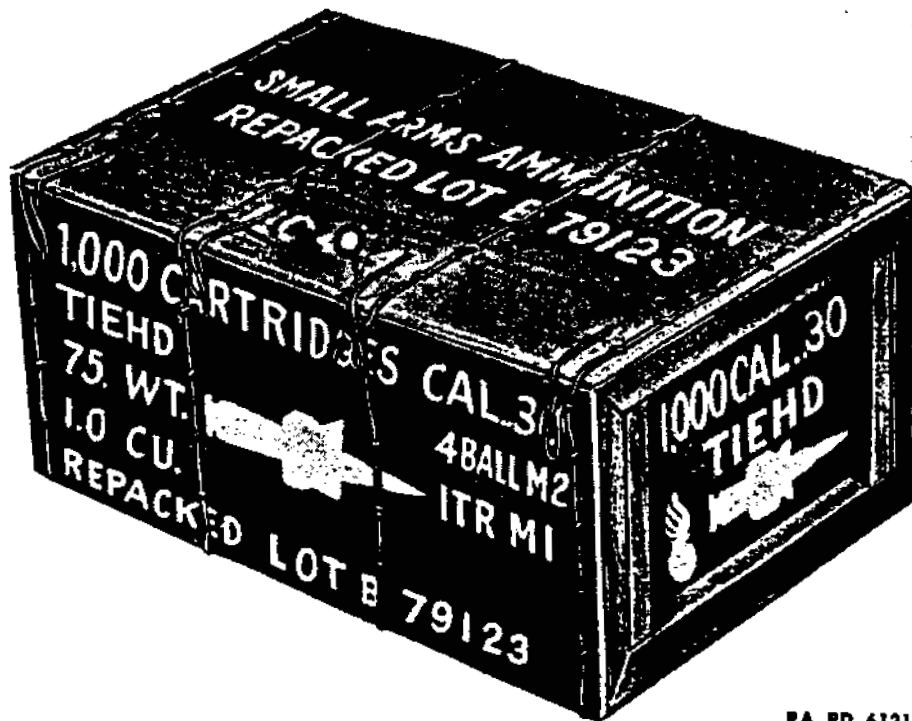

RA PD 612108

Figure 42 - Wire-bound Crate for Four Ammunition Boxes, Cal. .30, M1

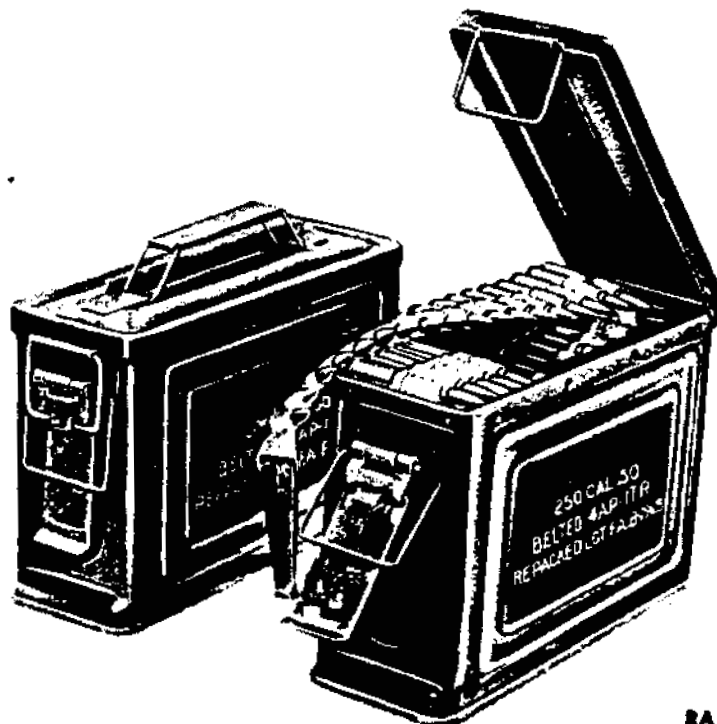

RA PD 683198

Figure 43 - Ammunition Box, Cal. .30, M1 (Steel)

*Classes of Ammunition*

---

through 43). For example, ammunition intended for use in the rifle M1 is packed in 8-round clips. For a detailed description of packing, see ORD 11 SNL's of the T group.

**b. Marking.**

(1) Small-arms packing boxes may be either stained brown with marking in yellow, or unstained with marking in black. Markings for shipment are covered in chapter 3, section IV, and in TM 9-1990.

(2) Instead of the lot number, a repacked lot number may be stenciled on packing boxes containing web belts and metallic link belts; the serial number of the repacked lot number is preceded by the letter "B" for belted ammunition, and "L" for linked cartridges.

(3) To provide a further means of quickly identifying type of packing, stenciled figure silhouettes are used on boxes and crates containing clipped, belted, and linked cartridges. These symbols indicate whether the ammunition is packed in rifle clips, web belts, or linked belts. The silhouettes are vertical for caliber .30 cartridges, and diagonal for caliber .50 cartridges (fig. 41). The absence of stenciled figure silhouettes on boxes indicates carton-packed ammunition (figs. 38 and 39).

(4) The expendable metal ammunition boxes are painted olive-drab with marking in yellow (fig. 43).

---

---

Section II  
**GRENADES**

**81. GENERAL DESCRIPTION.**

a. **Definition.** Grenades are small explosive or chemical missiles intended for use against an enemy at relatively short ranges.

b. **Basic types.** There are two basic types of grenades—those intended to be thrown by hand (figs. 11 and 44) and those intended to be projected from rifles or carbines equipped with suitable grenade launchers (figs. 12 and 45). By attaching a suitable adapter, some of the hand grenades may also be fired from rifles and carbines (figs. 46 and 47). Hand grenades provide the soldier with an auxiliary weapon, similar to a shell or bomb, to supplement his basic weapons. Rifle grenades are valuable not only for specialized use, such as against tanks, but also for covering the ranges between the maximum for hand grenades and the minimum for mortar shell. Special blank cartridges (fig. 35), packed with the rifle grenades, must be used in the weapon for projecting these grenades.

c. **General types.** Both hand and rifle grenades can be classified into three general types, namely: explosive, chemical, and practice or training.

---

*Classes of Ammunition*

---

(1) Explosive grenades are used primarily for antipersonnel (fragmentation or blast) or antitank effect. They may also be used as demolition agents.

(2) Chemical grenades are used for casualty, harassing, incendiary, screening, and signaling purposes. Some of them may also be used for training purposes and destruction.

(3) Practice and training grenades are used in training troops for combat.

d. **Fuzing.** Grenades thrown by hand are normally fitted with a delay-action fuze. For explosive hand grenades and the chemical M15 (bursting type) WP smoke hand grenade, this delay is set for approximately 4.5 seconds. Burning-type chemical hand grenades use a fuze with a delay of approximately 2 seconds. Rifle grenades are usually fitted with a base fuze that functions on impact.

## 82. EXPLOSIVE HAND GRENADES.

a. **Fragmentation type.** The Mk 2 is a typical fragmentation hand grenade (fig. 11 and A, fig. 44). This grenade is made of cast iron varying in thickness from  $\frac{1}{8}$  to  $\frac{1}{4}$  inch. The body is lemon-shaped, approximately  $2\frac{1}{4}$  inches in diameter and  $3\frac{1}{2}$  inches in length without the fuze. It contains an explosive charge which, upon detonation, breaks up the body of the grenade and fuze and projects the fragments outwards in all directions at high velocity. The body is grooved both horizontally and vertically. The fuze for this grenade has a primer, a combustible time-delay train, and a detonator. Attached to the fuze body is a safety lever held in place against the action of the striker spring by means of a safety pin. Just prior to throwing, the safety pin is removed. When the grenade is thrown the safety lever is pushed off by the striker, allowing the striker to impact against the primer. The primer ignites the time-delay train and, after 4 or 5 seconds, this delay train causes the detonator to explode. This, in turn, causes the explosive filler in the grenade to detonate, thereby fragmenting the grenade. Fragments may fly over 200 yards.

b. **Offensive type.** The offensive grenade (fig. 11 and C, fig. 44) is intended to have an antipersonnel effect over a small area. It contains more explosive than the fragmentation-type grenade, approximately  $\frac{1}{2}$  pound of pressed TNT, and, therefore, is more useful as a demolition agent. No fragmentation effect is obtained.

## 83. CHEMICAL HAND GRENADES.

a. **Burning type.** The standard container for this type of grenade (fig. 11 and D, fig. 44) is a cylindrical steel can  $2\frac{3}{8}$  inches in diameter and  $4\frac{1}{4}$  inches high. The fuze for these grenades is similar to the fuze used in the Mk 2 fragmentation grenade, except that

Classes of Ammunition

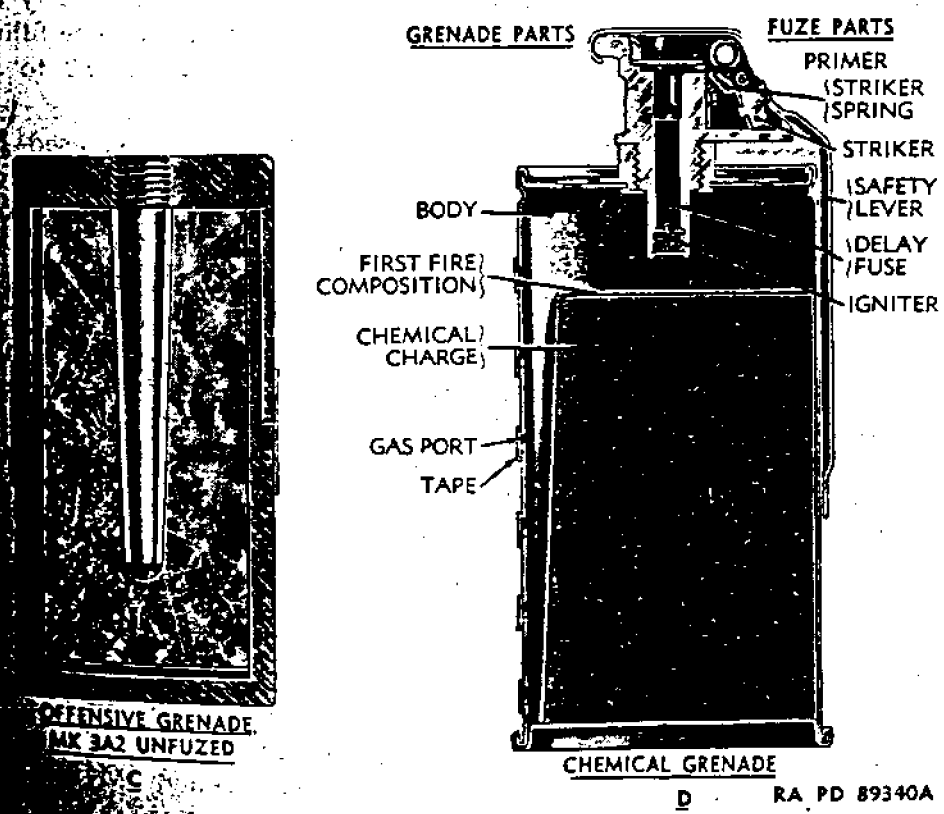
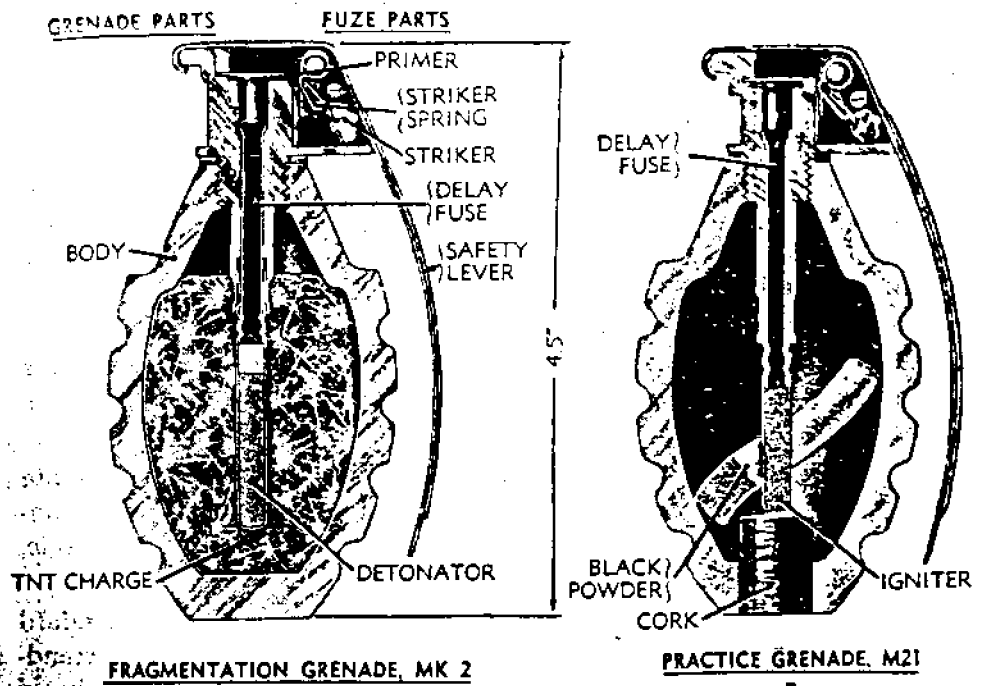

Figure 44 - Hand Grenades - Cross Section



*Classes of Ammunition*

has an igniter instead of a detonator, and has a short delay time of 2 seconds. Grenades of this type have waterproof, adhesive-tape covered, smoke emission holes in the top, sides, or bottom. These grenades are described briefly as follows:

(1) **CN-DM IRRITANT HAND GRENADE.** The products of combustion of the filler in this grenade have a harassing effect. Its principal use is in the control of civil disturbances. The burning time is 20 to 60 seconds. The filler is a composition of tear gas, vomit gas, and smokeless powder.

(2) **CN TEAR HAND GRENADE.** This grenade is identical with the CN-DM grenade except that it has a tear gas filler. Principal uses are in control of civil disturbances, and training in use of the gas mask.

(3) **HC SMOKE GRENADE.** This is an Army-Navy standard white smoke grenade, used for signaling and screening purposes. The container is standard except that there are no emission holes in the side. The burning time is 2 to 2½ minutes.

(4) **TH INCENDIARY GRENADE.** This is an Army-Navy standard munition for setting fire to enemy materiel. The container is standard except that there are no emission holes in the side. Clamps of steel strapping, which fit around the body of the grenade, may be used to nail the grenade against an object to be burned. The filling is thermate, which burns at approximately 4,330° F for 30 to 35 seconds.

(5) **COLORED SMOKE GRENADE M16.** This grenade, used for ground-air and ground-ground signaling purposes is made in the following colors: green, yellow, red, and violet. It is of standard construction and burns for approximately 2 minutes.

(6) **COLORED SMOKE GRENADE M18.** This grenade, available in red, green, yellow, and violet, is also used for signaling purposes. The container has emission holes in the top, and a single hole at the bottom. A tapered hole extends through the center of the grenade from the bottom emission hole to the fuze. The starter mixture lines the tapered cavity. The grenade produces a heavy smoke for approximately 1 minute.

(7) **RED SMOKE GRENADE AN-M3.** This grenade is an Army-Navy air forces official distress signal. It is the standard metal grenade except that the fuze lever is shortened and the body is covered with a metal jacket to which are attached three metal strips which may be bent out from the jacket to keep the grenade from sinking into snow or soft ground. Burning time is 2 to 2½ minutes.

**b. Bursting type.** There is only one standard chemical grenade of this type and it is known as the WP smoke grenade M15. This grenade has a drawn-steel cylindrical body similar in size to the burning-type chemical hand grenades, and is filled with white phos-

Classes of Ammunition

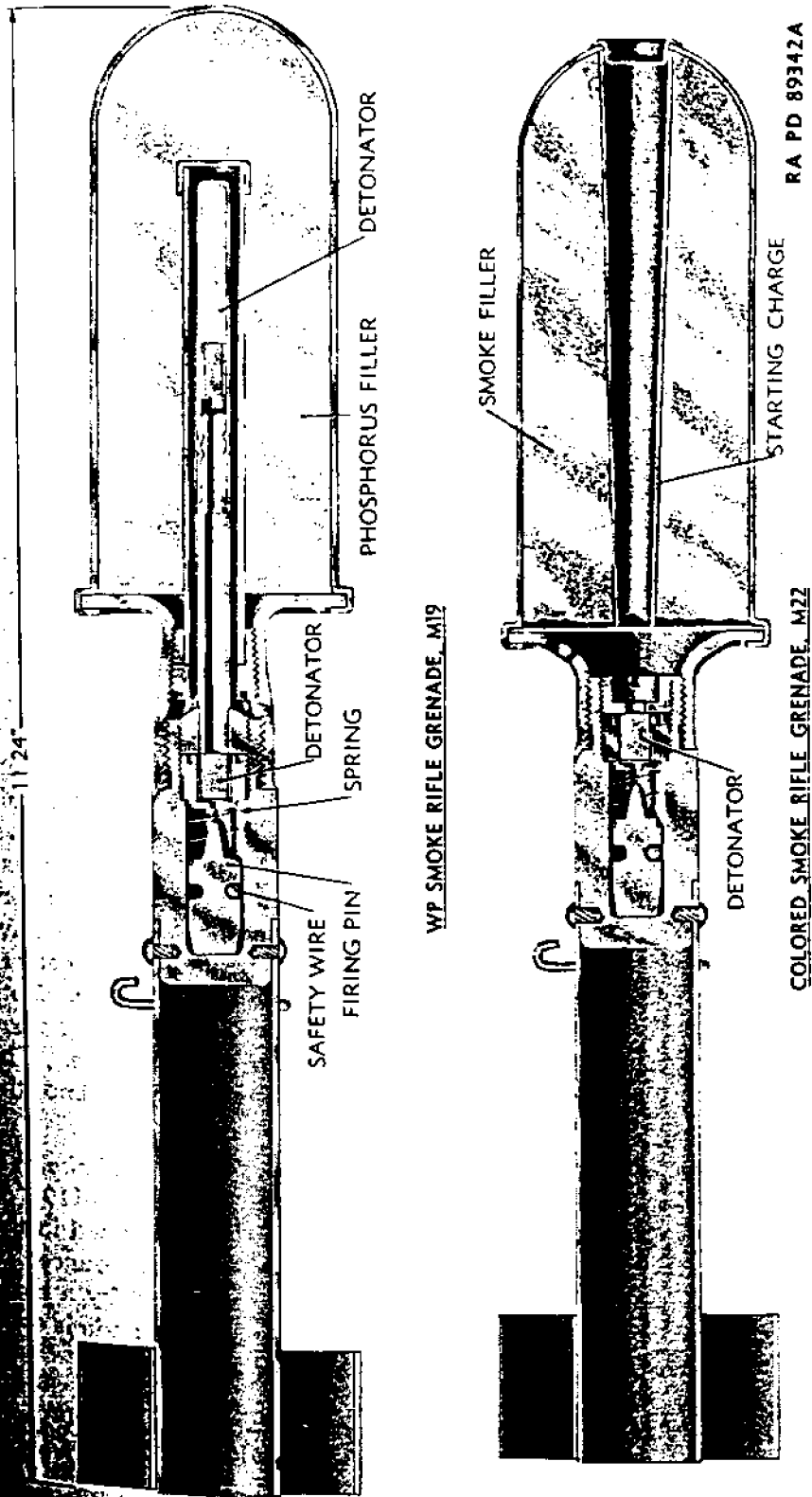

Figure 45 — Smoke Rifle Grenades — Cross Section

*Classes of Ammunition*

phorus. The detonating fuze used in this grenade causes it to split open and project burning particles of phosphorus over a radius of about 15 yards. This produces a dense white smoke screen and will cause casualties by burning.

**84. PRACTICE AND TRAINING HAND GRENADES.** This type of grenade (fig. 11 and B, fig. 44) is used in training. They may be inert (training), or loaded with a charge of black powder contained in a cloth tube (practice). In this case the charge is inserted into the filling hole, which is closed with a cork.

**85. EXPLOSIVE RIFLE GRENADES.** Antitank type: A typical antitank rifle grenade, the M9A1 (fig. 12) consists of a sheet-steel body, cone, and ogive assembly to which is attached a simple base-detonating fuze and a stabilizer and fin assembly. The head of the grenade contains a 4-ounce cast-pentolite, shaped charge for blasting holes in the target. At the same time detonation of the main charge causes fragmentation of the body in a lateral direction. The grenade is intended primarily for use against armored vehicles. It has been found to be most effective against enemy personnel when it is fired at a high angle of elevation (45°).

**86. CHEMICAL RIFLE GRENADES.**

a. **Burning type.** These grenades consist of a deep-drawn, thin-walled steel body with hemispherical ogive and body union assembly to which is attached a simple base fuze and a stabilizer and fin assembly (B, fig. 30). This type of grenade is available with approximately 10¾ ounces of HC white smoke or 6½ ounces of standard colored smoke fillings. Both HC and colored smoke grenades have five sealed smoke emission holes in the body union. The colored smoke grenades also have a smoke emission hole in the ogive. Both of these types of chemical rifle grenades commence burning upon impact, due to the action of the base initiating type of fuze. The HC grenade is intended primarily for screening purposes and the colored smoke grenades for signaling.

b. **Bursting type.** This grenade is the counterpart of the WP smoke hand grenade M15. The WP smoke rifle grenade M19 (A, fig. 45) has a stabilizer and fin assembly identical to that used in the antitank grenade M9A1. It contains approximately 8.5 ounces of white phosphorus and is equipped with a burster actuated by a base-detonating fuze. The spontaneously combustible WP grenade is scattered upon impact.

**87. PRACTICE AND TRAINING RIFLE GRENADE.** There is at present only one standard practice rifle grenade, the M11A3 (fig. 12). This grenade is used only in training and simulates the flight and

Classes of Ammunition

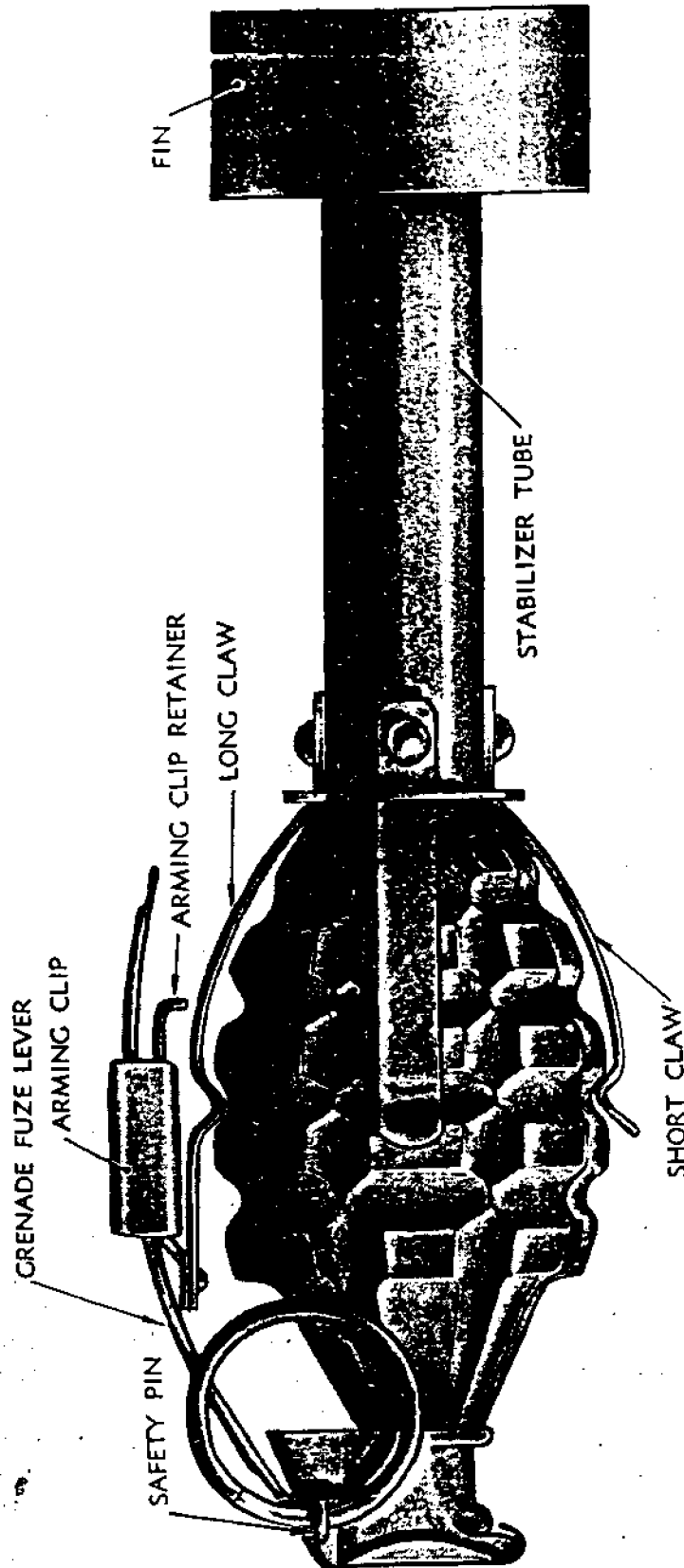

RA PD 68355

Figure 46 — Fragmentation Grenade Projection Adapter M1

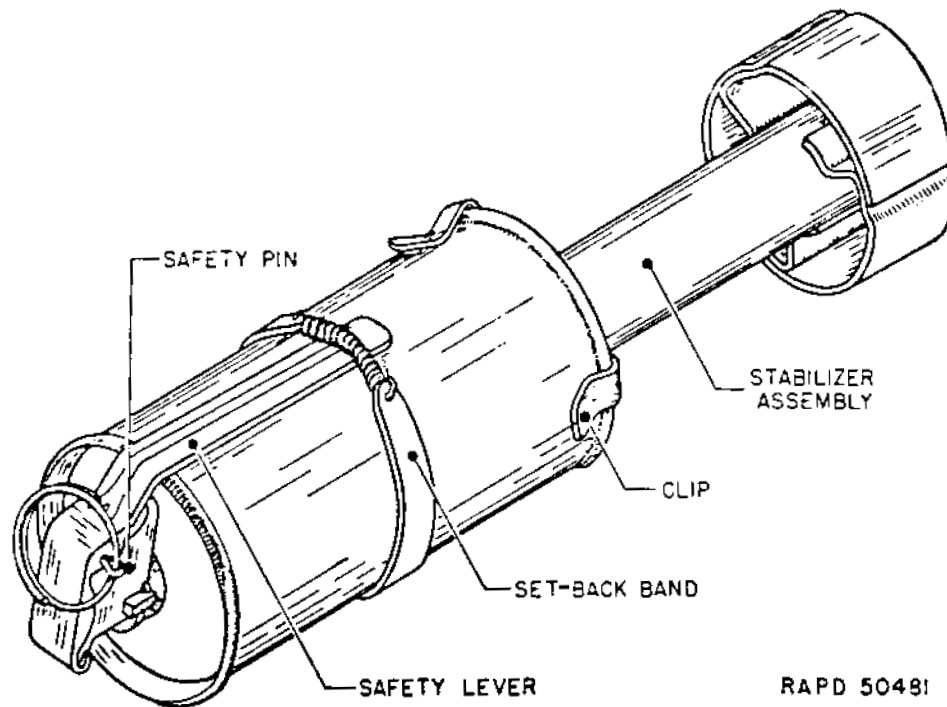

Figure 47 — Chemical Grenade Projection Adapter M2

action of the AT grenade M9A1. Being completely inert, this grenade is painted black. For repeated use, it is issued with additional replacement fins and ogives.

**88. GRENADE PROJECTION ADAPTERS.**

a. The grenade projection adapter (fig. 46) assembled to a fragmentation hand grenade Mk 2 permits this hand grenade to be used as a rifle grenade. After removal of the grenade safety pin before firing, the safety lever is held in position by the arming clip. Upon firing the grenade from a launcher-equipped rifle or carbine, the arming clip frees itself from the arming clip retainer, thereby releasing the grenade safety lever and initiating the 5-second fuze. Grenade cartridges are packed in each adapter packing box.

b. The chemical grenade-projection adapter (fig. 47) is intended for use with the chemical hand grenades. It consists of a stabilizer tube, which has a base plate and a three-pronged clip on one end and on the other end, a standard fin similar to that on the grenade M9A1, and a metal setback band which fits around the grenade, over the safety lever. Upon firing the grenade from a launcher-equipped rifle or carbine, the setback band moves to the rear, thereby releasing the grenade safety lever and initiating the 2-second fuze. Grenade cartridges are packed in each adapter cartridge packing box.

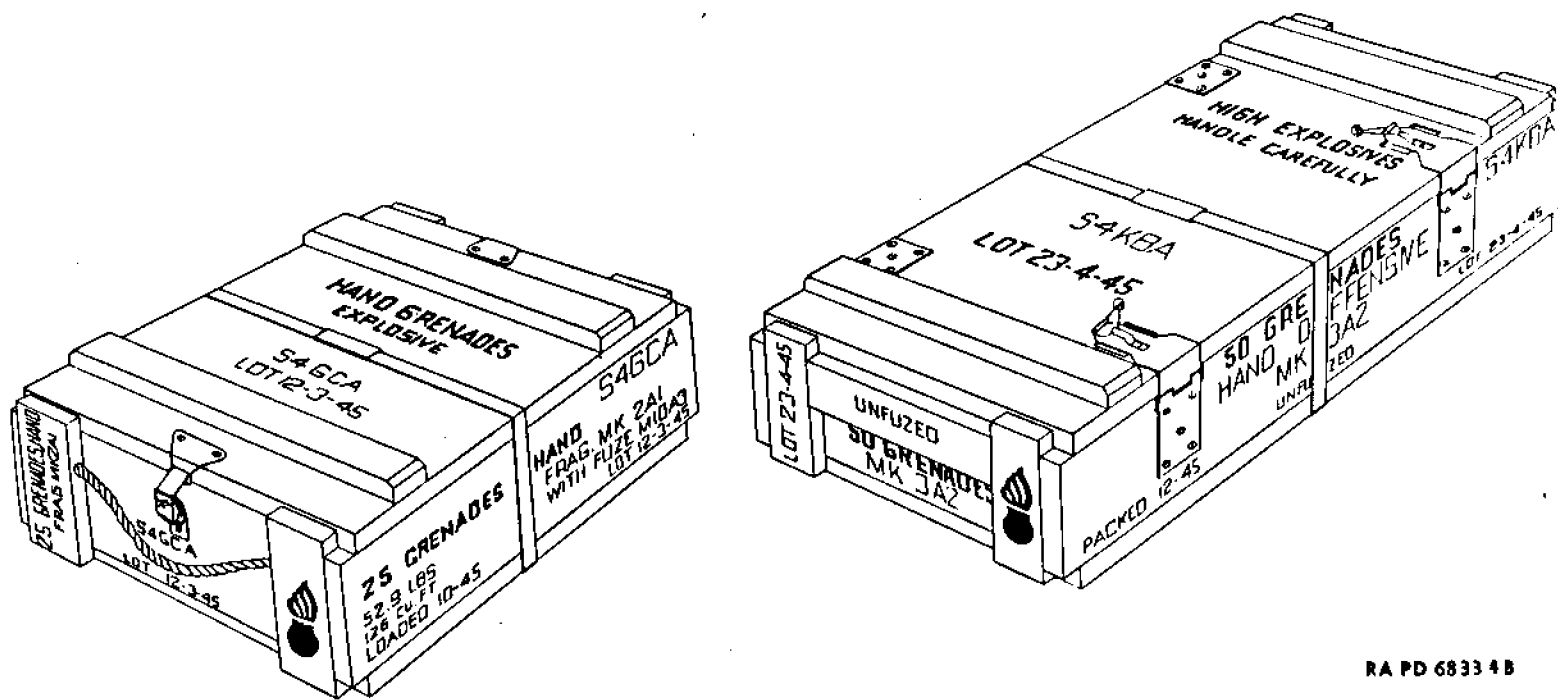

RA PD 6833 4B

Figure 48 – Typical Packing of Hand Grenades

83

D-5b

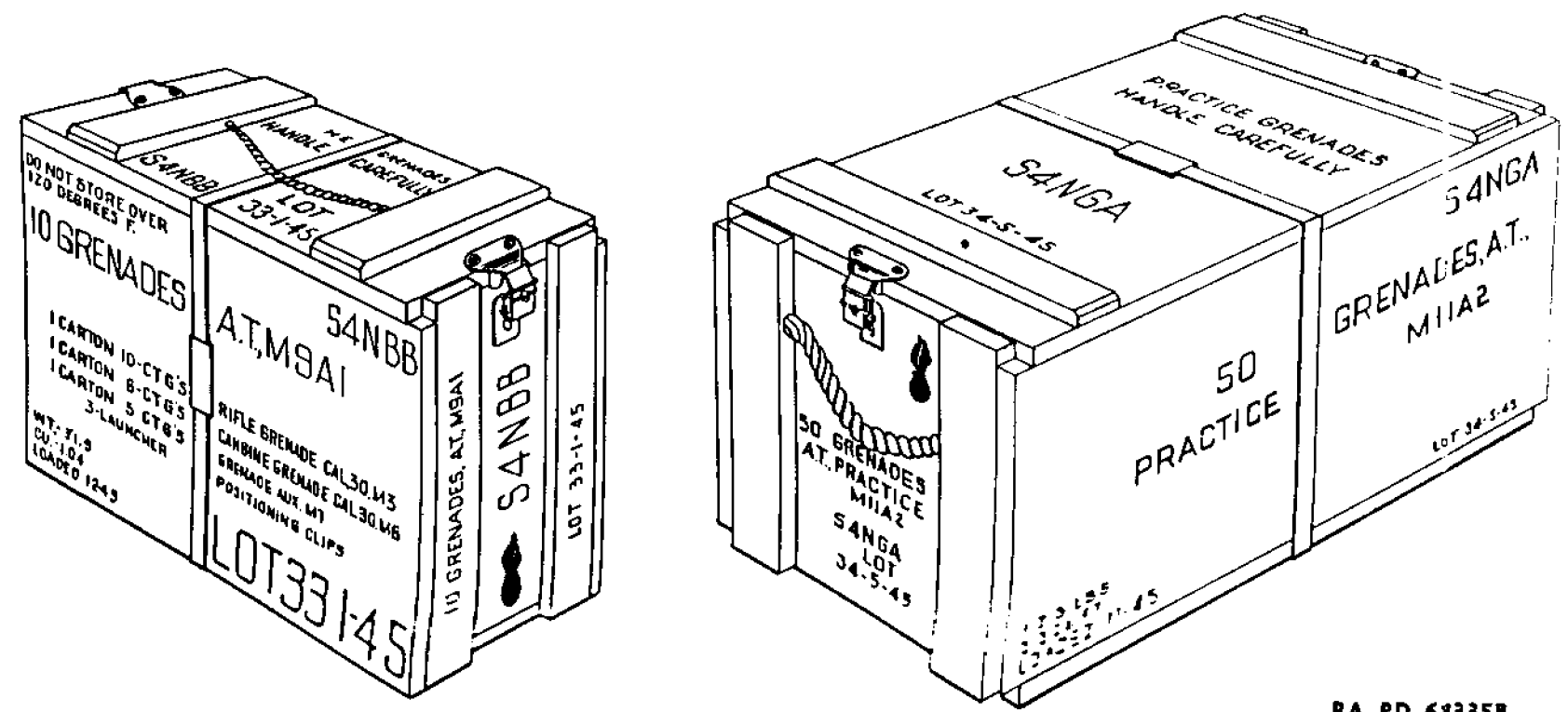

RA PD 68335B

Figure 49 - Typical Packing of Rifle Grenades

D-5b

*Classes of Ammunition***89. CARE AND PRECAUTIONS IN HANDLING.**

a. **Care.** Information concerning the care to be exercised in handling grenades will be found in chapter 3 of this manual and pertinent Field Manuals.

b. **Precautions.** The following additional safety precautions for handling ammunition will also be observed:

(1) Since fragments may be projected over 200 yards, fragmentation grenades will not be used in training without adequate cover.

(2) The safety pin will be removed just before throwing or launching and at no other time.

(3) Occasionally, chemical grenades may flash. Hence, when used in maneuvers, they will be so thrown as to function not less than 30 feet from personnel.

(4) Duds will be disposed of in accordance with the provisions in chapter 4.

(5) *Rifle grenades must never be launched with a cartridge other than the special grenade cartridges provided for that purpose.*

(6) The fuze furnished with the grenade Mk 2 is noiseless, smokeless, and sparkless. Under no condition, therefore, will the thrower consider the grenade a dud because no noise, smoke, or sparks are observed upon release of the safety lever.

**90. IDENTIFICATION.** High-explosive grenades are painted olive-drab with yellow bands around the top of the grenade body. Training hand grenades (inert) are painted black; practice grenades containing a simulated charge are painted blue. Practice rifle grenades are painted black with white stenciling. Chemical grenades are painted blue-gray with identification band and marking in the appropriate color as indicated in chapter I, section II and in figures 11 and 12. The stabilizer assembly of all rifle grenades is painted olive-drab.

**91. PACKING.**

a. Grenades are usually packed as fuzed complete rounds, each in an individual fiber container.

b. Fragmentation grenades are packed 15 or 25 containers per wooden box.

c. The offensive hand grenades are packed 50 per wooden box (fig. 48), and the training grenades are packed 24 per box.

d. The standard packing for rifle grenades is 10 containers per box (fig. 49), with a supply of cartridges for launching from any appropriate weapon. Jungle packing is waterproofed to withstand humid climates.

e. Grenade-projection adapters are packed 48 per box, with sufficient number of various grenade cartridges and positioning clips.



---

*Classes of Ammunition*

---

## Section III

**MORTAR AMMUNITION****92. DESCRIPTION.**

a. To obtain maximum accuracy and range, projectiles for smooth-bore mortars are stabilized by means of fins assembled to a shaft which is secured to the base end of the projectile; when the fins are omitted, the projectile tends to tumble and be erratic in flight.

b. In general, the ammunition has an adjustable propelling charge, consisting of a number of propellant increments, usually sealed in individual cellophane bags, and an ignition cartridge, to permit firing various ranges or zones of fire. The propellant increments are attached to the fin shaft or within the fin blades; the ignition cartridge is inserted in base end of the fin shaft.

c. The primer and ignition cartridge are separate elements. The primer is screwed into the shaft after the ignition cartridge has been inserted. The assembly of the ignition cartridge and the propellant increments make up the required propelling charge; or the ignition cartridges alone may be used for very short range in the 60-mm mortar and with the light-weight round (M43A1) in the 81-mm mortar.

d. Because the complete round (figs. 50 and 51) is loaded into the mortar as a unit and provision is made for adjusting the propelling charge, ammunition of this type comes within the classification of semifixed ammunition.

**93. CLASSIFICATION.**

a. According to the purpose for which it is intended, mortar ammunition is classified as high-explosive, smoke, illuminating, practice, or training.

b. High-explosive mortar shells are used for fragmentation or demolition effect, according to the action of the fuze and design of shell.

c. Smoke shells contain chemical fillers.

d. Illuminating shells are intended for signaling and illuminating purposes.

e. Practice shells may have a spotting charge or may be inert.

f. Training projectiles are provided for training and practice. They are inert and may be fired more than once. Several propelling charges and fins are supplied for each projectile.

*Classes of Ammunition*

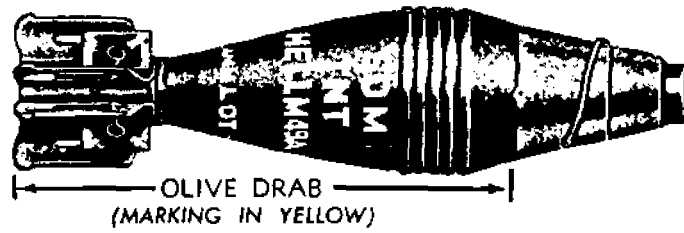

HE SHELL, M49A2, W. PD FUZE, M52

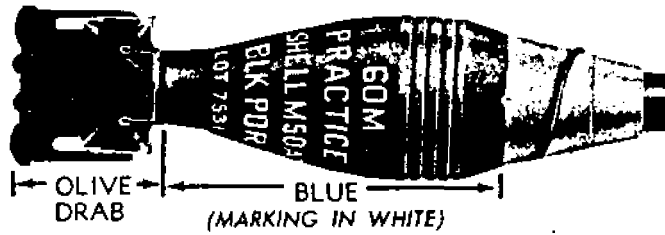

PRACTICE SHELL, M50A2, W. PD FUZE, M52

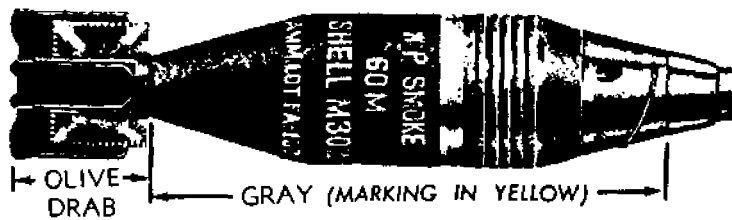

WP SMOKE SHELL, M302, W. PD FUZE, M82

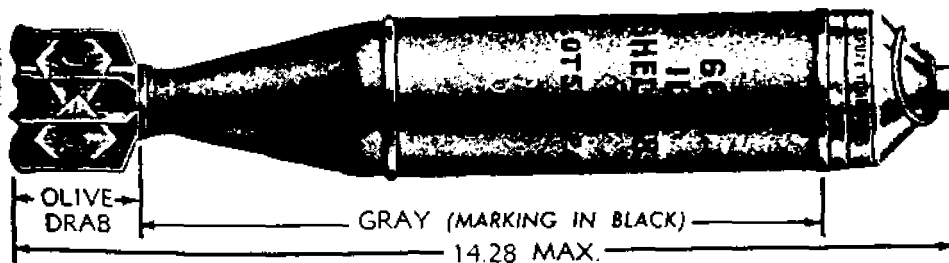

ILLUMINATING SHELL, M83A1, W. TIME FUZE, M65



TRAINING SHELL, M69

RA PD 64448B

*Figure 50 – 60-mm Mortar Ammunition*

Classes of Ammunition

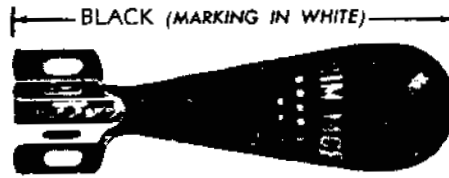

TRAINING SHELL, M68

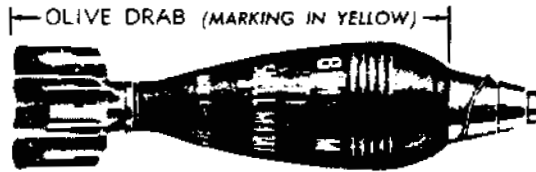

HE SHELL, M43A1, W PD FUZE, M52

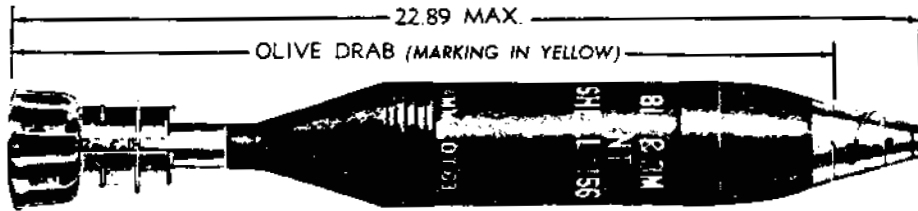

HE SHELL, M56, W PD FUZE, M53A1

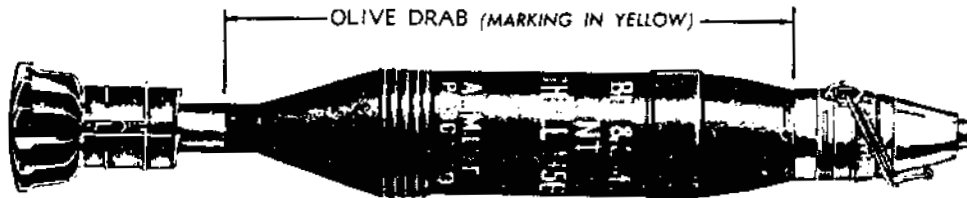

HE SHELL, M56, W TSQ FUZE, M77

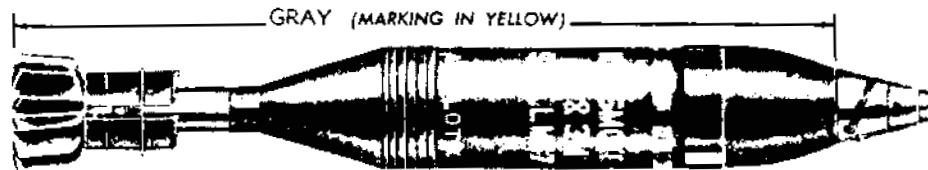

WP SMOKE SHELL, M57, W, PD FUZE, M52

RA PD 64449A

Figure 51 - 81-mm Mortar Ammunition

Classes of Ammunition

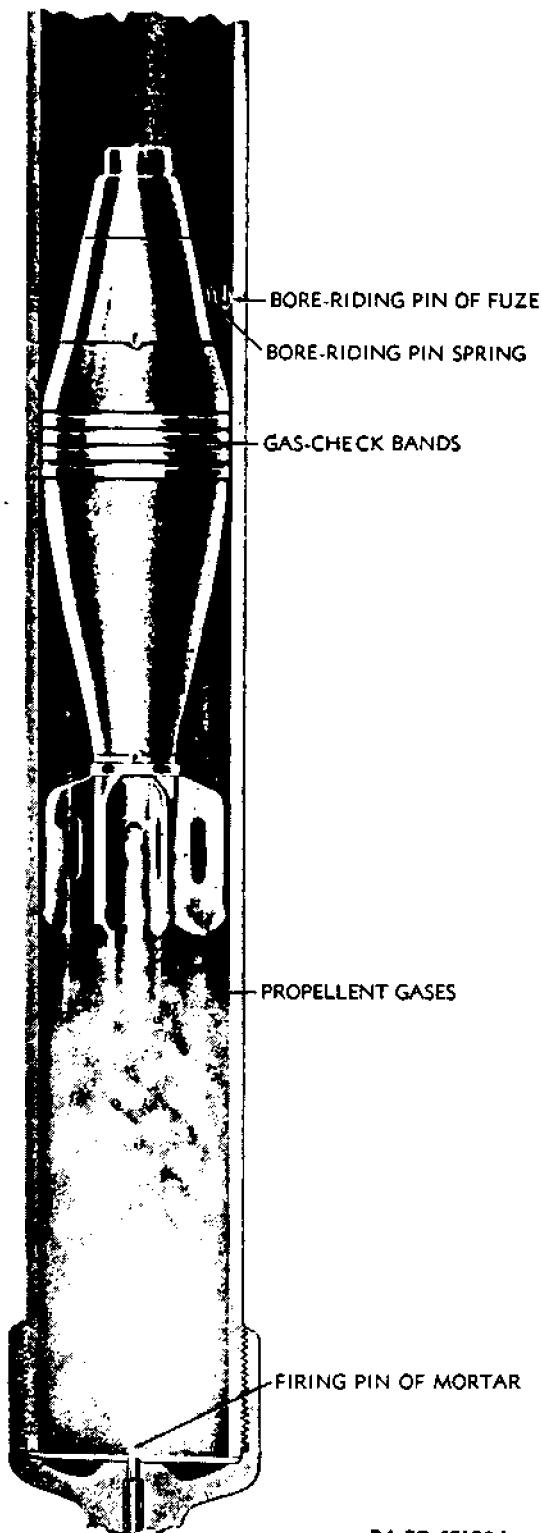

RA PD 65179A

Figure 52 - 60-mm Mortar Shell Being Fired

Classes of Ammunition

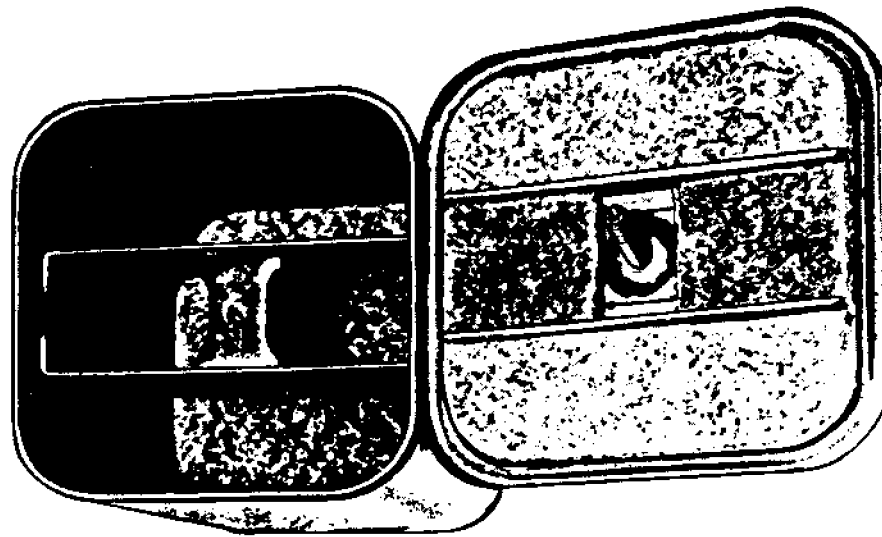

RA PD 97687A

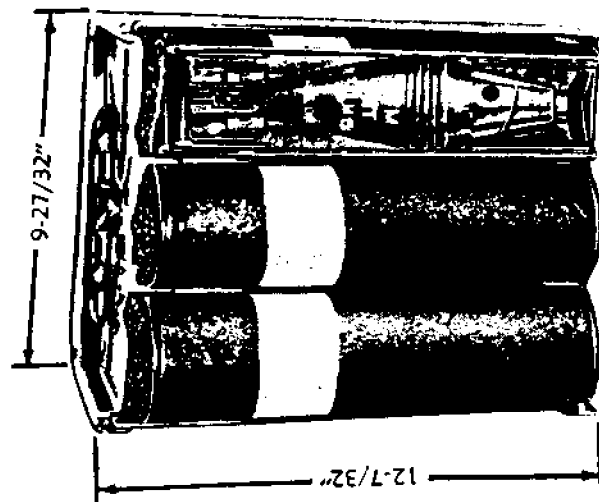
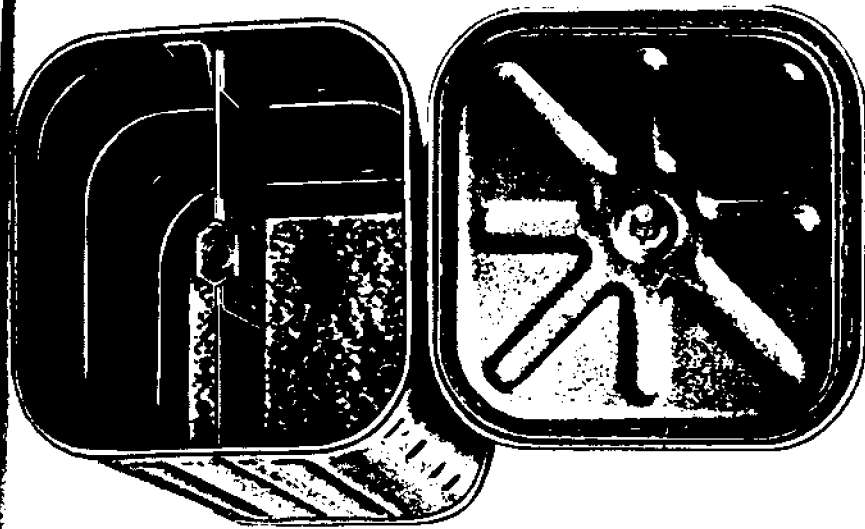

Figure 53 - Metal Container M139A1 for 60-mm Mortar Ammunition

Classes of Ammunition



RA PD 97686

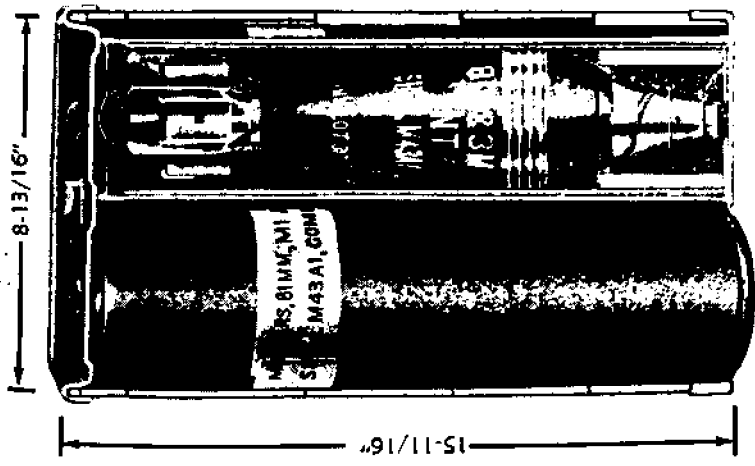

Figure 54 -- Metal Container M140A1 for 81-mm Mortar Ammunition

*Classes of Ammunition*

**94. METHOD OF PROJECTION.** The round is dropped into the mortar tube and upon reaching the bottom of the mortar, the round's primer impinges upon the firing pin of the mortar. This impact sets off the ignition cartridge and propelling charge, and the gas produced forces the round from the mortar (fig. 52). The bourrelet, or gas-check band, prevents practically all the gas from escaping past the shell, and provides a bearing surface for the round in its travel through the bore. A bore-riding pin in the fuze of the shell prevents the fuze from becoming armed until after it leaves the bore of the weapon.

**95. PRECAUTIONS IN HANDLING.**

a. Complete rounds, particularly rounds with fuzes, will be handled with care at all times. Explosive elements in fuzes and primers are particularly sensitive to shock and high temperature.

b. Do not break the moisture-resistant seal on the fiber container until ammunition is to be used.

c. The safety wire will be withdrawn from the fuze only just before firing and at no other time. Be certain the bore-riding pin is in place in the fuze at the time the shell is dropped in the mortar.

d. When loading muzzle-fed mortars, the round is inserted into the mortar, cartridge end first. When the shell is released to slide down the barrel, the hands should be promptly removed from the muzzle.

e. Duds should not be handled or moved. Because their fuzes are armed, they should be destroyed in place as described in chapter 4 of this manual.

**96. PACKING AND MARKING.**

a. **Packing.** Except training ammunition, which may be requisitioned by components, mortar ammunition in the smaller calibers is packed as assembled complete rounds. Each round is packed in an individual fiber container, and then in suitable outer packing. In the case of 60-mm and 81-mm mortar ammunition, clover-leaf bundles, wooden box, or metal containers have been in use. The metal container (figs. 53 and 54) is now the standard packing for this ammunition, but is reserved for shipment to certain theaters.

b. **Marking.** In addition to the painting which identifies the ammunition as to type, the following information is stenciled on the projectiles:

Caliber and type of mortar  
in which fired  
Kind of filler  
Model of shell  
Ammunition lot number

## SECTION V. SMALL ARMS AND TRENCH WARFARE

### Chapter I Small-arms Ammunition

#### GENERAL.

Small arms refers to those weapons normally accompanying foot troops (infantry). They include rifles, automatic rifles, pistols, and machine guns up to cal. .60 (0.60 inches diameter of bore) and also shotguns. Small-arms ammunition is defined as "ammunition fired in weapons whose bore is 0.60 inches or less in diameter." In ordnance, small-arms ammunition is restricted to mean ammunition for those small arms used in military service. These are:

1. Cal. .50 machine guns.
2. Cal. .30 carbines, rifles, semiautomatic rifles, automatic rifles, and machine guns.
3. Cal. .22 pistols, rifles, and machine guns (for gallery practice).
4. Shotguns of 12-gage.
5. Cal. .45 automatic pistols, revolvers, and submachine guns.
6. Subcaliber tubes and adapters for artillery weapons which use ammunition of similar size and type.

**Caliber and Gage.** The caliber of a weapon is the diameter of the bore of the weapon between opposite lands, and in the instance of small arms, is expressed in inches unless millimeters are specifically mentioned. For example, cal. .30, means that the diameter of the bore of the weapon is 0.30 inches.

The gage of a shotgun refers to the number of lead balls of the diameter of the bore required to weigh 1 pound. For example, the diameter of the bore of a 12-gage shotgun is 0.785 inches, and it takes 12 lead balls of this diameter to weigh 1 pound.

**Classification.** Dependent on its purpose, small-arms ammunition is classified as follows:

**Ball.** This type is effective against personnel or light materiel targets.

**Armor-piercing.** This type has a bullet containing a hardened steel core. It is intended for use against armored aircraft and vehicles, concrete shelters, and other bullet resisting targets.

**Tracer.** This type has a bullet containing a chemical composition which burns in flight. It is used for observation of fire, for incendiary purposes, and for signaling.

**Incendiary.** This type has a bullet containing a chemical composition. It is used to start fires.

**Blank.** This type contains no bullet. It is used for simulated fire, for signaling, and for salutes.



AMMUNITION INSPECTION GUIDE

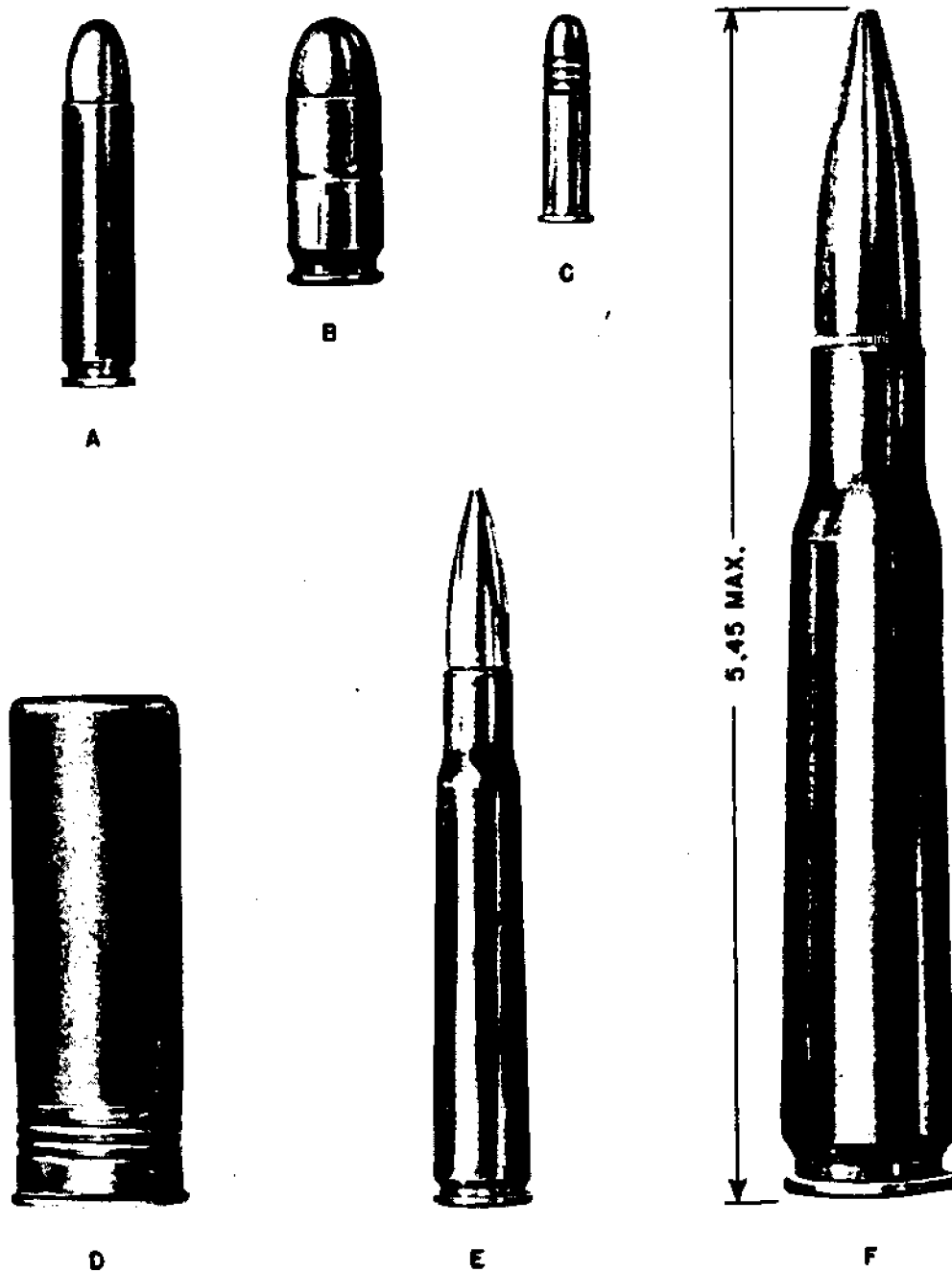

- A - CARTRIDGE, CARBINE, CAL..30, M1
- B - CARTRIDGE, BALL, CAL..45, M1911.
- C - CARTRIDGE, BALL, CAL..22, LONG RIFLE
- D - SHELL, SHOTGUN, 12-GAGE.
- E - CARTRIDGE, BALL, CAL..30, M2
- F - CARTRIDGE, BALL, CAL..50, M2

RA PD 4507

Figure 68 — Types of Small-arms Ammunition

## SMALL ARMS AND TRENCH WARFARE

*Dummy.* This type has no propelling charge or primer. It is used for training.

*Gallery practice.* This type has a reduced charge. It was formerly used for gallery practice, but is now standard for guard ammunition.

*Guard.* This type has a reduced propelling charge. It is used for guard purposes.

*High-pressure test.* This type has an augmented propelling charge. It is used only in proof-firing.

*Rifle grenade.* This type has no bullet. It is used with the rifle grenade.

*Subcaliber.* This type has a rimmed cartridge case. It is used in subcaliber tubes and mounts of cannon.

*Shotgun shells.* These are used for guard purposes, target practice, and hunting.

**Complete Round.** A complete round of small-arms ammunition is known as a cartridge, and is made up of the following components:

1. Cartridge case.
2. Primer.
3. Propelling charge.
4. Bullet.

**Cartridge Case.** The cartridge case is the means whereby the other components are assembled into a unit. It also provides a water-proof container for the propelling charge. When the cartridge is fired, the thin brass is forced against the walls of the chamber by the pressure, thus preventing the escape of gases to the rear. This sealing process is known as obturation. The extraction groove on the case provides a means for extracting the fired cartridge case from the weapon.

**Manufacture.** The cartridge case is made from a circular disc of cartridge brass which is punched into the form of a cup and drawn through successive dies into shape. The closed end is pressed into shape to form the head which contains the primer pocket and vent. An extractor groove is machined in the side of the head to provide a grip for the mechanical extractor of the weapon. The case for pistol ammunition is cylindrical; that for carbine ammunition tapers slightly; that for rifle and machine gun ammunition tapers slightly from the head to the shoulder (approx. three-quarters of its length), then sharply at the shoulder to the cylindrical neck. After each punching or drawing operation, the case is annealed to remove strains.

**Primer.** The primer which is crimped into the primer pocket in the head of the cartridge case, consists of a soft metal cup, a priming or percussion composition, a disc of shellacked manila paper, and an anvil. A blow from the firing pin on the primer cup compresses the

AMMUNITION INSPECTION GUIDE

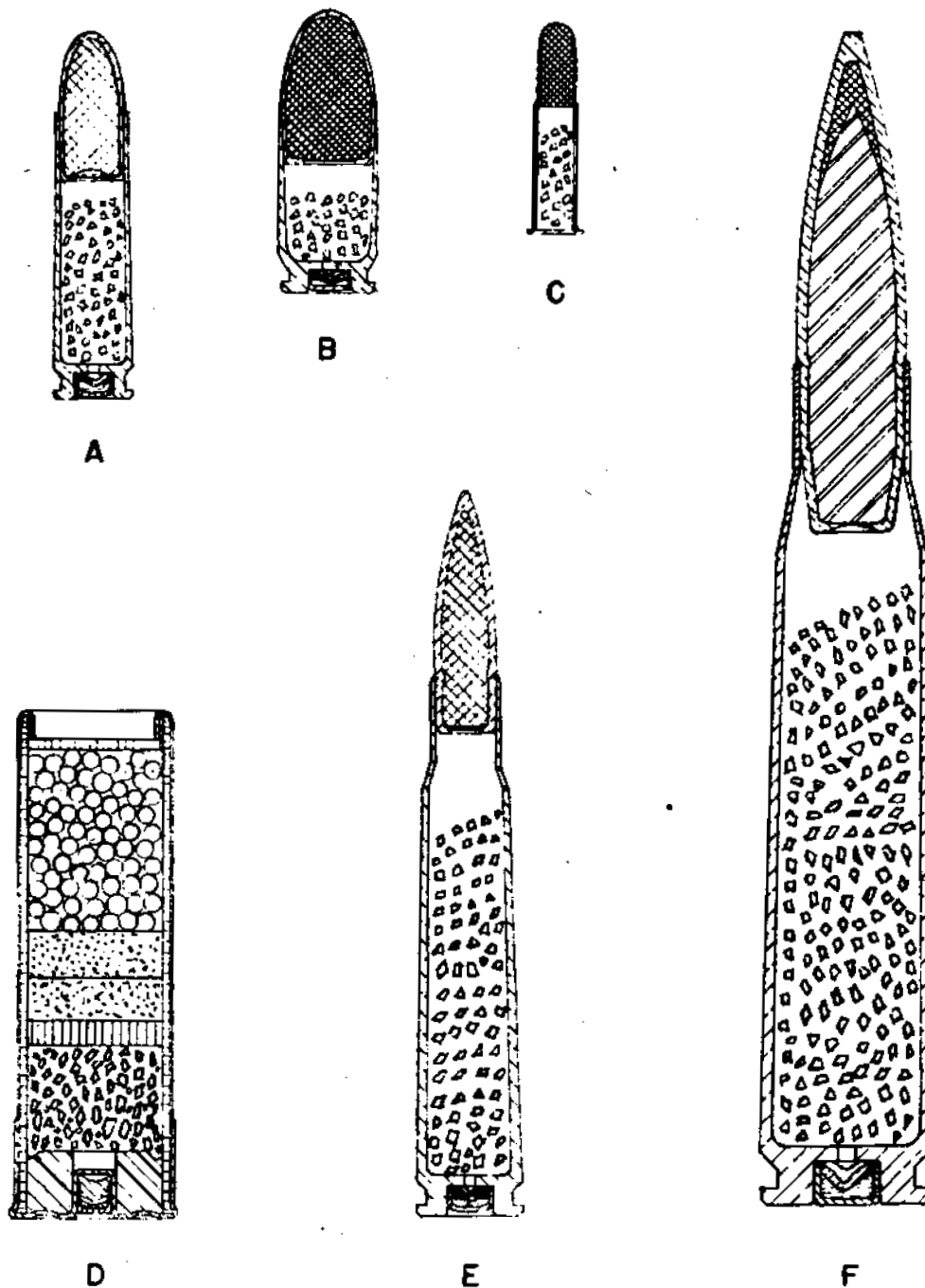

- A CARTRIDGE, CARBINE, CAL. .30, M1.
- B CARTRIDGE, BALL, CAL. .45, M1911.
- C CARTRIDGE, BALL, CAL. .22, LONG RIFLE
- D SHELL, SHOTGUN, 12 GAGE.
- E CARTRIDGE, BALL, CAL. .30, M2
- F CARTRIDGE, BALL, CAL. .50, M2

RA PD 4508

Figure 69 — Cartridges in Section.

SMALL ARMS AND TRENCH WARFARE

- A - CANNELURE
- B - EXTRACTING GROOVE
- C - HEAD
- D - MOUTH
- E - NECK
- F - PRIMER POCKET
- G - SHOULDER
- H - VENT

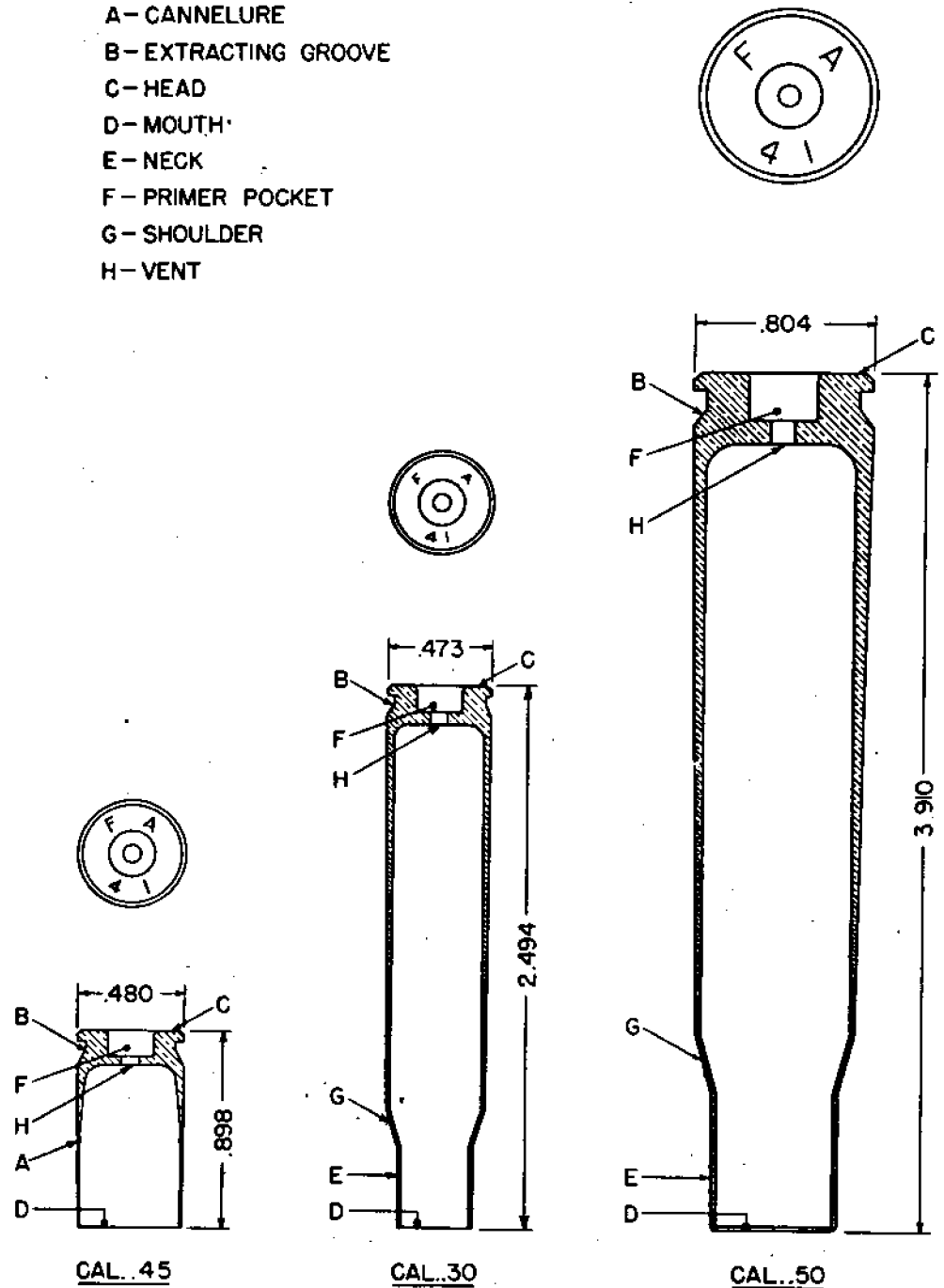

RA PD 4509

Figure 70 — Cartridge Cases in Section

## AMMUNITION INSPECTION GUIDE

- 1-BRASS ANVIL
- 2-BRASS CUP
- 3-GILDING METAL CUP
- 4-PAPER DISK
- 5-PELLET

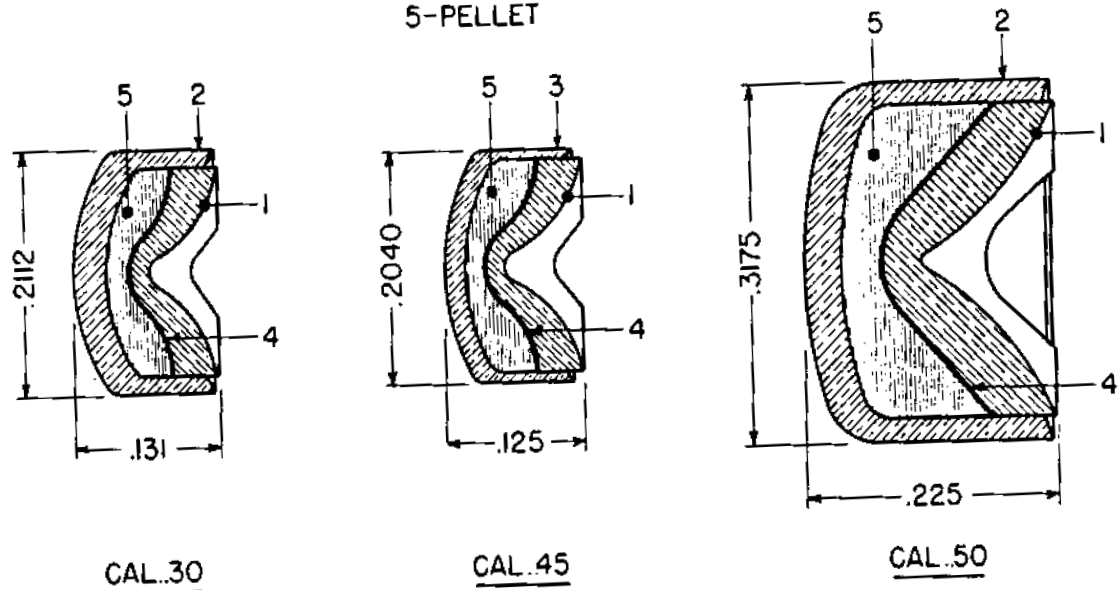

RA PD 4510

Figure 71 — Primers in Section

priming composition between the cup and the anvil, thereby producing a flame which passes through the vents in the anvil and cartridge case, and ignites the propelling charge of smokeless powder. The cup of the cal. .30 or cal. .50 primer is made of brass, whereas the cup of the cal. .45 is made of gilding metal because the lighter blow of the firing pins of pistols and revolvers necessitates a softer material. The priming composition is inserted into the cup and is held in place and protected from moisture and electrolytic action by the paper disc. The brass anvil is inserted last.

Recent primers of the noncorrosive, nonmercuric type are used in some cal. .45 cartridges and in the cal. .30 carbine cartridge. To function properly, primers must be free from such surface defects as folds, wrinkles, scratches, scales, or dents. Other primer defects are cocked, broken, or inverted anvils; scratched, torn, or dirty cups; and missing anvils, discs, or pellets.

**Propelling Charge.** The propelling charge consists of a quantity of smokeless powder. The weight of the charge is not a constant. It is adjusted for each powder lot to give the required velocity with pressure within the limits prescribed for the weapon in which it is fired. The powder charge is assembled loosely in the cartridge case.

Smokeless powder for small-arms ammunition is usually glazed with graphite to facilitate machine loading, and thus presents a black

## SMALL ARMS AND TRENCH WARFARE

polished appearance. Single perforated grains are usually used as small-arms propellants. Since the powder grains are small, they ignite more rapidly and burn more quickly than cannon powder. When abnormal temperatures prevail, small-arms powders are subject to rapid deterioration. Smokeless powder is not as sensitive to friction as black powder, but all precautions used in handling black powder should be observed for small-arms powders.

In general, there are two types of small-arms propellants; the single base nitrocellulose type and the double base type. The double base type is a mixture of nitrocellulose and nitroglycerine which burns more rapidly than the single base type.

**Bullet.** The bullet consists, in general, of a core covered by a gilding metal jacket. A cannelure is cut or rolled in the jacket to provide a recess into which the mouth of the case may be crimped at assembly.

The body of the bullet is cylindrical. The nose may be round, as in the cal. .45 bullet, or ogival (curved taper) as in all service rifle and machine gun bullets. The base may be "square" that is cylindrical, or "boat-tailed"; that is, having a conical taper.

Armor-piercing bullets contain a core of hardened steel. There may be point or base fillers of lead or aluminum filling the spaces between the steel core and jacket.

Bullets of ball cartridges usually contain a slug of antimony hardened lead except in the case of cal. .50, wherein the core is of soft steel in order to insure similar ballistic properties for ball and armor-piercing cartridges.

Tracer bullets contain a lead slug in the forward position, and a chemical composition in the rear.

Incendiary bullets contain an incendiary composition.

Special purpose bullets may vary in shape or composition. These will be described in the section on the particular cartridge.

### Accessories.

**Clips.** Cal. .30 cartridges for use in the M1903 and M1917 Service Rifles, or for both rifle and machine gun use, are assembled in 5-round clips; those for the M1 Rifle are assembled in 8-round clips. In time of peace, the 8-round clips are nonexpendable items.

The 5-round clip consists of a body and spring, both of brass. Stop lugs on the exterior side of the body seat the clip in its slots in the receiver of the rifle. The top edges of the sides are folded inward, forming flanges which fit into the grooves in the cartridge case heads, holding the cartridge in place. The spring is provided with narrow tongues which, when the clip is filled, are pressed into the grooves of the outside cartridges, holding them securely in the clip.

The 8-round clip consists only of a case made of steel. It is indented near the base along the sides to form an inner rib which

AMMUNITION INSPECTION GUIDE

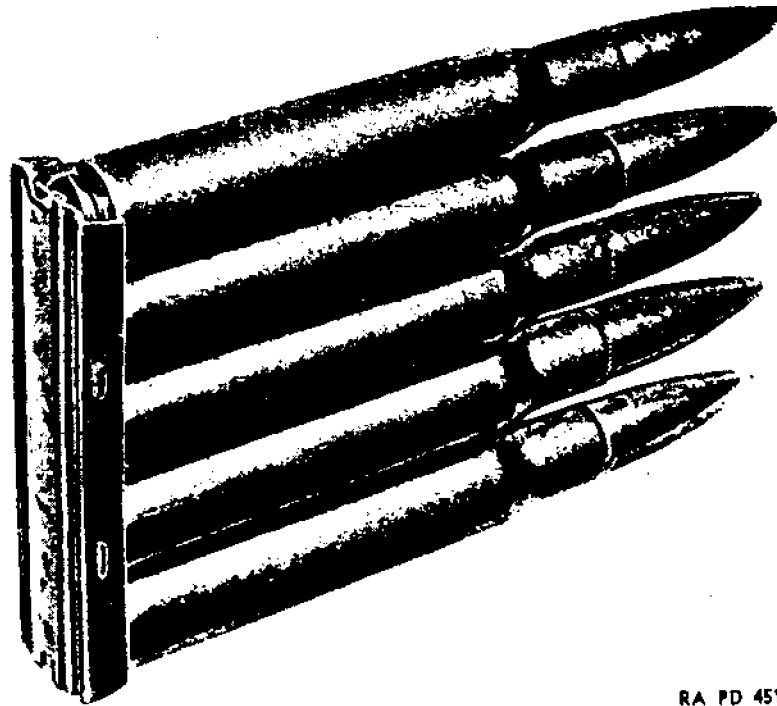

RA PD 4513

*Figure 72 — 5-round Clip for Cal. .30 Cartridges*

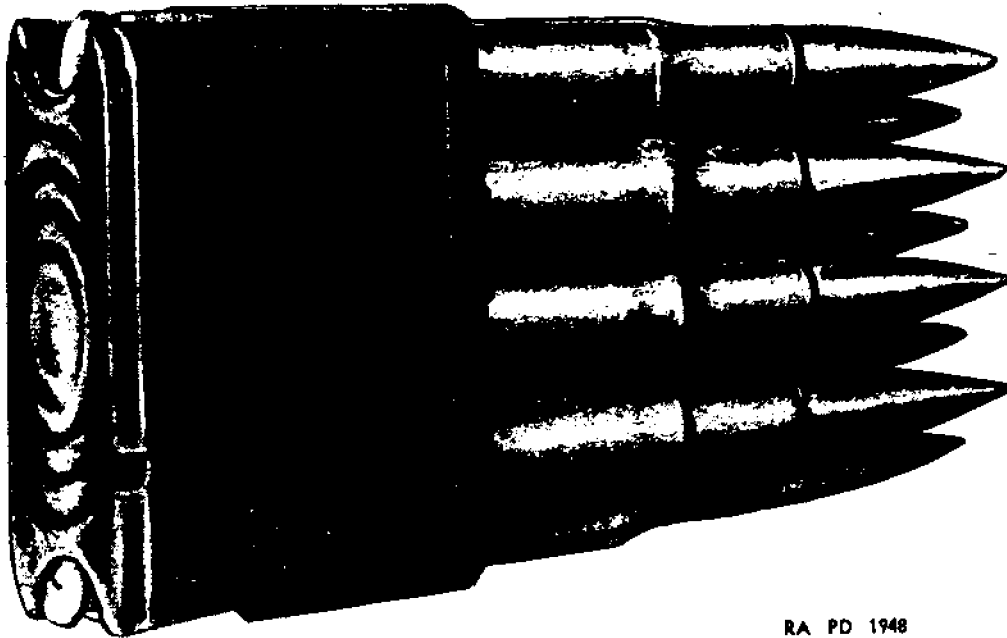

RA PD 1948

*Figure 73 — 8-round Clip for Cal. .30 Cartridges*

engages the extractor groove in the cartridges. The sides are inclined sufficiently to clamp the cartridges firmly in place. The cartridges are held firmly in two staggered rows. It is immaterial whether the

## SMALL ARMS AND TRENCH WARFARE

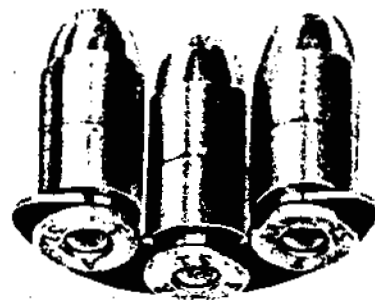

LOADED

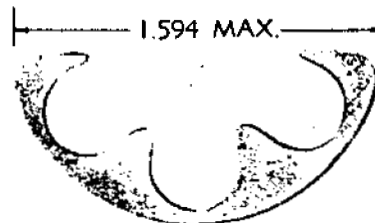

UNLOADED

RA PD 4515A

**Figure 74 — Cartridge Clip for Cal. .45 Revolvers**

uppermost cartridge of the loaded clip is on the left or right side of the clip as the follower slide of the gun adjusts itself for either loading. Experience in the field shows, however, that it is preferable to have the uppermost cartridge in the right side of the clip. The sides are curved at the ends to hold the cartridges securely in the clip.

Cal. .30 dummy cartridges were formerly assembled in a special clip. The present practice is to use the standard 5-round clip without tongues, marked for use with dummy cartridges. The Corrugated Dummy Cartridge, cal. .30, M1906 may be used for instruction in functioning when loaded into 8-round clips.

When used in the revolver, it is necessary to assemble the **CART-RIDGE**, ball, cal. .45, M1911, into clips. These clips are packed separately for assembly in the field. Each consists of a semicircular piece of steel with slots to hold the cartridge. Each clip holds three rounds.

**Metallic belt links.** For use in automatic weapons, cal. .30 and cal. .50 ammunition is issued in metallic link belts. These belts are assemblies of unit links, one for each cartridge. Each link has two loops fitting about one cartridge and a third loop fitting about one adjacent cartridge. Thus, each cartridge in a metallic link belt, except the cartridges on the ends, has two links attached to it. Each link is made from strip steel. A blank form is stamped from the strip and the blank is bent to form the circular loops. It is then heat-treated and



AMMUNITION INSPECTION GUIDE

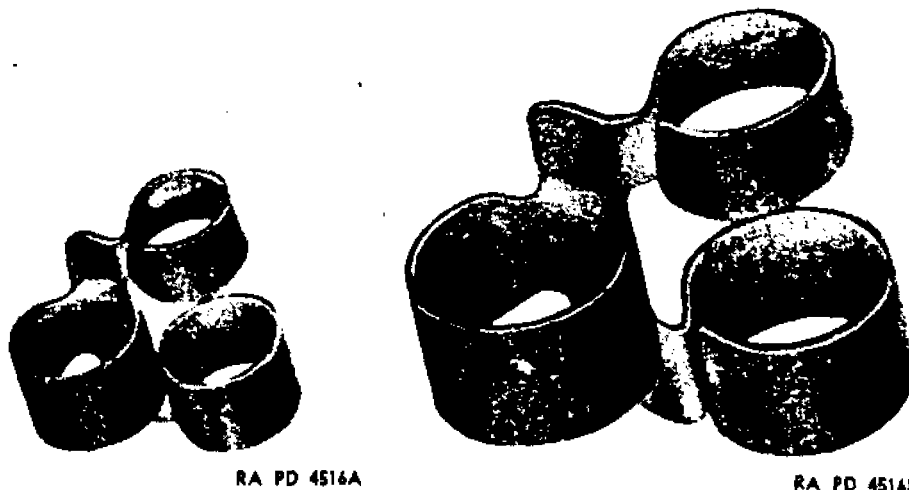

Figure 75—LINK, Metallic Belt, Cal. .30, M1      Figure 76—LINK, Metallic Belt, Cal. .50, M2

processed to prevent rusting. The links are manufactured to meet specified extraction tests from prescribed steel plugs made in the shape of cartridges. LINK, metallic belt, cal. .30, M1, must withstand an extraction pull of 5 to 10 pounds and LINK, metallic belt, cal. .50, M1, or M2, must withstand an extraction pull of 10 to 25 pounds.

**GRADES OF SMALL-ARMS AMMUNITION.**

Ammunition is manufactured to rigorous specifications and is inspected and tested thoroughly before acceptance. Since the various types of weapons; rifles, ground machine guns, aircraft machine guns, etc., have different requirements, production orders and specifications call for the classification of lots for use in specific weapons. Variations in manufacture may occur because of problems of mass production of ammunition. Considering variations from lot to lot and the different requirements for each type of weapon, grades are assigned to each lot of ammunition, in accordance with acceptance tests, to designate their use in the different types of weapons.

Current grades of all existing lots of small-arms ammunition are established by the Chief of Ordnance as a result of inspection and are published in OFSB 3-5. Grades are not marked on packing boxes or on slips inside the box. No lot other than that of grade appropriate for the weapon, as specified in the current publication of OFSB 3-5, will be fired.

The following grades have been established for cal. .30 and .50 ammunition as most appropriate for use in a specific type of weapon:  
 Aircraft machine gun .....AC  
 Aircraft machine gun or rifle.....AC or R

**SMALL ARMS AND TRENCH WARFARE**

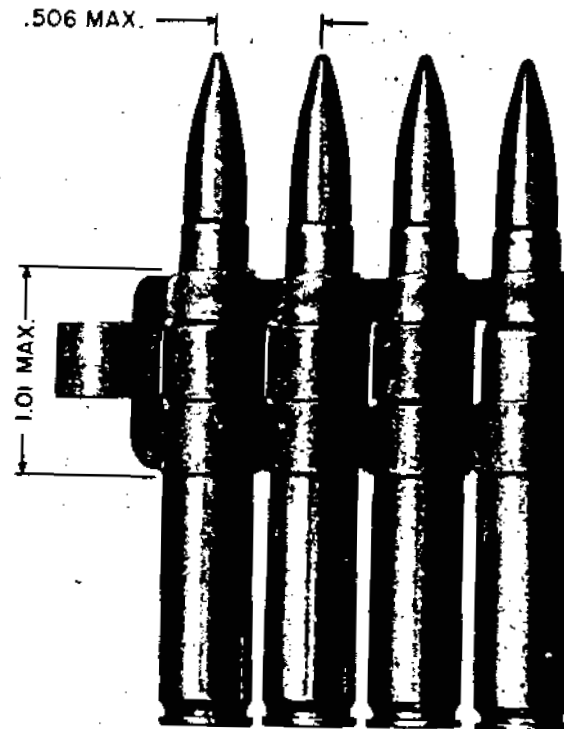

RA PD 4517

**Figure 77 — Section of Cal. .30 Link Belt**

Rifle .....	R
Ground machine gun .....	MG
Unserviceable (not to be issued or used) .....	3

**Priority and Substitution.** The following grades of cal. .30 and .50 ammunition may be used in the weapons specified below. They are listed in the order of priority of issue and use. Indicated substitutions may be made either by Field Service depots or in the field. No other substitutions should be allowed.

For cal. .30:

Grade AC; AC or R .....	For aircraft machine guns
Grade AC; AC or R; MG; R .....	For anti-aircraft machine guns
Grade R; AC or R .....	For rifles, semiautomatic and automatic
Grade MG; R; AC or R; AC .....	For ground machine guns
Grade 3 .....	Not to be issued or used

**EXCEPTION: CARTRIDGE, tracer, cal. .30, M2, is for use in aircraft machine guns only.**

For cal. .50:

Grade AC .....	For aircraft machine guns
Grade AC; MG .....	For anti-aircraft machine guns
Grade MG; AC .....	For ground machine guns
Grade 3 .....	Not to be issued or used

## AMMUNITION INSPECTION GUIDE

**EXCEPTION:** CARTRIDGE, tracer, cal. .50, M2, is for use in aircraft machine guns only.

The following grades have been established for cal. .45 ammunition:

Grade 1. For cal. .45 revolvers, pistols, and submachine guns.

Grade 2. For cal. .45 pistols and submachine guns only. When available, this grade should be issued for these weapons in preference to grade 1.

Grade 3. Not to be issued or used.

For other calibers, the ammunition is considered serviceable unless specifically designated grade 3 (not to be issued or used).

**Linked, Clipped, and Belted Ammunition.** The grades of individual repacked lots of linked, belted, or clipped ammunition, cal. .30 and cal. .50, will not be listed in OFSB 3-5.

For the purpose of issuing and reporting repacked lots, their grades will be considered as follows:

All cal. .30 ammunition in 5- or 8-round clips will be grade R.

All cal. .30 ammunition in web belts will be grade MG.

All cal. .30 ammunition in linked belts will be grade AC.

All cal. .50 ammunition in linked belts will be grade AC.

All cal. .50 ammunition in linked belts with marking "Ground Machine Guns" on box will be grade MG.

All cal. .50 ammunition in linked belts in box, ammunition, cal. .50, M2 (steel) will be grade MG.

All cal. .50 ammunition in web belts will be grade MG.

### Examples of Grading Considerations.

**Grade 3.** When ammunition becomes unserviceable due to some defects such as season crack, corrosion, or other defects, it is designated as grade 3.

Ammunition which has lost its identity is also considered as grade 3. However, unidentified ammunition will not be classified as unserviceable for this reason, until every effort has been made to establish its identity.

Grade 3 ammunition ordinarily will not be issued or used except in the instance of ammunition which is grade 3 because of loss of identity *only*. This ammunition may be issued for practice purposes in the *ground* machine gun only.

It should be kept in mind that in order to positively identify small-arms ammunition, the type, caliber, manufacturer, and lot number must always be known, and that every precaution should be made to maintain this information with a lot of ammunition in any and all operations where the ammunition may become separated from its original packing.

## SMALL ARMS AND TRENCH WARFARE

Some of the considerations taken in grading of ammunition are illustrated by the following examples:

Ammunition to be used in the bolt-action rifle requires that the average net extraction effort shall not exceed 15 pounds. This is essential for uniform and reliable action in a manually-operated weapon but is of lesser importance in automatic and semiautomatic weapons.

Ammunition for use in synchronized and remote controlled aircraft machine guns must be of selected uniformity and have a minimum variation in rate of ignition. These requirements are essential to insure continuous feeding during combat use of aircraft guns, where malfunctioning might result in destruction of propellers or might create other hazards.

Due to the rugged construction of the ground type of machine guns, the continuous control exercised by the operator, and the lower rate of fire, less stringent test limits are required. Ammunition that meets the general specifications for accuracy, pressure, dimensions, etc., is satisfactory.

**Regrading.** Ammunition in storage is periodically retested to insure that its characteristics have not changed. If changes have occurred, as shown by surveillance tests, the ammunition is regraded and the new grades published in OFSB 3-5.

**Priority of Issue, Use and Sale.** In order to provide a sequence for the issuance of small-arms ammunition, the following priorities of issue have been established:

1. Those lots marked with an asterisk in OFSB 3-5.
2. Lots containing less than 20,000 rounds.
3. Lots marked "Repacked-Liners Not Sealed."
4. Lowest or oldest numbered lots.

Following this rule, ammunition which has had the longest or least favorable storage will be issued first whenever practicable.

### AMMUNITION, CAL. 30.

**General.** The ammunition described is designed for use in all standard rifles and machine guns of cal. .30. It includes cartridges of the following types: armor-piercing, ball, tracer, incendiary, blank, dummy, guard, rifle grenade, and high-pressure test.

Cartridges which differ in the type of cartridge case, such as sub-caliber, cal. .30, and carbine, cal. .30, will be described separately.

#### CARTRIDGE, Ball, Cal. .30, M1906.

**General.** While the cal. .30, M1, and cal. 30, M2, Ball Ammunition have superseded the M1906 as standard items, the description of the

**AMMUNITION INSPECTION GUIDE**

latter is of value, in view of the stock of M1906 Ammunition that remains on hand.

*Visual identification.* This cartridge may be distinguished from the M1 and M2 Ball Rounds by the color of the jacket of the bullet, which is cupronickel and has a silvery appearance. Also, the numerals on the head of the cartridge case run from "21" downward.

*Components.* The cartridge consists of a cartridge case, primer, propelling charge, and bullet. The complete assembly weighs approximately 395 grains.

The bullet is pointed, having a square or cylindrical base, and the length of the bullet is approximately 1.085 inches. It has a jacket of cupronickel with a lead core hardened with antimony (97½ percent lead and 2½ percent antimony). The bullet is secured in the neck of the cartridge case by crimping the mouth into a cannelure on the bullet. The pull required to extract the bullet from the case is 75 pounds (minimum bullet pull).

External ballistics, maximum range (approx.).....3,450 yd  
 Average maximum pressure.....52,000 lb per sq in.

**Velocity:**

At 78 ft.....2,640 ft per sec  
 At 53 ft.....2,660 ft per sec  
 At muzzle .....2,700 ft per sec  
 Muzzle energy.....2,429 ft-lb

**CARTRIDGE, Ball, Cal. .30, M1.**

*General.* This cartridge is a limited standard item of issue and is used in the same weapons and for the same purposes as the CARTRIDGE, ball, cal. .30, M2.

*Visual identification.* This cartridge cannot be readily distinguished from the M2 Ball Cartridge of late manufacture except by weight and date.

*Components.* The cartridge consists of a cartridge case, primer, propelling charge, and bullet. The complete assembly weighs approximately 420 grains.

The bullet consists of two parts, a lead alloy core, composed of 90 percent lead and 10 percent antimony, and a gilding metal jacket. An alternative bullet having a gilding metal jacket and a core composed of 97½ percent lead and 2½ percent antimony may also be used. The base of either bullet has a 9-degree taper, called a boat-tail. The over-all length of the M1 Bullet is 1.32 inches, and that of the M1 Alternative Bullet, 1.265 inches. The mouth of the cartridge case is crimped into the knurled cannelure at assembly and a minimum pull of 45 pounds is required to remove the bullet from the case.

**SMALL ARMS AND TRENCH WARFARE**

External ballistics, maximum range (approx.).....5,500 yd  
 Average maximum pressure.....48,000 lb per sq in.  
 Velocity:  
     At 78 ft.....2,600 ft per sec  
     At 53 ft.....2,620 ft per sec  
     At muzzle .....2,647 ft per sec  
 Muzzle energy.....2,675 ft-lb

*Accuracy.* Average of mean radii of all targets at 500 yards, not greater than 4.5 inches; at 600 yards, 5.5 inches, when fired from a Mann accuracy weapon. Dispersions obtained from firings under service conditions at all ranges are published in firing tables for the weapons in which this ammunition is used.

**CARTRIDGE, Ball, Cal. .30, M2.**

*General.* This cartridge is a current standard item of issue and is used in machine guns and rifles against personnel and light materiel targets.

*Visual identification.* Cartridges of recent manufacture cannot be readily distinguished from the M1 Cartridges by visual inspection, although this can be done by weight and date. Cartridges manufactured prior to September 20, 1940, could be readily distinguished from the M1 Cartridges by their tin-coated, gilding metal bullet jackets.

*Components.* The cartridge consists of a cartridge case, primer, propelling charge, and bullet. The complete assembly weighs approximately 396 grains.

The bullet consists of two parts, a lead alloy core, composed of 90 percent lead and 10 percent antimony, and a gilding metal jacket. An alternative bullet having a gilding metal jacket, and a core composed of 97½ percent lead and 2½ percent antimony may also be used. The base of the bullet retains its cylindrical shape to the base line. The over-all length of the M2 Bullet is 1.125 inches, and that of the M2 Alternative Bullet is 1.103 inches. A minimum pull of 45 pounds is required to remove the bullet from the case.

External ballistics, maximum range (approx.).....3,500 yd  
 Average maximum pressure.....50,000 lb per sq in.  
 Velocity:  
     At 78 ft.....2,740 ft per sec  
     At 53 ft.....2,755 ft per sec  
     At muzzle .....2,805 ft per sec

*Accuracy (from accuracy rifle).* Average of mean radii of all targets of 500 yards not greater than 6.5 inches; at 600 yards not greater than 7.5 inches.

**AMMUNITION INSPECTION GUIDE**

**CARTRIDGE, Armor-piercing, Cal. .30, M2.**

*General.* This cartridge is a current standard item of issue and is fired from machine guns and rifles. It is designed for use against armored aircraft, armored vehicles, concrete shelters, and similar bullet-resisting targets.

*Visual identification.* This cartridge may be identified by the additional cannellure and the blackened tip of the bullet.

*Components.* The cartridge consists of a cartridge case, primer, propelling charge, and bullet. The complete assembly weighs approximately 414 grains.

The bullet consists of four parts: a gilding metal jacket, a tungsten chrome steel core, a lead "T"-shot point filler, and a gilding metal base filler. The over-all length of this bullet is 1.370 inches and its point is blackened for a distance of approximately  $\frac{9}{32}$  inch. The base of the bullet is cylindrical down to the base line where it has a slightly beveled edge. The mouth of the case is crimped into the cut cannellure at assembly, and a minimum pull of 45 pounds is required to remove the bullet from the case.

External ballistics, maximum range (approx.) . . . . . 3,500 yd  
 Average maximum pressure . . . . . 50,000 lb per sq in.

*Velocity:*

At 78 ft. . . . . 2,715 ft per sec  
 At 53 ft. . . . . 2,730 ft per sec  
 At muzzle . . . . . 2,775 ft per sec

*Accuracy.* Average of mean radii of all targets at 500 yards, not greater than 9.0 inches; at 600 yards not greater than 10.0 inches.

**CARTRIDGE, Tracer, Cal. .30, M1.**

*General.* This cartridge is a standard item of issue and is used in both machine guns and rifles. It is intended for use with either type of ammunition to show the gunner, by its trace, the path of the bullets. While tracer cartridges were primarily intended for machine gun use, there are cases wherein they can be advantageously used in rifles; for example, for signal and incendiary purposes, target designation, and range estimation.

*Visual identification.* The cartridge is readily identified by its characteristic red bullet point, red indicating the color of the trace.

*Components.* The cartridge consists of a cartridge case, primer, propelling charge, and bullet. The complete assembly weighs approximately 396 grains.

The bullet consists of four parts: a gilding metal jacket, a lead alloy slug, a tracer composition, and an igniter composition. The over-all length of this bullet is 1.45 inches and the point is painted red for a distance of approximately  $\frac{5}{16}$  inch. It has a square base which contains the igniter composition which is ignited by the propel-

**SMALL ARMS AND TRENCH WARFARE**

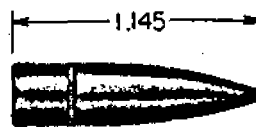

BULLET, BALL, CAL. .30, M2

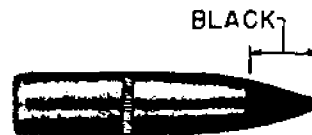

BULLET, ARMOR-PIERCING, CAL. .30, M2

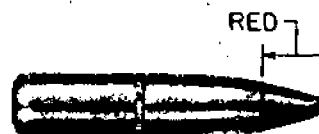

BULLET, TRACER, CAL. .30, M1

RA PD 4521

**Figure 78a — Bullets, Cal. .30**

ling charge when the cartridge is fired. The tracer composition burns with a bright red flame which enables the course of the bullet to be followed by the gunner. The mouth of the cartridge case is crimped into the knurled cannelure at assembly, and a minimum pull of 45 pounds is required to remove the bullet from the case.

Exterior ballistics, maximum range (approx.) . . . . . 3,450 yd  
 Range of trace . . . . . trace begins at a distance not greater than  
 125 yd from the weapon, and bullets continue tracing to 750 yd from the weapon  
 Average maximum pressure . . . . . 50,000 lb per sq in.

Velocity:  
 At 78 ft. . . . . 2,650 ft per sec  
 At muzzle . . . . . 2,715 ft per sec

Accuracy. Average of mean radii of all targets at 600 yards less than 15 inches.

*Trajectory.* This ammunition is designed so that the bullet's trajectory will cross the trajectory of Ball M2, and AP, M2 Ammunition of the same caliber at approximately 600 yards.

**CARTRIDGE, Incendiary, Cal. .30, M1.**

*General.* This cartridge is a standard item of issue for machine guns.



**AMMUNITION INSPECTION GUIDE**

- A-BASE FILLER-GILDING METAL
- B-COMPOSITION, IGNITER
- C-COMPOSITION, TRACER
- D-CORE-TUNGSTEN CHROME STEEL
- E-JACKET-GILDING METAL
- F-POINT FILLER-LEAD "T" SHOT
- G-SLUG-LEAD WITH ANTIMONY



BULLET, BALL, CAL. .30, M2

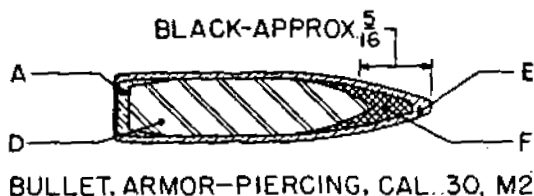

BULLET, ARMOR-PIERCING, CAL. .30, M2

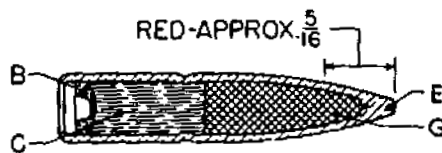

BULLET, TRACER, CAL. .30, M1.

RA PD 4511A

**Figure 78b — Bullets, Cal. .30 — Sectioned**

*Visual identification.* The cartridge resembles the CARTRIDGE, ball, cal. .30, M2, in outward appearance, but it may be identified by the light blue paint on the tip of the bullet.

*Components.* The cartridge consists of a cartridge case, primer, propelling charge, and bullet.

The bullet consists of four parts: a gilding metal jacket, a hollow steel cylindrical core, an incendiary composition, and a lead base filler. The mouth of the cartridge case is crimped into the knurled cannellure at assembly and a minimum pull of 45 pounds is required to remove the bullet from the case.

**CARTRIDGE, Rifle Grenade, Cal. .30, M3.**

*General.* This cartridge is used in cal. .30 Rifles, M1, M1903, M1903A1, and M1917, for discharging antitank rifle grenades.

SMALL ARMS AND TRENCH WARFARE

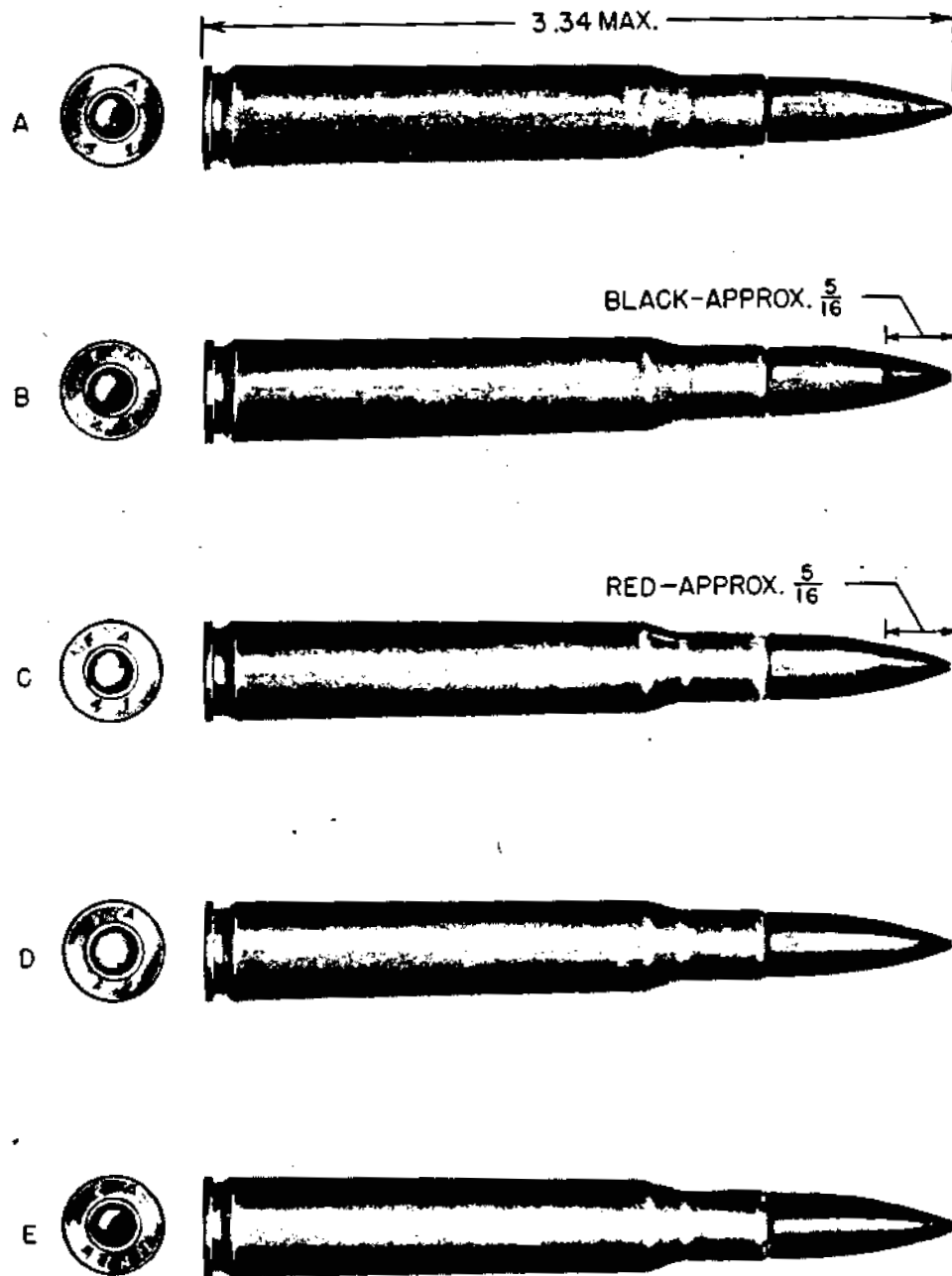

- A - CARTRIDGE, ARMOR-PIERCING, CAL..30, M2
- B - CARTRIDGE, BALL, CAL..30, M2
- C - CARTRIDGE, TRACER, CAL..30, M1
- D - CARTRIDGE, BALL, CAL..30, M1
- E - CARTRIDGE, BALL, CAL..30, M2, NATIONAL MATCH

RA PD 4522

Figure 79a — Cartridges, Cal. .30

AMMUNITION INSPECTION GUIDE

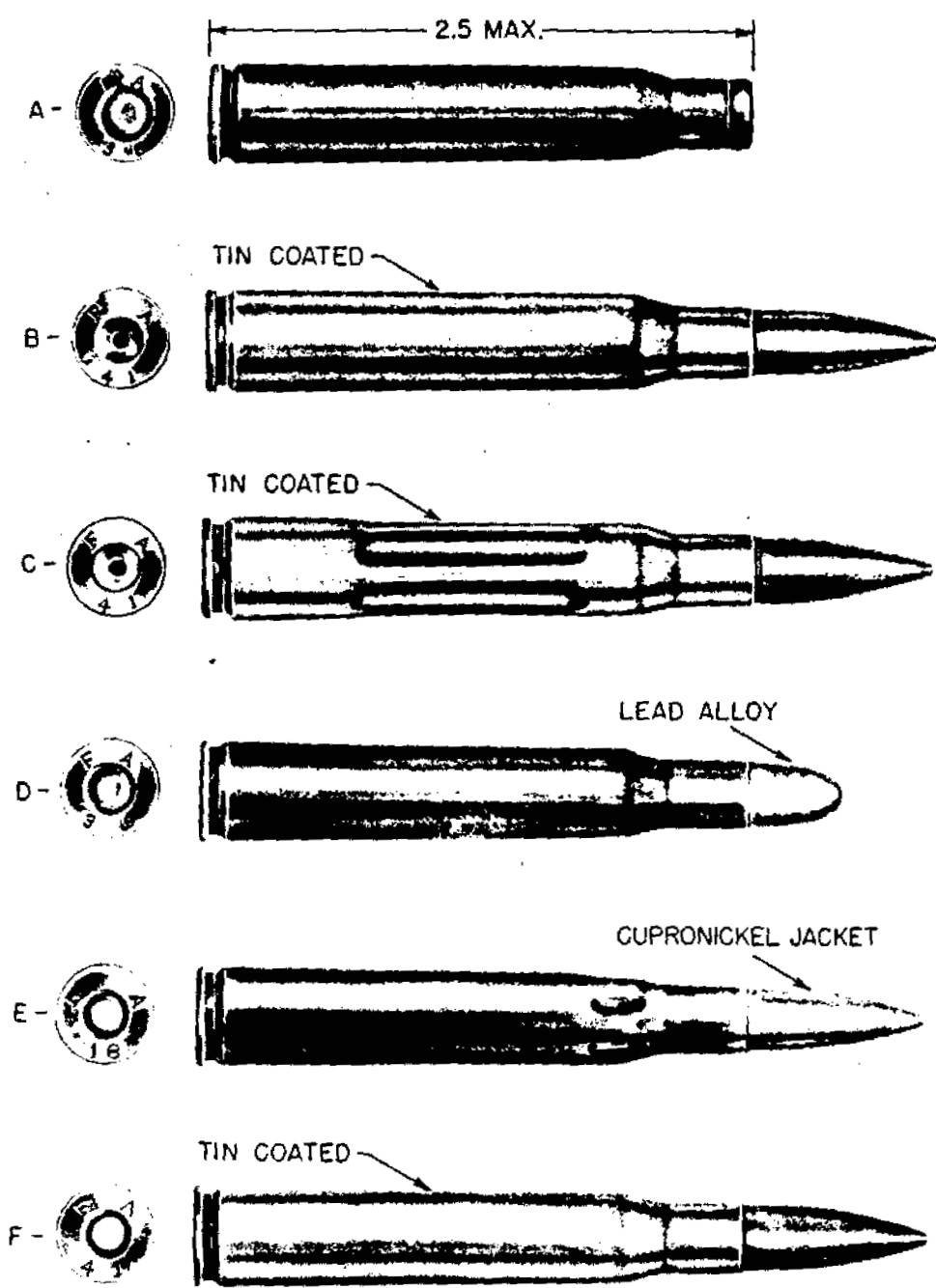

- A- CARTRIDGE, BLANK, CAL..30, M1909
- B- CARTRIDGE, DUMMY, CAL..30, M2
- C- CARTRIDGE, DUMMY, CAL..30, M1906
- D- CARTRIDGE, GUARD, CAL..30, M1
- E- CARTRIDGE, GUARD, CAL..30, M1906
- F- CARTRIDGE, HIGH PRESSURE TEST, CAL..30, M1

Figure 79b — Cartridges, Cal. .30 — Continued

RA PD 4523

## SMALL ARMS AND TRENCH WARFARE

cartridge must not be used in lieu of the cal. .30, M1909 Blank Cartridge in automatic weapons, nor should it be fired in the direction of personnel.

*Visual identification.* This cartridge may be identified by the absence of a bullet and by the 5-petal rose crimp in the mouth of the case.

*Components.* The cartridge consists of a cartridge case, primer, and propelling charge, having no bullet. The complete assembly weighs approximately 246 grains.

The case is the same as the standard cal. .30 case except for a cannellure located about  $\frac{1}{4}$  inch from the mouth. A wad is seated immediately above the cannellure after the propelling charge has been inserted. A drop of red lacquer is applied to the wad, and the mouth of the case is closed by crimping in the shape of a 5-leaf rosette. The cartridge is first loaded with a charge of 5 grains of black rifle powder, then with a progressive-burning small-arms powder.

*Exterior ballistics.* The cartridge, grenade, cal. .30, M3, is loaded to obtain a grenade velocity of 165 feet per second at 5.5 feet.

### CARTRIDGE, Blank, Cal. .30, M1909.

*General.* This cartridge is a current standard item of issue and is used in the U. S. Rifles, M1903 and M1917, for simulated fire during maneuvers, for signaling purposes, and for firing salutes. It is also used in the machine guns and automatic rifles equipped with blank firing attachments, in order to operate these weapons for instructional purposes.

*Visual identification.* It is readily identified since it has no bullet, and furthermore, a cannellure is present in the neck of the cartridge case.

*Components.* The cartridge consists of a cartridge case, primer, propelling charge, and a paper cup or wad of thin paper. Prior to January, 1925, a felt wad was used but was discontinued due to accidents caused by the clogging of gas escape holes in the blank firing attachment of machine guns and automatic rifles. The complete assembly weighs approximately 207 grains.

The cartridge case differs from the standard cal. .30 cartridge case described previously, only in that the neck has a cannellure and that the mouth is slightly rounded. Second class cartridge cases having small dents, scratches, or other minor defects may be used in the assembly of this ammunition.

The propelling charge for this cartridge differs from the standard cal. .30 propelling charge in that E. C. Blank Fire Powder is used in place of the standard smokeless powder.

**AMMUNITION INSPECTION GUIDE**

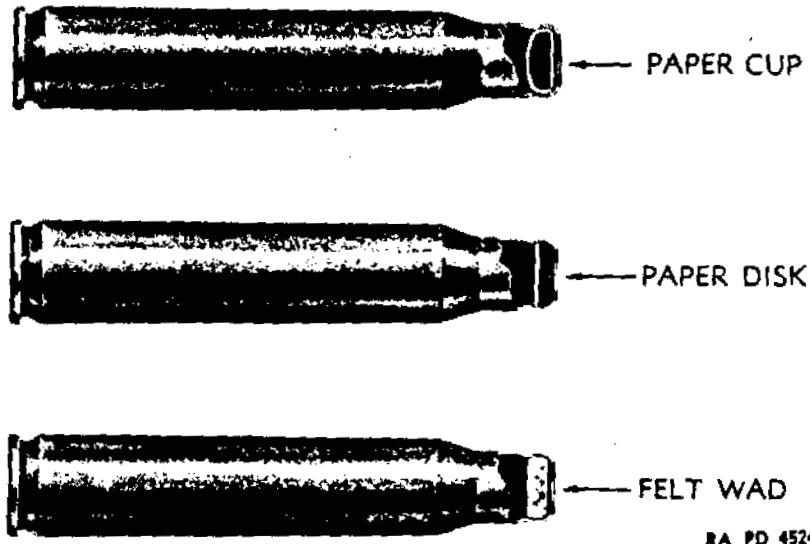

RA PD 4524

**Figure 80 — Blank Cartridges — Necks in Section Showing Wads**

The paper wad or cup is inserted in the neck against the cannelure and sealed in place with a few drops of shellac. The mouth of the case is roll-crimped to keep the wad in place.

**CARTRIDGE, Gallery Practice, Cal. .30, M1919.**

*General.* This cartridge is now superseded by the cal. .22 ball cartridge long rifle for gallery practice. Stocks on hand, however, are retained for guard purposes, for use when the supply of CARTRIDGE, guard, cal. .30, M1906, is exhausted. Cartridges of older manufacture are labeled cartridge, gallery practice, but new manufacture will be designated CARTRIDGE, guard, cal. .30, M1. This cartridge is described under that heading.

**CARTRIDGE, Guard, Cal. .30, M1.**

*General.* This cartridge was formerly the CARTRIDGE, gallery practice, cal. .30, M1919. It is now standard for guard purposes, and is used only in the cal. .30 rifle.

*Visual identification.* It is easily identified by its short, round nose, lead bullet.

*Components.* The cartridge consists of a cartridge case, primer, propelling charge and bullet. The complete assembly weighs approximately 346 grains.

The bullet is composed of a lead alloy and has a round nose and a cylindrical base. Its over-all length is approximately 0.815 inch and it has two knurled cannelures. A pull of not less than 45 pounds is required to remove the bullet from the case.

Exterior ballistics, maximum range (approx.).....2,500 yd  
 Average maximum pressure.....15,000 lb per sq in.

## SMALL ARMS AND TRENCH WARFARE

### Velocity:

At 53 ft.....	1,100 ft per sec
At muzzle .....	1,200 ft per sec
Muzzle energy .....	376 ft-lb

*Accuracy.* At 100 yards, the group diameter will be not greater than 6 inches.

### CARTRIDGE, Guard, Cal. .30, M1906.

*General.* This cartridge is a limited standard item of issue and is used in the cal. .30 rifle for guard purposes. Second class bullets and cartridge cases may be used in the assembly of this cartridge.

*Visual identification.* This cartridge is readily identified by its six short corrugations, called flutes, just below the neck of the cartridge case.

*Components.* The cartridge consists of a cartridge case, primer, propelling charge, and bullet. The complete assembly weighs 355 grains.

The cartridge case is essentially the same as the cal. .30 case previously described, except that it has six short flutes or corrugations just below the neck.

The bullet consists of a cupronickel jacket encasing a lead alloy slug. It has a cylindrical base.

Exterior ballistics, maximum range (approx.).....	2,000 yd
Average maximum pressure.....	15,000 lb per sq in.
Muzzle velocity.....	1,200 ft per sec
Muzzle energy.....	479 ft-lb

### CARTRIDGE, Dummy, Cal. .30, M1906.

*General.* This cartridge is a current standard item of issue and is used for training personnel in the operation of loading and unloading rifles, and simulating rifle fire. Prior to January 15, 1940, this cartridge was assembled only with the M1906 Bullet. Since then, however, it has been permissible to also use either the M2 or M1 Ball Bullet.

*Visual identification.* There are six longitudinal corrugations on the tinned cartridge case. Before January 15, 1940, the cartridge case contained an inert primer and three holes, 0.125 inch in diameter, drilled through the case in alternate corrugations. Since that date, the cartridge has been assembled without a primer and the holes are omitted.

*Components.* The cartridge consists of a cartridge case and a bullet. The complete assembly weighs 339 grains when assembled with either the M2 or M1906 Bullet, and 363 grains when assembled with the M1 Ball Bullet. Second class components are used in the car-

## AMMUNITION INSPECTION GUIDE

Cartridge Cal. .30	Status	Primer Cup	Cartridge Case	Ogive	Base
BALL M1	S	Brass	Brass	Pointed	Tapered
BALL M2	S&M	Brass	Brass	Pointed	Square
TRACER M1	S&M	Brass	Brass	Pointed	Square
ARMOR-PIERCING M2	S&M	Brass	Brass	Pointed	Square
INCENDIARY M1	S&M	Brass	Brass	Pointed	Square
RIFLE GRENADE M3	S&M	Brass	Brass		
BLANK M1909	S&M	Brass	Brass		
GALLERY PRACTICE M1919	S	Brass	Brass	Rounded	Square
GUARD M1906	S	Brass	Brass (6 Flutes)	Pointed	Square
GUARD M1	S&M	Brass	Brass	Rounded	Square
DUMMY CORR. M1906 (Prior to 1-15-40)	S	Brass	Brass(tinned) 6 Corrugations 3 Holes	Pointed	Square
DUMMY CORR. M1906 (After 1-15-40)	S&M		Brass(tinned) 6 Corrugations No Holes		
DUMMY SLOTTED M1		Inert	Brass 1 Slot near head	Pointed	Tapered
DUMMY M2	S&M		Brass(tinned) No Slot	Pointed	Square
HIGH-PRESSURE TEST M1		Brass	Brass(tinned) "TEST" on head	Pointed	Square

## SMALL ARMS AND TRENCH WARFARE

BULLET				REMARKS
Jacket	Point Filler	Core	Base Filler	
Gilding Metal		Lead Antimony		Cartridge case has numerals "25" and above on head
Gilding Metal		Lead Antimony		Cartridge case has numerals "38" and above on head (38-40 jacket tinned, 40-up not tinned)
Gilding Metal	Lead Antimony	Tracer Mixture	Igniter Mixture	Tip of bullet painted red
Gilding Metal	Lead (T Shot)	Tungsten Chrome Steel	Gilding Metal	Tip of bullet painted black
Gilding Metal		Incendiary Mixture		Tip of bullet painted blue
				Mouth rose crimped
				Mouth roll crimped
		Lead		
Cupronickel		Lead Antimony		
		Lead		
Cupronickel		Lead Antimony		
				May use M1906, M1, or M2 Bullets
Gilding Metal		• Lead Antimony		Range dummy
Gilding Metal		Lead Antimony		Used in inspection of weapons Not issued to troops
Gilding Metal		Lead		Used to test for breech pressure Not issued to troops



**AMMUNITION INSPECTION GUIDE**

tridge assembly. The cartridge case is essentially the cal. .30 case described previously, but is corrugated and tinned for identification purposes.

**CARTRIDGE, Dummy, Cal. .30, M1.**

*General.* This cartridge is a standard item of issue for use when assembled in clips with live ammunition on the range for detecting and correcting flinching and faulty trigger squeeze. The use of these cartridges in rifle practice requires that they be mixed with service cartridges without visual detection by personnel. They must therefore closely resemble the service cartridges with which they are mixed. The primers are inert and the cartridge cases do not contain a powder charge.

*Visual identification.* These cartridges are identified by a longitudinal slot, 0.06 inch wide, cut in the body of the case beginning at the extractor groove and continuing to a point approximately 0.687 inch from the head. The depth of this slot tapers from 0.03 inch at the extractor groove to 0.0 inch at the end farthest from the head of the case. When this ammunition is assembled in clips with service ammunition, the slot is hidden from view by turning it toward the adjoining cartridge.

*Components.* The cartridge consists of a cartridge case, inert primer, and bullet. The bullet may be either the M2 or M1 Ball Bullet depending on the type which is to be simulated. When using the M2 Ball Bullet, the complete assembly weighs approximately 340 grains. When using the M1 Ball Bullet, the complete assembly weighs approximately 364 grains. Second class components are generally used in the assembly of these cartridges.

**CARTRIDGE, Dummy, Cal. .30, M2.**

*General.* This cartridge is used only in the inspection of weapons and will not be issued to the service.

*Visual identification.* This cartridge is easily identified by its tinned brass cartridge case and the absence of a primer. It differs from the Dummy M1906 in not having corrugations in the case.

*Components.* The cartridge consists of a cartridge case, and bullet. Second class components may be used in the assembly of this cartridge. The complete assembly weighs approximately 341 grains.

The cartridge case is the same as the standard cal. .30 case except that it is tinned for identification purposes.

The bullet consists of a gilding metal jacket encasing a lead alloy core. It is a ball M2 Bullet, and prior to September 20, 1940, was tin-coated for further identification.

## SMALL ARMS AND TRENCH WARFARE

**CARTRIDGE, High-pressure, Test, Cal. .30, M1.** This cartridge is used for proof-firing rifles, automatic rifles, and machine guns. It is loaded with a powder charge sufficient to give a breech pressure of approximately 68,000 pounds per square inch. Due to this excessive pressure, and the consequent danger involved in firing, the guns under test are fired from a fixed rest under a hood by means of a mechanical firing device. This cartridge may be fired only by authorized personnel.

*Visual identification.* This cartridge is identified by its tinned cartridge case. Some models have the word "Test" stamped on the head.

*Components.* The cartridge consists of a cartridge case, primer, propelling charge, and bullet. The complete assembly weighs approximately 433 grains.

The cartridge case is the same as those used in the service cartridges and is further identified by being tinned.

The bullet consists of a gilding metal jacket encasing a hardened lead core, and has a cylindrical base. Its over-all length is 1.235 inches. The mouth of the case is crimped into the knurled cannelure at assembly and a pull of not less than 40 pounds is required to remove the bullet from the case.

### AMMUNITION, CAL. .45.

**General.** The ammunition described in this discussion is designed for use in all standard revolvers, pistols, and submachine guns of cal. .45. It includes cartridges of the following types: ball, tracer, blank, dummy, and high-pressure test.

#### CARTRIDGE, Ball, Cal. .45, M1911.

*General.* This cartridge is a current standard item of issue and is used in the Automatic Pistol M1911 and M1911A1, the Colt Revolver M1917, the Smith and Wesson Revolver M1917, and the Thompson Submachine Gun M1928 and M1928A1 against personnel. To adapt it for use in the revolvers, it must be assembled in clips designed for this purpose.

*Components.* The cartridge consists of the cartridge case, primer, propelling charge, and the bullet. The complete assembly weighs approximately 327 grains.

The bullet has a round nose and a flat base. It consists of two parts, a gilding metal jacket and a slug of lead hardened with antimony. In early designs, bullet jackets were made of cupronickel and these have a silvery appearance. This was later changed to gilding metal which was given a thin tin wash which has a close resemblance to the cupronickel jacket. The practice of tinning the jackets has since been discontinued and the bullets of current design have the natural copper color of gilding metal. The over-all length of the

**AMMUNITION INSPECTION GUIDE**

bullet is 0.68 inch. The mouth of the case may be crimped to the bullet and a pull of approximately 40 pounds is required to remove the bullet from the case.

Exterior ballistics, maximum range:

In pistol .....1,600 yd  
 In submachine gun.....1,700 yd  
 Pressure.....14,000 lb per sq in.

Velocity:

Pistol:

At 25.5 ft. ....820 ft per sec  
 At muzzle .....825 ft per sec

Submachine gun:

At 25.5 ft. ....885 ft per sec  
 At muzzle .....990 ft per sec

Muzzle energy:

In pistol .....329 ft-lb  
 In submachine gun.....383 ft-lb

**CARTRIDGE, Tracer, Cal. .45, M1.**

*General.* This cartridge was a standard item of issue for use in the Thompson Submachine Gun M1928A1 for observation of fire and incendiary purposes. It was also used for signal purposes in the automatic pistol. The M1 Cartridges have now been declared grade 3 and are not to be issued.

*Visual identification.* The cartridge is readily identified by its red tipped bullet, and the fact that the cartridge case has no cannelure.

*Components.* The cartridge consists of the cartridge case, primer, propelling charge, and bullet. The complete assembly weighs approximately 303 grains.

The bullet has a round nose and a cylindrical base. It consists of four parts: a gilding metal jacket, which is painted red for approximately  $\frac{3}{16}$  inch from the tip; a slug of lead hardened with antimony in the forward portion of the jacket; a tracer mixture in the central portion; and an igniter mixture in the rear portion. The over-all length of the bullet is 0.857 inch. The case may be crimped to the bullet and a pull of approximately 40 pounds is required to extract the bullet from the case.

Exterior ballistics, average maximum pressure. . . .18,000 lb per sq in.

Velocity, from submachine gun, at 25.5 ft. ....975 ft per sec

Range of trace.....200 yd

*Accuracy.* Fires within a mean radius of 8 inches at 100 yards.

**CARTRIDGE, Blank, Revolver, Cal. .45, M1.**

*General.* This cartridge is a current standard item of issue for use in the Colt, and Smith and Wesson, cal. .45 Revolvers M1917. It is

## SMALL ARMS AND TRENCH WARFARE

used for signaling purposes, firing salutes, training cavalry horses, and in maneuvers where simulated fire is desired. It is fired from the revolver without the use of clips, as the cartridge case has a rim for extracting purposes.

*Visual identification.* This cartridge is identified by the absence of a bullet.

*Components.* The cartridge consists of the cartridge case, primer propelling charge, and a paper wad. The complete assembly weighs approximately 123 grains.

The cartridge case differs from the standard cal. .45 cartridge case in that it is heavier and has a rim for extracting purposes.

The paper wad, inserted over the powder charge, is sealed in with a coat of varnish, and the mouth of the case is roll crimped to a diameter of  $\frac{5}{16}$  inch.

### CARTRIDGE, Dummy, Cal. .45, M1921.

*General.* This cartridge is a current standard item of issue and is used for training personnel in the operation of loading and unloading revolvers and to simulate firing. It is also used as a range dummy cartridge in the automatic pistol. In this latter case, it is mixed with live ammunition in pistol magazines, the purpose being to detect and correct flinching and faulty trigger squeeze.

*Visual identification.* This cartridge is identified by its tinned case which either has no primer or has holes drilled in the side of the case.

*Components.* The cartridge consists of a cartridge case, and a bullet. The complete assembly weighs approximately 313 grains.

The case of the earlier design contained three  $\frac{1}{8}$ -inch holes drilled in the body of the case, equally distant from each other, and an inert primer. In later design, the holes and the inert primer are omitted. Both cases are tinned for further identification.

The bullet is the same as that in the CARTRIDGE, ball, M1911.

### CARTRIDGE, High-pressure Test, Cal. .45, M1.

*General.* This cartridge is used for proof-firing cal. .45 weapons at the place of their manufacture. It contains a powder charge that will develop a breech pressure of approximately 20,000 pounds per square inch, this pressure being 4,000 pounds in excess of that required in cal. .45 service ammunition. Due to the danger involved in firing this cartridge, it should only be fired from a fixed rest under a hood, by means of a mechanical firing device, and only by authorized personnel.

*Visual identification.* It is readily identified by its tinned cartridge case.

AMMUNITION INSPECTION GUIDE

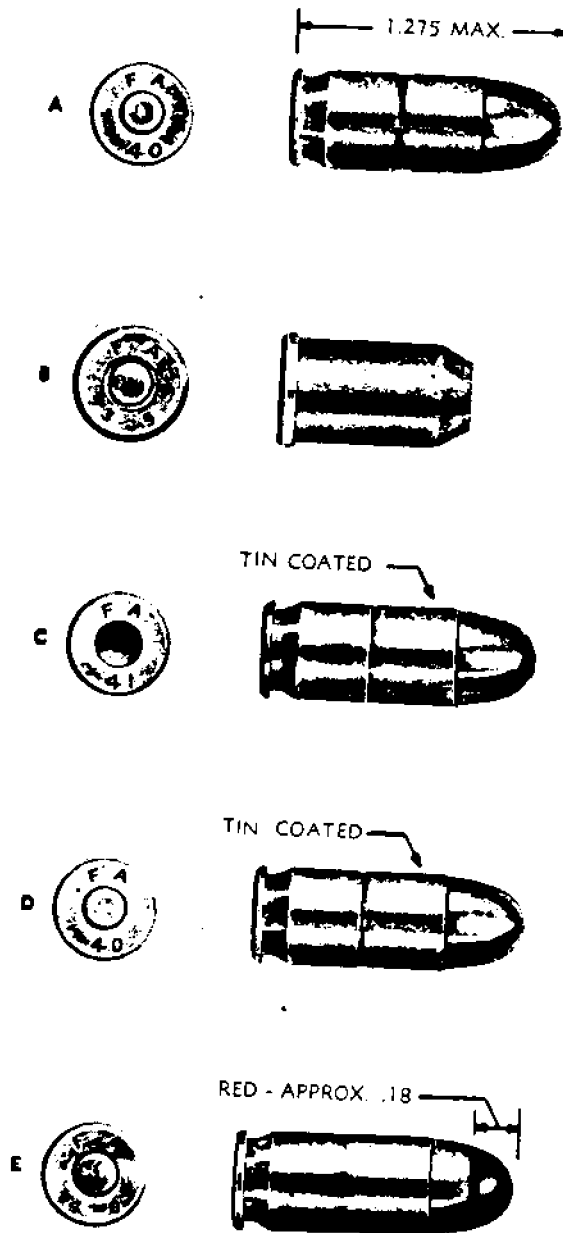

- A — CARTRIDGE, BALL, CAL. .45, M1911
- B — CARTRIDGE, BLANK, REVOLVER, CAL. .45, M1
- C — CARTRIDGE, DUMMY, CAL. .45, M1921
- D — CARTRIDGE, HIGH PRESSURE TEST, CAL. .45, M1
- E — CARTRIDGE, TRACER, CAL. .45, M1

RA PD 4525

Figure 81 — Cartridges, Cal. .45  
208

**SMALL ARMS AND TRENCH WARFARE**

*Components.* The cartridge consists of the cartridge case, primer, propelling charge, and bullet. The complete assembly weighs approximately 327 grains.

The bullet is the same as that in the CARTRIDGE, ball, M1911.

**AMMUNITION, CAL. .50.**

*General.* The ammunition described in this discussion is designed for use in all cal. .50 machine guns. It includes cartridges of the following types: ball, armor-piercing, tracer, incendiary, blank, dummy, and high-pressure test.

**CARTRIDGE, Ball, Cal. .50, M2.**

*General.* This cartridge is a standard cartridge for all cal. .50 machine guns.

*Visual identification.* This cartridge does not have any identification markings and the tip of the bullet is not painted.

*Components.* The cartridge consists of a cartridge case, primer, propelling charge, and bullet. The complete assembly weighs 1,800 grains.

The bullet consists of three parts; a gilding metal jacket, a soft steel core, and a point filler of lead hardened with antimony. The over-all length of the bullet is 2.29 inches. The base has a 9-degree taper, beginning at a point 0.386 inch from the base. The mouth of the case is crimped into the cannellure at assembly and a minimum pull of 100 pounds is required to extract the bullet from the case. Exterior ballistics, maximum range (approx.) . . . . . 7,200 yd

Velocity:

- At 78 ft. . . . . 2,900 ft per sec
- At muzzle . . . . . 2,935 ft per sec
- Maximum pressure . . . . . 52,000 lb per sq in.

*Accuracy.* At the time of acceptance, this ammunition will group within mean radii not greater than 8.0 inches at 500 yards, or 9.0 inches at 600 yards, when fired from an accuracy rifle held in a V-block.

**CARTRIDGE, Armor-piercing, Cal. .50, M2.**

*General.* This cartridge is a current standard item of issue for all cal. .50 machine guns. It is designed for use against armored aircraft, armored vehicles, concrete shelters, and similar bullet-resisting targets.

*Visual identification.* This cartridge may be identified by the blackened tip of the bullet.

*Components.* The cartridge consists of a cartridge case, primer, propelling charge, and bullet. The complete assembly weighs approximately 1,800 grains.

AMMUNITION INSPECTION GUIDE

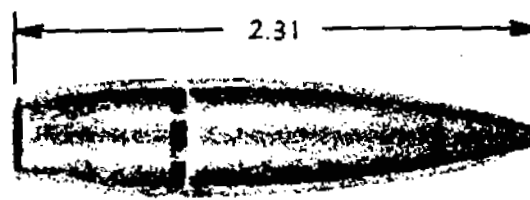

BULLET, BALL, CAL. .50, M2

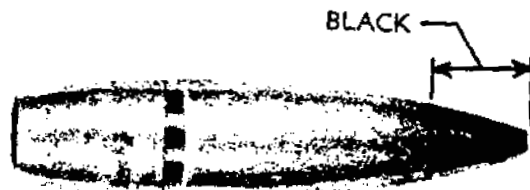

BULLET, ARMOR-PIERCING, CAL. .50, M2

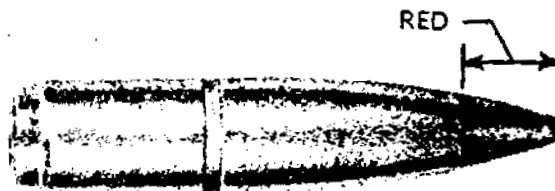

BULLET, TRACER, CAL. .50, M1

RA PD 4526

Figure 82a — Bullets, Cal. .50

The bullet consists of three parts: a gilding metal jacket; a tungsten-chrome steel core; and a point filler of lead hardened with antimony. The over-all length of the bullet is 2.29 inches and the point is blackened for approximately  $\frac{9}{16}$  inch. The base has a 9-degree taper beginning 0.386 inch from the base. The mouth of the case is crimped into the cannelure at assembly, and a minimum pull of 100 pounds is required to extract the bullet from the case.

Exterior ballistics, maximum range (approx.) . . . . . 7,200 yd  
 Maximum pressure . . . . . 52,000 lb per sq in.

Velocity:

At 78 ft. . . . . 2,900 ft per sec  
 At muzzle . . . . . 2,935 ft per sec

SMALL ARMS AND TRENCH WARFARE

- A-COMPOSITION, IGNITER
- B-COMPOSITION, SUB-IGNITER
- C-COMPOSITION, TRACER
- D-CORE-STEEL
- E-CORE-TUNGSTEN CHROME STEEL
- F-JACKET-GILDING METAL
- G-POINT FILLER-LEAD WITH ANTIMONY
- H-SLUG-LEAD WITH ANTIMONY

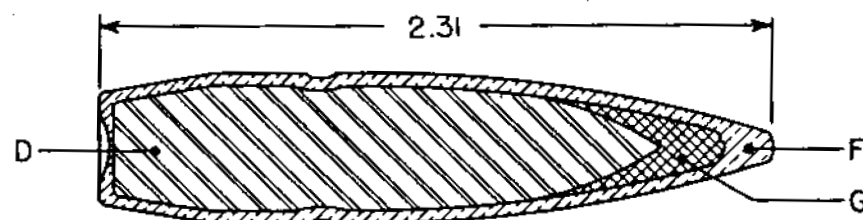

BULLET, BALL, CAL. .50, M2

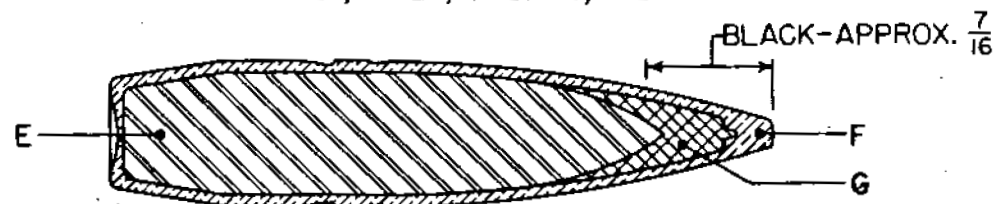

BULLET, ARMOR-PIERCING, CAL. .50, M2

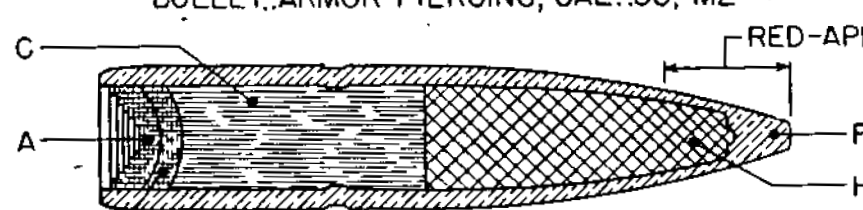

BULLET, TRACER, CAL. .50, M1

RA PD 4512

Figure 82b — Bullets, Cal. .50 — Sectioned



AMMUNITION INSPECTION GUIDE

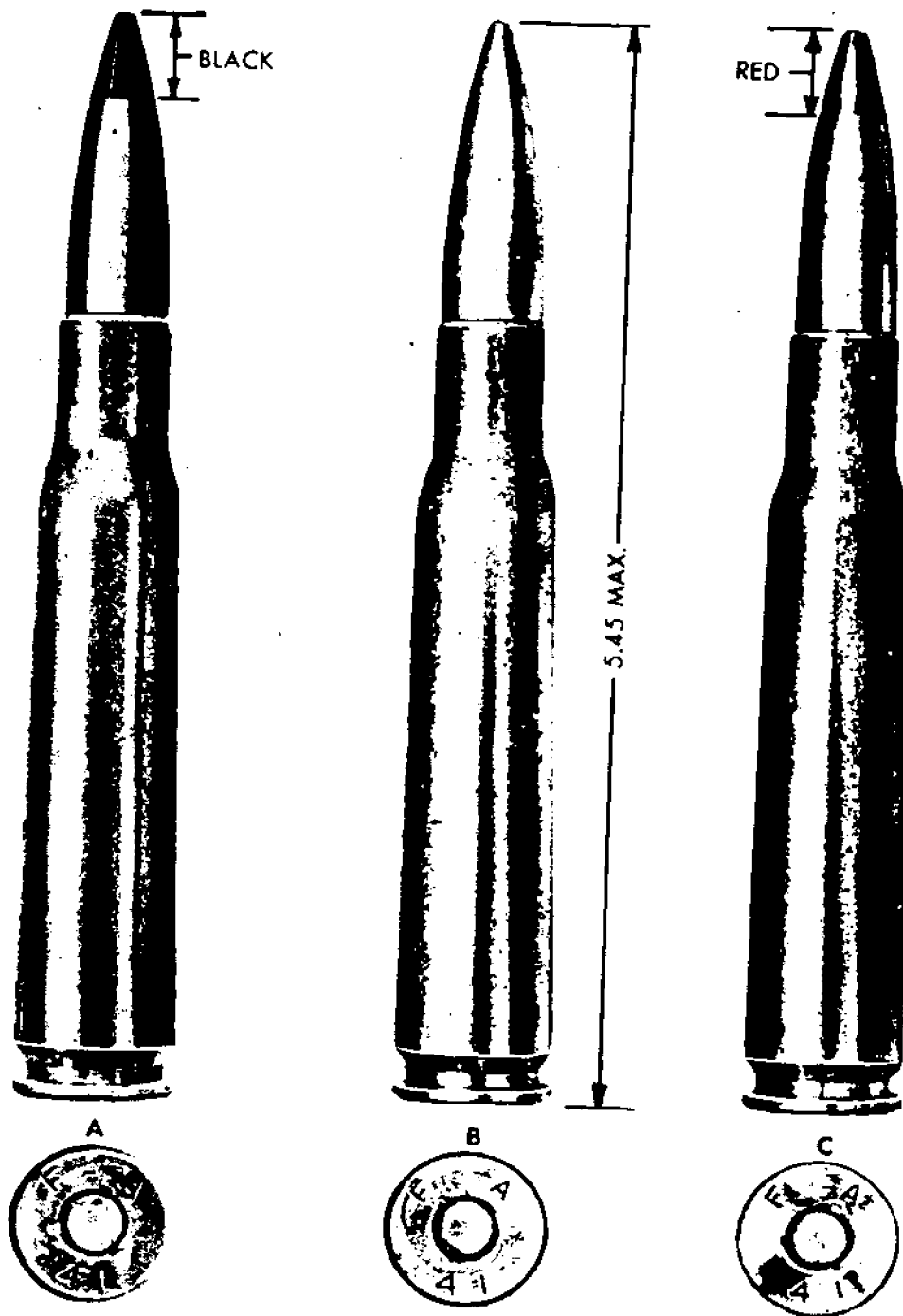

- A — CARTRIDGE, ARMOR-PIERCING CAL. .50, M2
- B — CARTRIDGE, BALL, CAL. .50, M2
- C — CARTRIDGE, TRACER, CAL. .50, M1

RA PD 2117

Figure 83 — Cartridges, Cal. .50

SMALL ARMS AND TRENCH WARFARE

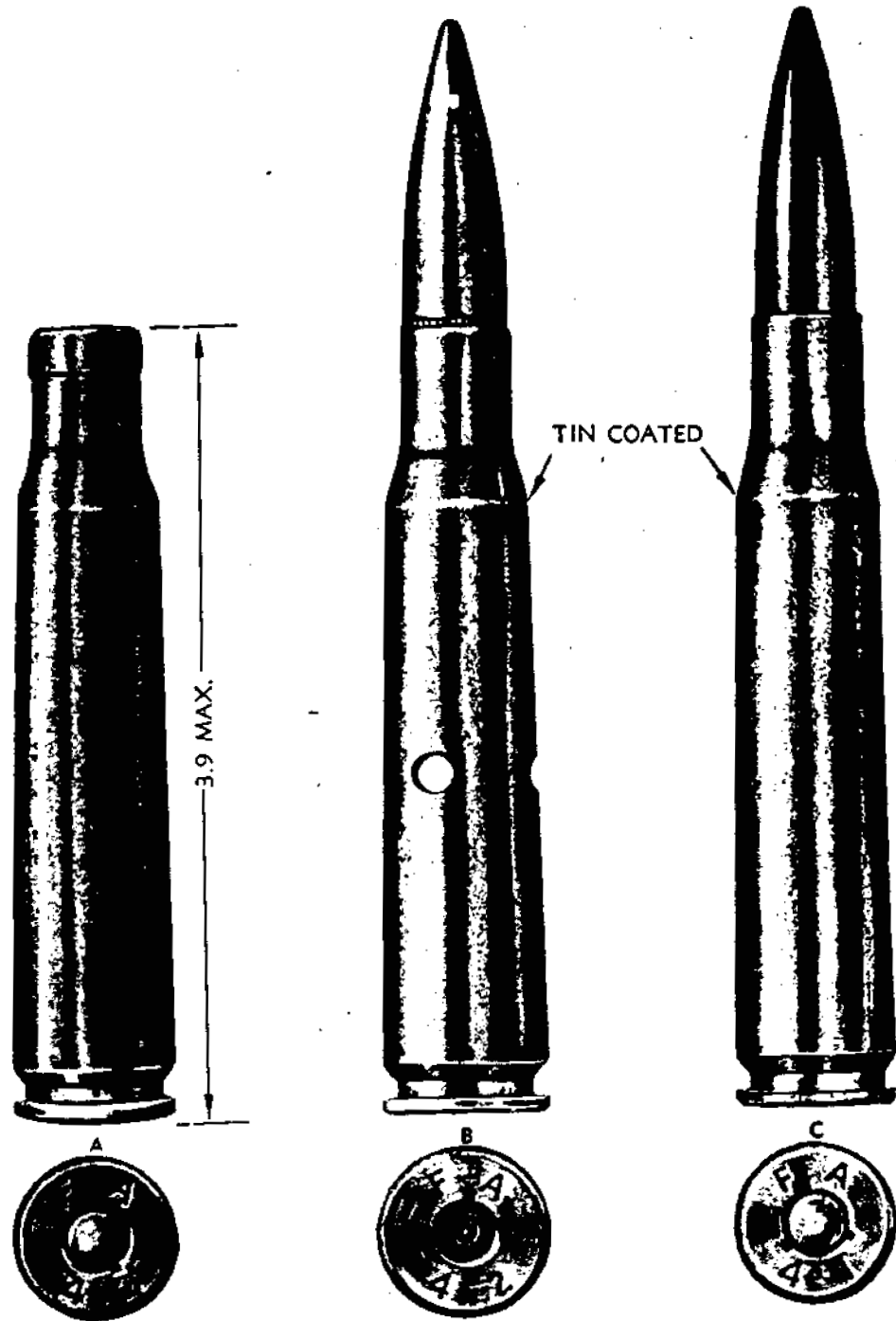

- A — CARTRIDGE, BLANK, CAL. .50, M1
- B — CARTRIDGE, DUMMY, CAL. .50, M2
- C — CARTRIDGE, HIGH PRESSURE TEST, CAL. .50, M1

RA PD 4530

Figure 84 — Cartridges, Cal. .50 — Continued

**AMMUNITION INSPECTION GUIDE**

*Accuracy.* At the time of acceptance, this ammunition will group within a mean radius not greater than 8.0 inches at 500 yards, or 9.0 inches at 600 yards.

**CARTRIDGE, Tracer, Cal. .50, M1.**

*General.* The cartridge is standard for observation of fire in all cal. .50 machine guns. It may also serve as an incendiary against balloons and other readily inflammable targets. Care must be exercised in the use of this cartridge to guard against its igniting dry vegetation on the range.

*Visual identification.* This cartridge may be distinguished by the point of the bullet, which is painted red to indicate the color of the trace.

*Components.* The cartridge consists of cartridge case, primer, propelling charge, and bullet. The complete assembly weighs approximately 1,760 grains.

The bullet consists of five parts: a gilding metal jacket; a hardened lead slug which fills the forward end of the jacket; a tracer composition which fills the central portion; an igniter; and subigniter composition, which fills the rear portion. Unlike the bullets for armor-piercing and ball cartridges, this bullet is cylindrical to the base. The base is open to permit the propelling charge to ignite the tracer composition. The over-all length of the bullet is 2.4 inches. The mouth of the case is crimped into the cannelure at assembly, and a minimum pull of 100 pounds is required to extract the bullet from the case.

Exterior ballistics, maximum range:

Bullet ..... 3,500 yd  
 Trace.....The trace begins at a distance not greater than 250 feet from the weapon; the range of the trace is about 1,600 yards.

Maximum pressure ..... 52,000 lb per sq in.

Velocity:

At 78 ft. .... 2,830 ft per sec  
 At muzzle ..... 2,865 ft per sec

*Accuracy.* At the time of acceptance, this ammunition will group within a mean radii not greater than 20 inches at 600 yards.

**CARTRIDGE, Incendiary, Cal. .50, M1.**

*General.* This cartridge is a standard item of issue for use in cal. .50 machine guns.

*Visual identification.* The cartridge resembles the CARTRIDGE, ball, cal. .50, M2, in outward appearance, but it may be identified by the light-blue paint on the tip of the bullet.

## SMALL ARMS AND TRENCH WARFARE

*Components.* The cartridge consists of a cartridge case, primer, propelling charge, and bullet.

The bullet consists of four parts: a gilding metal jacket; a hollow steel cylindrical core; an incendiary composition; and a lead base filler. The mouth of the cartridge case is crimped into the knurled cannellure at assembly, and a minimum pull of 100 pounds is required to remove the bullet from the case.

Exterior ballistics—This information is not available at this time.

### **CARTRIDGE, Blank, Cal. .50, M1.**

*General.* The CARTRIDGE, blank, cal. .50, M1, is a standard item of issue designed for use in cal. .50 machine guns with a blank firing attachment in order to operate the weapon for training purposes.

*Visual identification.* This cartridge is identified by the absence of a bullet.

*Components.* This cartridge consists of a cartridge case, primer, propelling charge, and wad.

The case has a slight annular groove about  $\frac{1}{4}$  inch from the mouth, which serves as a seat for the wad.

The wad is a disc punched out of strawboard sheet,  $\frac{1}{16}$  inch thick, and is lacquered on both sides before the blanking operation.

The powder charge consists of 43 grains of E. C. Blank Fire Powder. After loading, a heavy coat of lacquer is applied to the wad and the mouth is crimped.

### **CARTRIDGE, Dummy, Cal. .50, M2.**

*General.* This cartridge is standard for use in all cal. .50 machine guns for training purposes. It may also be used for testing the mechanism of the gun.

*Visual identification.* This cartridge is distinguished from live ammunition by the cartridge case, which is tin-coated, has three holes drilled in the side and an empty primer pocket. It is distinguished from the CARTRIDGE, dummy, cal. .50, M1, by the bullet which is tin-coated.

*Components.* This cartridge consists of a cartridge case, and a bullet.

The cartridge case is identical with service cases except, as noted above, it is tin-coated and has three holes drilled about the midpoint.

The bullet consists of three parts: a tin-coated gilding metal jacket, a soft steel core, and a point filler of hardened lead. The mouth of the case is crimped into the cannellure at assembly, and a minimum pull of 100 pounds is required to extract the bullet from the case.

**AMMUNITION INSPECTION GUIDE**

Cartridge Cal. .50	Status	Primer Cup	Cartridge Case	Ogive	Base
BALL M2	S&M	Brass	Brass	Pointed	Tapered
TRACER M1	S&M	Brass	Brass	Pointed	Square
ARMOR-PIERCING M2	S&M	Brass	Brass	Pointed	Tapered
INCENDIARY M1	S&M	Brass	Brass	Pointed	Tapered
DUMMY M2	S&M		Brass(tinned) 3 Holes	Pointed	Tapered
BLANK M1	S	Brass	Brass		
HIGH-PRESSURE TEST M1		Brass	Brass(tinned) "TEST" on head	Pointed	Square

Cartridge Cal. .45	Status	Primer Cup	Cartridge Case	Ogive	Base
BALL M1911	S&M	Gilding Metal	Brass	Rounded	Square
TRACER M1	S&M	Gilding Metal	Brass	Rounded	Square
DUMMY M1921	S&M	Inert None	3 Holes* No Holes*	Rounded	Square
BLANK M1	S&M	Gilding Metal	Brass Has extract- ing flange		
HIGH-PRESSURE TEST M1		Gilding Metal	Brass(tinned) "TEST" on head	Rounded	Square

## SMALL ARMS AND TRENCH WARFARE

BULLET				REMARKS
Jacket	Point Filler	Core	Base Filler	
Gilding Metal	Lead Antimony	Soft Steel		
Gilding Metal	Lead Antimony	Tracer Mixture	Igniter Subigniter	Tip of bullet painted red
Gilding Metal	Lead Antimony	Tungsten Chrome Steel		Tip of bullet painted black
Gilding Metal		Incendiary Mixture		Tip of bullet painted blue
Gilding Metal (tinned)	Lead Antimony	Soft Steel		
Gilding Metal		Lead Slug in two parts		Used to test for breech pressure Not issued to troops

BULLET				REMARKS
Jacket	Point Filler	Core	Base Filler	
Gilding Metal		Lead Antimony		Old jackets—cupronickel Next jackets—gilding metal—tinned Present jackets—gilding metal
Gilding Metal	Lead Antimony	Tracer Mixture	Igniter	Tip of bullet painted red Used in submachine gun
Gilding Metal		Lead Antimony		*Cartridge case is brass (tinned)
				Fired in revolvers only
Gilding Metal		Lead Antimony		Used to test for breech pressure Not issued to troops

**AMMUNITION INSPECTION GUIDE****CARTRIDGE, High-pressure Test, Cal. .50, M1.**

*General.* The CARTRIDGE, high-pressure test, cal. .50, M1, is used for proof-firing cal. .50 machine guns at the place of manufacture. The cartridge is loaded with a powder charge sufficient to develop a breech pressure averaging 62,500 pounds per square inch for any 10 consecutive shots. Due to this excessive pressure and the danger involved in firing, the guns under test are fired from a fixed rest under a hood by means of a mechanical firing device. This cartridge should be fired only by authorized personnel.

*Visual identification.* This cartridge is distinguished from other cal. .50 cartridges by the tinned cartridge case. Dummy cartridges, which also have tinned cartridge cases, have holes drilled through the case.

*Components.* The cartridge consists of a cartridge case, primer, propelling charge, and bullet. The entire assembly weighs 1,980 grains.

The case is made of tinned cartridge brass; in other respects it is the same as the cases of other cartridges of this caliber.

The bullet consists of a gilding metal jacket and a core made up of two slugs, a front slug and a rear slug. The mouth of the case is crimped into the cannelure at assembly and a minimum pull of 100 pounds is required to extract the bullet from the case.

**AMMUNITION, MISCELLANEOUS.****CARTRIDGE, Ball, Cal. .22, Long Rifle.**

*General.* This cartridge has superseded the CARTRIDGE, cal. .30 gallery practice, M1919, and is used in the cal. .22 U. S. Rifles M1922, M1922MI, and M2, and in cal. .22 machine guns, machine-gun trainers, and pistols for gallery practice and training purposes.

*Visual identification.* Containers of this ammunition are marked by the manufacturer with the caliber, type, and such trade names as "Kleanbore," "Lubaloy," "Rustless," "Tackhole," "Copperhead," etc. Cal. .22 ammunition has the manufacturer's lot number stamped on the wooden packing box. This provides a means of identifying and reporting any ammunition of this type which may become defective.

*Components.* These cartridges are purchased by the Ordnance Department from several commercial manufacturers. They are all of the same general appearance, but differ slightly in the shape of bullet, powder used, and ballistic qualities. The cartridge, complete, weighs approximately 53 grains. It consists of cartridge case, priming composition, propelling charge, and bullet. The cartridge case is made of brass or gilding metal, and is of the rim-fire type; that is, the priming composition is spun into a circular recess inside the rim instead of being seated in the center of the case head as a separate component. A blow from the firing pin at any position on the rim

## SMALL ARMS AND TRENCH WARFARE

compresses the priming composition causing it to explode and ignite the powder charge. The priming composition and charge of smokeless powder may differ for each manufacturer. Cal. .22 long rifle ammunition contains a noncorrosive, nonmercuric primer composition. The type of powder used is usually marked on the containers, and the charge weighs approximately 1.7 grains. The bullet is made of lead. Bullets of different manufacture differ slightly in shape, but all weigh approximately 40 grains.

*Exterior ballistics.* Cal. .22 long rifle cartridges of different manufacture vary somewhat in velocity and pressure. The following data are approximate:

Maximum range, with the piece elevated at an angle in order of 30 degrees.....	1,500 yd
Average muzzle velocity.....	1,100 ft per sec
Average pressure.....	16,000 lb per sq in.

### CARTRIDGE, Subcaliber, Cal. .30.

*General.* The cal. .30 cartridge, subcaliber is designed for firing from the subcaliber tube of the 3-inch (15 pdr.) seacoast gun. Its use for subcaliber practice with other types of cannon has been discontinued. There are two types of cal. .30 subcaliber cartridges: the CARTRIDGE, subcaliber, cal. .30, M1925; and the cal. .30, subcaliber, cartridge old stock. Both types of cal. .30 subcaliber cartridges are limited standard; the old stock on hand is given priority of issue. Under no circumstances may the cal. .30, subcaliber, cartridge be used in other than "Krag" type rifle barrel chambers.

*Visual identification.* Subcaliber cartridges are distinguished from other cal. .30 types by the presence of an extracting rim on the cartridge case.

*Components.* This cartridge consists of cartridge case, primer, propelling charge, and bullet.

The cartridge case differs from that of other cal. .30 types, in that it has an extracting rim instead of a groove.

The primer is assembled in a monel metal primer cup in order that it may function without being punctured on the heavy blow of a gun firing pin, and still function properly on the light blow of a rifle firing pin.

The propelling charge consists of approximately 35 grains of pyro D. G. powder.

The bullet of the old style cartridge is cylindrical, with a round nose; the jacket is cupronickel; the filler, hardened lead. The bullet of the M1925 is boat-tailed and pointed; the jacket is gilding metal.

Exterior ballistics, maximum range.....	4,300 yd
Muzzle velocity.....	2,025 ft per sec
Average maximum pressure.....	40,000 lb per sq in.



**AMMUNITION INSPECTION GUIDE**

**CARTRIDGE, Carbine, Cal. .30, M1.**

*General.* This cartridge is a current standard item of issue for use in the CARBINE, cal. .30, M1.

*Visual identification.* This cartridge can be readily identified by its characteristic shape.

*Components.* The cartridge consists of a cartridge case, primer, propelling charge, and bullet. The complete assembly weighs 195 grains. The cartridge case has a slight taper throughout its length. The bullet consists of two parts; a lead alloy core, and the jacket. The bullet weighs 110 grains.

Exterior ballistics, maximum pressure.....31,000 lb per sq in.  
Velocity:

At 53 ft.....1,900 ft per sec

At muzzle.....2,000 ft per sec

*Accuracy.* When test fired, it will group within a mean radius of 4 inches at 300 feet.

**SHELL, Shotgun, 12-gage.**

*General.* Shotgun shells are procured by the Ordnance Department from several manufacturers for use in 12-gage sporting and riot-type shotguns. They are intended for guard or combat use and for hunting or trap shooting.

*Visual identification.* Shells for guard and combat use have a brass head extending at least 1 inch along the case. Shells for sporting use have a head extending only 1/2 inch along the case.

*Components.* The shell consists of a case, a primer, several wads, a propelling charge, and a load of lead shot.

The case consists of a brass head and a paper case or shell body. In guard or combat shells, the head extends a distance of 1 inch along the case. (In some shells, the entire case is of brass.) In sporting shells, the head extends 1/2 inch. The head is reinforced by a base of compressed paper in which the primer pocket is formed. Some paper shells have a steel reinforcement, called the lining, under the brass head. The shell body is made of paper and waterproofed. The head is attached to the shell body by crimping.

The primer is a commercial type suitable for ignition of the smokeless powder used.

The size of the leadshot for each type is as follows:

Guard or combat.....	No. 00 buckshot
	No. 4 chilled shot
Sporting.....	No. 7 1/2 chilled shot
	No. 9 chilled shot

The arrangement of the wads (paper and felt) is shown in the illustration.

**SMALL ARMS AND TRENCH WARFARE**



CARTRIDGE, BLANK, CAL. .22, FIELD ARTILLERY TRAINER, M2 AND M2A1



CARTRIDGE, BALL, CAL. .22, LONG RIFLE RA PD 4531

**Figure 85a — Cartridges, Cal. .22**

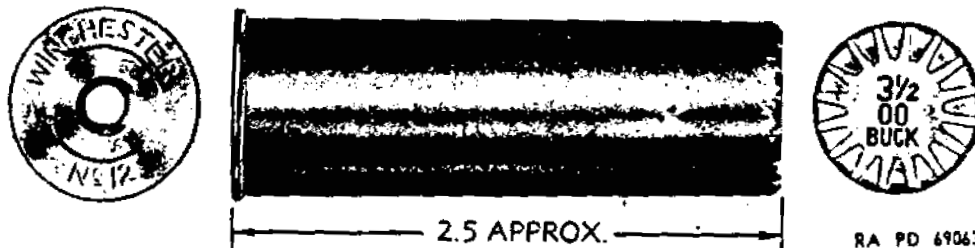

RA PD 69063

**Figure 85b — SHELL, Shotgun, 12-gauge**

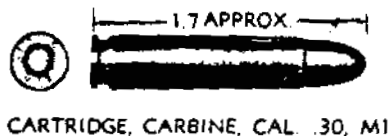

CARTRIDGE, CARBINE, CAL. .30, M1



CARTRIDGE, SUBCALIBER, CAL. .30, M1925

RA PD 4532

**Figure 85c — Miscellaneous Cartridges**

**PACKING.**

**Packing Boxes.** Standard wooden packing boxes are illustrated in figure 86. The outer wooden cover of the box is held in place by six wing nuts. Some boxes have watertight, metal liners. The cover of these liners is closed by soldering but can readily be torn or ripped off by use of a wire handle provided for this purpose.

Due to the current shortage of metal, other forms of liners are being used in place of the metal liners in some packing boxes. A liner made of paraffin-coated cardboard is used in some instances. This liner is but one-half the length of the metal liner, and two are required to a wooden packing box.

Another substitute for the metal liner is the use of packing envelopes. These are used for cal. .30 rounds, when linked in the 100-

## AMMUNITION INSPECTION GUIDE

round link belts. The envelope is made of paper with a metal foil liner. Twelve of these envelopes are used to a wooden packing box.

An all metal packing box is also used for some packings. This metal box holds one machine gun belt (250 rounds) and four of these boxes are packed in wire-bound crate.

**Within Boxes—Cal. .30.** For cal. .30, the following packings are found within the wooden packing box:

1. Cartons (20 rounds per carton).
2. Clips in cartons (5 rounds per clip, 4 clips per carton).
3. Clips in bandoleers (5 rounds per clip, 2 clips per pocket, 6 pockets per bandoleer; or 8 rounds per clip, 1 clip per pocket, 6 pockets per bandoleer).
4. Machine gun (web) belts (250-round belt).
5. Metallic link belts (100-round belt).

**Within Boxes—Cal. .50.** For cal. .50, the following packings are found within the wooden packing box:

1. Cartons (10 rounds per carton).
2. Metallic link belts (265 rounds per link belt).

**Within Boxes—Cal. .45.** For cal. .45, the following packings are found within the wooden packing box:

1. Cartons (20 rounds per carton).
2. Cartons (50 rounds per carton).

**Within Boxes—Cal. .22.** For cal. .22, the following packings are found within the wooden packing box:

1. Boxes within cartons (50 rounds per cardboard box, 10 boxes per carton, 20 cartons per wooden box).

### MARKING.

**General.** The marking of small-arms packing boxes is divided into two groups: the older method; which covered cal. .30, cal. .45, and cal. .50 cartridges in all packings; and the modified method; which covers cal. .30 and cal. .50 cartridges when packed in clips, link belts, and web belts. In both methods, the boxes are painted chocolate brown and the stencil is in yellow.

**Older Method.** To provide a means of identification as to type and caliber, small-arms packing boxes were marked with color bands. On boxes for cal. .30 and cal. .45 cartridges, the band is painted vertically on the sides and horizontally on the ends. On boxes for cal. .50 cartridges, the bands are painted diagonally on ends and sides. Prior to 1933, the band was also painted across the top. Cal. .45 may be distinguished from cal. .30 by the size of the box (cal. .45 is

223

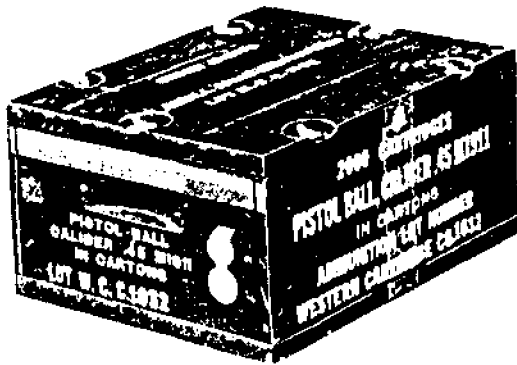
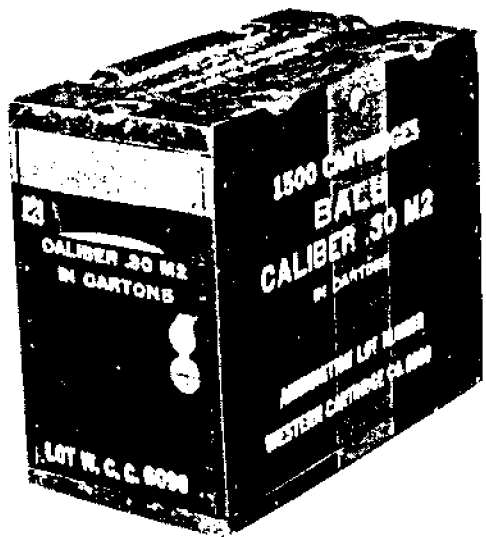

RA PD 4014

SMALL ARMS AND TRENCH WARFARE

TM 9-1904

Figure 86 — Color Band Marking for Small-arms Packing Boxes

D-6a

AMMUNITION INSPECTION GUIDE

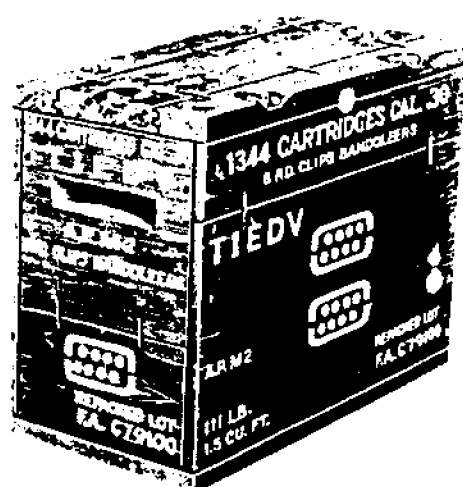

8-RD. CLIPPED

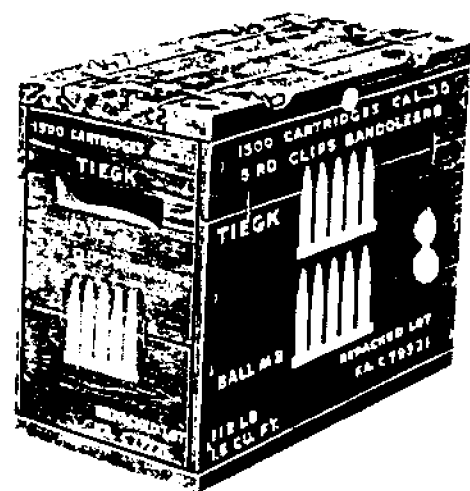

5-RD. CLIPPED

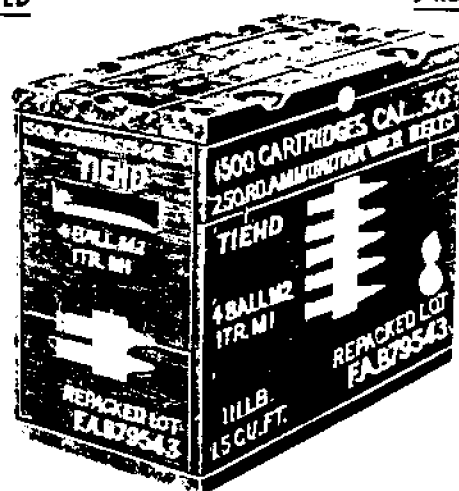

CAL. .30 BELTED

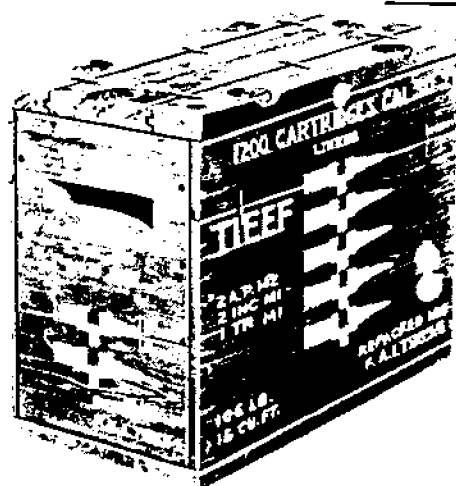

CAL. .30 LINKED



CAL. .50 LINKED

RA PD 15193A

Figure 87 — Symbol Marking for Small-arms Packing Boxes

**SMALL ARMS AND TRENCH WARFARE**

smaller) and by the band which is one-half the width, for cal. .45 of that used for cal. .30.

The following color bands were used for each type:

<b>Type</b>	<b>Band</b>
Ball .....	Red
Blank .....	Blue
Dummy .....	Green
Gallery practice .....	Brown
Guard .....	Orange
High-pressure test .....	Yellow
Armor-piercing.....	Blue on yellow
Tracer.....	Green on yellow
Incendiary.....	Red on yellow
Rifle grenade.....	2 Blue bands

While this method has been superseded by the modified method for certain packings (clips, link belts, and web belts), those boxes already marked with the bands will not be changed, and rounds which do not come under the provisions of the modified method continue to use the appropriate bands.

In addition to color bands, each box of ammunition is marked with complete information necessary for shipping, care, handling, and use.

**Modified Method.** In this method, symbols representing the method of packing within the box (clips, link belts, web belts) are stenciled on the box. These symbols are vertical, on the side and end, for cal. .30 ammunition, and diagonal, on the side and end, for cal. .50 ammunition. Color bands, formerly used to indicate the type of cartridges in the box, are replaced by markings stenciled on the box indicating the type, or types and ratio, of ammunition within the box, for example:

"4 BALL M2, 1 TR M1"

Aside from the changes noted above, the packing boxes are marked in the same manner as previously.

In view of the fact that both methods are now in service, it is to the ammunition inspector's advantage to be familiar with both methods.

**SURVEILLANCE.**

**General.** Surveillance includes, in part, the observation, inspection, investigation, and test of explosives and ammunition both in storage and in use. The Chief of Ordnance exercises general supervision over the surveillance of explosives and ammunition, prescribes the tests, and maintains the records of the condition of all lots in service and in storage.

**Description of Tests.** Tests to which small-arms ammunition is subjected for acceptance and, subsequently, for surveillance and grad-

## AMMUNITION INSPECTION GUIDE

ing are visual examination; velocity test; pressure test; functioning and casualty tests in specified weapons; hang-fire test; bolt-lift test; accuracy test; tracer test; loading and unloading test. Some of these tests are described below.

*Visual inspection.* Examination of sample for season cracks, corrosion, or other visual defects.

*Velocity test.* Standard methods are used for conducting velocity tests. Screens are placed a definite distance apart and the velocity of the bullet is calculated from the time of flight in traveling from the first screen to the second. In the Boulenge test, the first screen is placed 3 feet from the gun muzzle and the second screen is placed 150 feet from the first. The velocity determined from the time of flight between the two screens is the velocity at 78 feet from the muzzle. A modification of the above test, where distance is not available, requires the screens to be spaced 100 feet apart, and the calculated velocity is the velocity at 53 feet from the muzzle of the gun. Other modifications of the test are to ascertain the velocities at the same average distance from the muzzle of the gun.

*Pressure test.* This test is conducted in a pressure barrel. The barrel has a small hole drilled in the side of the chamber into which is inserted a small piston. On firing the cartridge, the pressure of the gases forces the piston against a copper cylinder and compresses it. The amount of compression of the cylinder is the index of the pressure developed.

*Hang-fire test.* In this test, the cartridges are fired in a machine gun at a disc revolving at a prescribed speed. By means of a mechanical device the gun is synchronized with the disc; that is, the gun is mechanically timed to fire at a given point on the disc each time it makes a complete revolution. A small group of holes is produced on the disc, which must not exceed 15 degrees for grade AC ammunition, nor 28 degrees for other grades, when the disc speed is 1,800 revolutions per minute.

*Machine gun functioning test.* A number of cartridges are fired in a machine gun to determine the number of jams, ruptures, or other mechanical defects.

*Rifle functioning tests.* A number of rounds are fired in a rifle whose head space is specified.

*Tracer test.* Tracer ammunition is given a tracer test in which the ammunition is fired in a machine gun. The number of shots failing to trace the required distance and the number of muzzle bursts, blinds, or other erratics are recorded.

*Defects found on visual examination.* The following defects may be found in cartridges during examination:

**SMALL ARMS AND TRENCH WARFARE**

*Season crack.* A split in the neck of the cartridge case. Working the metal in the drawing and tapering operations in the manufacture of the cartridge case produces internal stresses or strains due to distortion of the normal crystalline structure. This condition is further aggravated by the insertion of the bullet. Rearrangement of the crystalline structure leads to failure of the metal along definite longitudinal lines of least resistance. This is known as season cracking. Exposure to severe weathering conditions or certain reagents hastens the time of cracking. In order to prevent or decrease the tendency to season crack, a final anneal is applied to the neck of the cartridge case. This annealing allows the crystals to rearrange themselves in their natural state without the metal cracking. In reporting season crack in ammunition, care should be taken not to confuse this defect with that known as "split necks" which occur when the ammunition is fired.

*Corrosion.* There are varied stages of corrosion. The minor stages do not necessarily raise the surface of the metal, but are more in the nature of a harmless discoloration of the cartridge case. An examination of the case should indicate whether the corrosion has eaten into and weakened the metal to such an extent that it may cause rupture when the cartridge is fired. True discoloration is the blackening of the cartridge case, whereas corrosion adds other colors such as green, red, yellow, blue, and white. Corrosion in the advance stages, through some chemical action, appears to deposit a substance on the case which will interfere with chambering the cartridge. In reporting corrosion, the degree of corrosion should be described. Discoloration is really of minor importance since ammunition that is only discolored will function as well as good ammunition. Advanced corrosion, however, is a serious defect and ammunition thus affected should not be fired. The use of steel wool or other abrasives to remove corrosion from cartridge cases is prohibited.

*Mouth pulled down.* This defect would be attributed to the fact that the mouth of the cartridge case was not concentric, and when the bullet was seated it struck one side of the mouth of the cartridge case and shoved the metal down. This defect occurs much more frequently with a cartridge case whose mouth is annealed very soft, than with a cartridge case whose mouth has no, or a very slight, anneal. It is also possible that this defect may be caused by improper alignment of the bullet loading machine.

*Shoulder bulge.* A pucker in the metal of the cartridge case at the junction of the shoulder and body. This defect is generally caused by the metal at that point being either too thin or too soft. It is also caused by a maximum diameter bullet being seated in a cartridge case having a neck of minimum diameter.

*Oil dent.* A smooth-surfaced indent in the cartridge case generally



## AMMUNITION INSPECTION GUIDE

in or near the shoulder or neck. This defect is caused by an excess of oil used in the tapering operation. Unless extremely large, so as to greatly increase the density of loading, thereby increasing the pressure, this defect is negligible.

*Draw scratch.* A longitudinal scratch, varying in degree, on the cartridge case. This defect is caused by grit or some other foreign material in the final draw die and is due to the improper washing of the material before reaching that operation. A cartridge having a deep draw scratch will probably open up on firing with a consequent loss in velocity. Also cartridge cases containing this defect will probably split in storage sooner than normal cartridge cases.

*Split mouth.* A split in the edge of the cartridge case. This defect is caused by the plugging operation.

*Folded neck.* Overlapping of metal in the neck of a cartridge case indicated by a longitudinal protuberance on the outside. This defect is caused by the metal in the neck of the cartridge case being thinner on one side than on the other and by insufficient annealing.

*Scale.* Inclusions of impurities in the metal which are sometimes hidden. If hidden, and not discovered by the inspectors, it often causes an irregular break in the cartridge case and loss of velocity due to the escape of gas when fired. This defect is inherent in the metal and is not caused by faulty manufacture. Scaly metal shortens the life of the cartridge-making tools considerably.

*Indent and bur.* These defects generally arise from rough handling of the cartridge cases during the process of manufacture. If cartridges with these defects chamber in the rifle, there is no danger in using them, unless the dent is so large that the density of loading is increased to such an extent that a dangerous pressure would result.

*Crease.* This is very similar to a fold, and generally occurs in the neck or shoulder of the cartridge case. It is caused by thin metal.

*Thick head.* The head of the cartridge case has a thickness of metal greater than the maximum allowed. This defect generally occurs during the adjustment of the head-trimming machine. It is also sometimes caused by a chip of metal getting on the push-in feed rod, thereby causing a cartridge case to be improperly chucked. Such a defect will probably give trouble in extraction, as the extractor is not able to function with an extremely large head.

*Thin head.* The head of the cartridge case has a thickness of metal less than the minimum allowed. This defect happens during the adjustment of the head-trimming machine. It will be the probable cause of the extractor failing to function because it pulls through the thin metal of the head and does not extract the case.

*Round head.* The head of the cartridge case which is beveled on the outer edge so that it is practically round. This defect is generally

SMALL ARMS AND TRENCH WARFARE

LOCATION OF SPLITS

- A - MOUTH
- B - BETWEEN MOUTH AND BULLET SEAT CANNELURE
- C - IN SIDEWALL NEAR HEAD
- D - IN SIDEWALL EXTENDING INTO EXTRACTION GROOVE
- E - IN SIDEWALL EXTENDING INTO PRIMER POCKET
- F - IN SIDEWALL OF SHOULDER

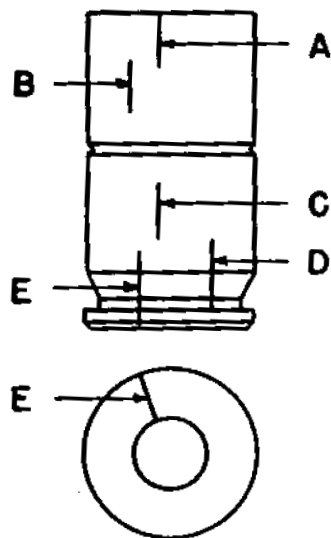

CAL. .45, M1911

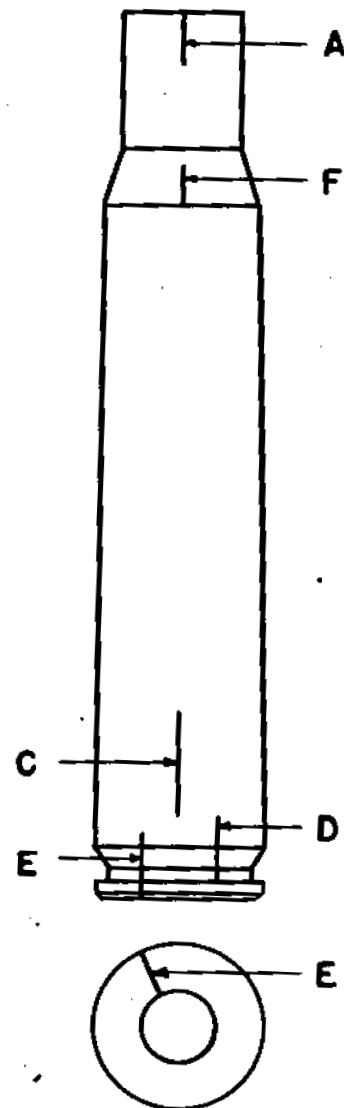

CAL. .30 & CAL. .50  
RA PD 4520

Figure 88 — Location of Splits in Cartridge Cases

found in a case which has been pocketed but not headed. It sometimes happens with a thin case which contains too little metal in the head to properly form it. This defect causes trouble in extraction. At times a thick-headed cartridge, on account of the bevel given it, has an appearance of a round head.

*Split bullets (tracer ammunition).* Longitudinal cracks in the bullet which often rupture the neck of the cartridge case. In most cases, this is due to impure tracer mixture which either has absorbed too much moisture or liberated free mercury which amalgamates with the

## AMMUNITION INSPECTION GUIDE

metal of the bullet causing the split. This defect is very serious and when found should be immediately reported.

**Defects Found After Firing.**

*Misfire (heavy blow).* The primer shows an impression of the firing pin which indicates that a blow sufficiently hard to ignite a perfect primer has been delivered. Such a misfire as described indicates that the primer is defective. The defect may be from:

1. Thick metal in the base of the primer cup.
2. Thick primer pellet which cushions the blow.
3. No priming pellet in the primer.
4. No primer pellet mixture between the primer cup and anvil.
5. No anvil.
6. No vent hole.
7. Various combinations of these defects.

*Misfire (light blow).* The primer is so lightly marked by the impression of the firing pin that it indicates that the force of the blow struck was not sufficient to ignite the primer. This may be caused by:

1. A mechanical defect in the weapon.
2. A short or broken firing pin.
3. A weak firing pin spring.
4. The bolt of the weapon not completely locked.
5. Grease in the firing pin hole which cushions the blow of the firing pin.
6. Primer seated too deep in the primer pocket.
7. Improper angle of the shoulder of the cartridge case which allows the cartridge case to go forward.

*Hangfire.* Delayed ignition of the powder in the cartridge may be caused by a small or decomposed primer pellet, damp powder, or a light blow of the firing pin caused by dirt or a defect in the weapon. While a hangfire is a serious defect if the delay is long enough to permit the bolt to be opened before the powder burns completely, such a delay is rarely found in practice. Should a hangfire of several seconds delay occur, and the bolt be opened before the powder explodes, injury to the firer or damage to the weapon, or both, may result.

*Pierced primer.* Perforation of the primer cup by the firing pin. This may be caused by an imperfect pin or very thin metal in the base of the primer cup. There are various degrees of this perforation. A very small perforation will show, by means of a discoloration around the indent made by the firing pin, the escape of gas. The disc from a large perforation may be blown into the action of the gun with such an escape of gas as to lower the velocity of the bullet.

## SMALL ARMS AND TRENCH WARFARE

*Primer leak.* Gas generated by the explosion of the powder charge escapes between the walls of the primer cup and the primer pocket, causing discoloration around the primer and the head of the cartridge case. The discoloration may be slight, indicating a small primer leak; or heavy, indicating a large primer leak. The primer leak may be because of too small a primer, too large a primer hole, or excessive pressure generated by the propelling charge.

*Blown primer.* On firing the cartridge, the primer is blown completely from the pocket of the cartridge case. Although this is a serious defect, it is seldom encountered.

*Primer set-back.* Pressure developed by the explosion of the propellant charge forces the primer back against the face of the bolt. On examination, it will be seen that the primer protrudes above the head of the cartridge case. The set-back of the primer may be slight or heavy and is due to a defective bolt, cartridge, or excessive pressure.

*Leak at back of case.* The gas escapes into the action of the weapon. The discoloration due to this escape of gas is along the body of the cartridge case.

*Failure of case to extract.* This may be due to a poorly formed or weak extractor, or a defective cartridge.

*Blowback.* An escape of gas under pressure to the rear is commonly referred to as a blowback. Pierced primer, primer leak, blown primer, primer set-back, and ruptured cartridge, are known as blowbacks.

*Split neck.* The neck of the cartridge case splits in firing and is accompanied by an escape of gas. This should not be confused with a split neck due to season cracking which can be observed before firing.

*Split body.* A more or less regular longitudinal split in the body of the case which allows gas to escape, thereby reducing the velocity of the bullet. This defect is generally found in cartridge cases which have a deep draw scratch or in those which are made from defective brass.

### CARE, HANDLING, AND PRESERVATION.

*General.* The provisions contained in this section are of a specific nature for small-arms ammunition only.

#### Care and Precautions in Handling.

*Boxes.* Small-arms ammunition, as compared with other types of ammunition, is not dangerous to handle. Care, however, must be observed to keep the boxes from becoming broken or damaged. All broken boxes must be repaired immediately. All markings should be transferred to the new parts of the box. The metal liner should be air-tested and sealed if equipment for this work is available.

## AMMUNITION INSPECTION GUIDE

Boxes should always be opened by breaking the seals and unscrewing the wing nuts. They should be opened carefully, as the wooden boxes are used as long as they are serviceable. If the cover of the metal liner sticks, it may be loosened by placing a piece of wood inside the handle so as to get a better grip. The metal liner is expendable but should be turned in for salvage.

Ammunition boxes should not be opened nor the metal liner broken until the ammunition is required for issue or use. Ammunition removed from the airtight container, particularly in damp climates may corrode, thereby causing the ammunition to become unserviceable.

*Handling cartridges.* After a box of ammunition has been opened and the cartridges removed, the primer should be protected from blows by sharp instruments as such a blow might explode the cartridges.

Ammunition should be protected from mud, sand, dirt, and water. If it gets wet or dirty, it should be wiped off at once. Verdigris or light corrosion should be wiped off. However, cartridges should not be polished to make them look better or brighter. The use of abrasives is forbidden. If a cartridge case becomes so corroded that a perceptible amount of metal is eaten away, it is dangerous to fire and should not be used.

The use of oil on cartridge cases is prohibited. Greasing or oiling cartridges used in machine guns and automatic arms cause the collection of dust and other abrasives which are injurious. Grease or oil on cartridge cases or on the walls of the chamber in nonautomatic rifles creates excessive and hazardous pressure on the rifle bolt. When there is oil on the cartridge case, there is no adhesion of the case to the chamber. When the case expands upon firing, the case slips back, and the bolt receives a greater rearward thrust. An apparent exception exists in the case of lead bullets. However, only the bullet is waxed or greased as issued.

Ammunition should not be exposed to the direct rays of the sun for any length of time. If the powder is heated, it is likely to cause excessive pressure when fired and will affect the performance of the ammunition.

Whenever cartridges are taken from cartons and loaded into belts or clips, the latter should be tagged or otherwise marked so that the ammunition may be identified as to lot number and manufacturer. Such identification is necessary to prevent otherwise serviceable ammunition from being placed in grade 3, because of loss of lot number.

*Defective cartridges.* Dented cartridges, cartridges with loose bullets, or otherwise defective rounds should not be issued. Lots having more than 5 percent of defective cartridges will be subjected to 100 percent inspection. Defective rounds will be culled out, the

**SMALL ARMS AND TRENCH WARFARE**

serviceable rounds repacked, and a report made to the Chief of Ordnance. If 20 percent or more are defective, the lot is withdrawn from issue and held for disposition. Particular attention should be paid to incipient cracks which are not easily detected unless the thumb is pressed against the bullet, thus exposing the crack in the cartridge case. Defective cartridges will be considered as grade 3 ammunition.

No small-arms ammunition may be issued until it has been positively identified by ammunition lot number and grade, as published in the latest revision of OFSB 3-5.

**Storage.**

**Piling by lot.** Small-arms ammunition should be stored and piled according to type and ammunition lot number. Extreme care must be exercised to prevent the mixing of ammunition lots in one pile. When small-arms ammunition is received, issued, checked, stacked, or restacked, reliable personnel should be in charge and a check made of the ammunition lot number on each box.

**Grade 3 ammunition.** Whenever grade 3 ammunition is to be stored it should, if possible, be segregated and plainly marked with some sort of "issues prohibited" tags.

**Protection.** Whenever practicable, small-arms ammunition should be stored under cover. This applies particularly to tracer and shotgun ammunition. Tracer ammunition is subject to rapid deterioration if it becomes damp, and may even ignite spontaneously. Shotgun shells are not packed in waterproof metal-lined boxes except for overseas shipment.

Although small-arms ammunition is packed in boxes with metal liners, actual tests have shown that leaks in liners are developed in handling and shipping to the extent of 8 percent in newly packed ammunition, while in the older lots leaks have been found in as high as 70 percent of the liners. The leaks, though small, will admit moisture if the ammunition is exposed to the weather or extreme variations in temperature.

Should it become necessary to leave small-arms ammunition in the open, it should be raised on dunnage at least 6 inches from the ground and the pile should be covered with a double thickness of serviceable tarpaulin. Care must be exercised in using a tarpaulin to give the pile sufficient ventilation and to avoid the building-up of extreme temperature, especially in warm weather. Suitable trenches should be dug to prevent water flowing under the pile.

**Tracer ammunition storage.** If practicable, tracer ammunition should be stored separately from other ammunition.

**High temperatures.** Small-arms ammunition in storage should be protected from extreme heat to avoid decomposition of the propellant

## AMMUNITION INSPECTION GUIDE

powder. The combination of high temperature and a damp atmosphere is particularly detrimental to the powder.

*Opened boxes.* When only a part of a box is used, the remaining ammunition should be protected against unauthorized handling and use by fastening the cover firmly in place. Such boxes should also be marked with a "light box" tag and be placed in a conspicuous place.

*Fire hazard.* If placed in a fire, small-arms ammunition does not explode violently. There are small individual explosions of each cartridge, the case flying in one direction and the bullet in another. In case of fire, it is advisable to keep personnel not engaged in fighting the fire at least 200 yards distant, and have them lie on the ground. It is unlikely that bullets and cases will fly over 200 yards.

**FURTHER REFERENCES:** OS 9-18, Vol. I, Ammunition General (Small Arms); O.O. 7224, Ordnance Safety Manual; TM 9-1990, Small-arms Ammunition; OFSB 3-5, Grades and Lot Numbers; SNL's, T-series TB 1990-1, Marking of Cartridge Packing Boxes.

---

---

## Chapter 2

### 20-mm Ammunition

#### GENERAL.

The use of 20-mm ammunition against aircraft has been very significant in World War II. The Mk. II and Mk. IV Guns, commonly referred to as "Oerlikon guns," used for antiaircraft firing by the Navy have given outstanding performance and may be adopted by the Army. The present use of 20-mm ammunition by the Army is in Guns M1 and M2 which are mounted in aircraft. M1 and M2 Gun ammunition is also fired in the British Hispano gun mounted in aircraft. All 20-mm ammunition is of the fixed class, the cartridge case containing the propellant and primer is crimped rigidly to the projectile. The complete round is loaded into the weapon as a unit.

**Weapons.** The 20-mm M1, AN-M2, and Hispano guns are mounted for firing through the propeller hubs, or from fixed mounts in the wings of aircraft. They are capable of delivering fire at the rate of 600-700 rounds per minute. The guns are fed from either a 60-round drum-type magazine, or from disintegrating link belts similar to those used for machine gun ammunition.

**Types of Ammunition.** Types of ammunition authorized for use in the M1, AN-M2, and Hispano guns are:

H.E.-I (High-explosive-incendiary)

Ball AP-T (armor-piercing with tracer)

All types are standard for issue and manufacture.

#### CARTRIDGE, H.E.-I, MK. I.

**Complete Round.** The CARTRIDGE, H.E.-I, Mk. I, w/FUZE, percussion, D.A., No. 253 Mk. I /A/, was adopted from the British in 1941. Little modification has followed except in the redesign of the cartridge case and primer. The fuzed projectile remains the same as may be sensed from the adopted British nomenclature. (/A/ is the British symbol for shell used in aircraft mounted guns.) The



AMMUNITION INSPECTION GUIDE

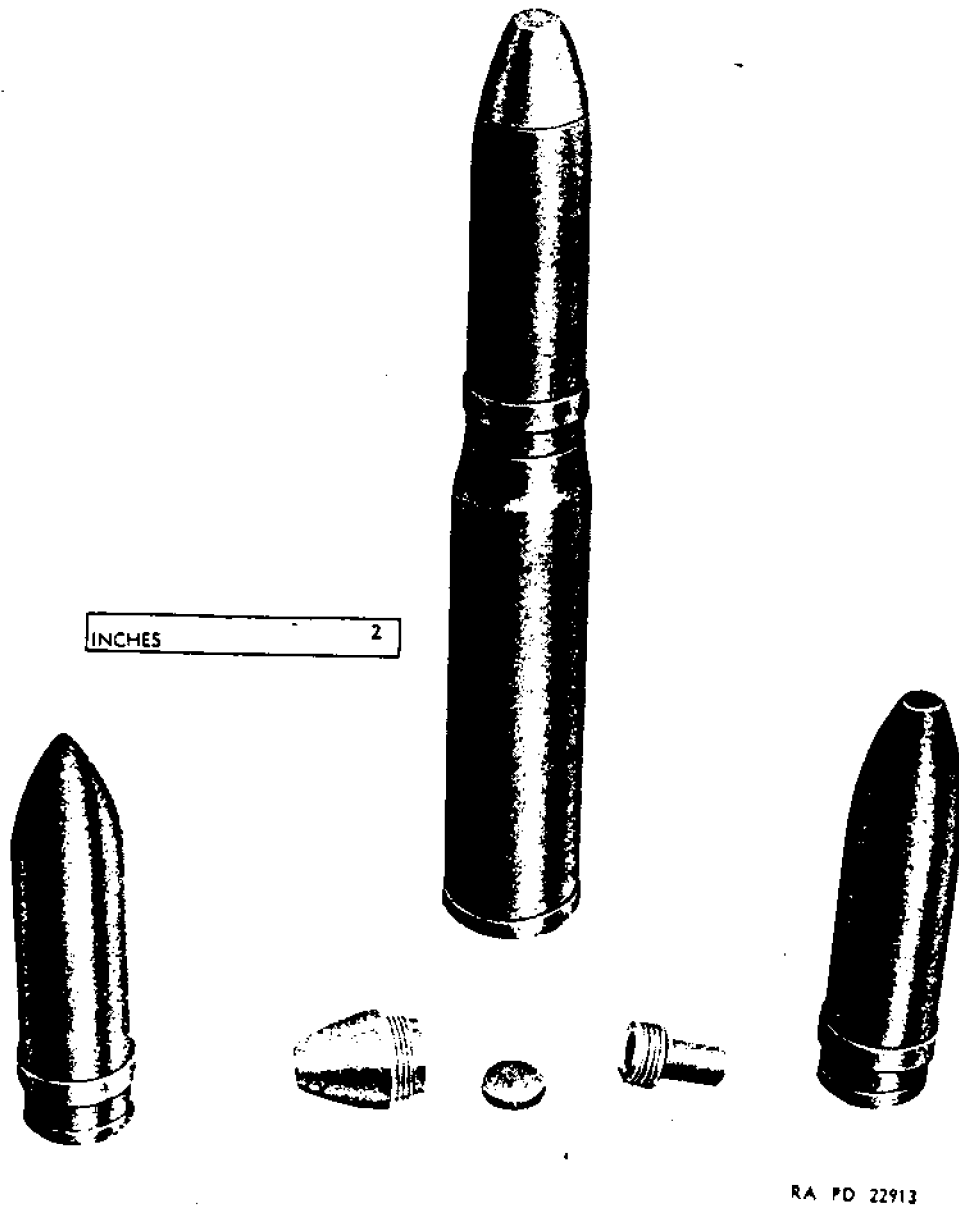

*Figure 124 — Ammunition for 20-mm Guns M1, AN-M2, and British Hispano/A/ (Aircraft)*

324

## ARTILLERY AMMUNITION

tridge is fired from aircraft guns against aircraft, primarily, although it may be directed against light ground targets and personnel. The complete round consists of the cartridge case, primer, propellant, and the projectile with its fuze and high-explosive-incendiary charge. It is 7.19 inches long, and weighs 0.57 pound.

**Cartridge Cases.** There are three cases used with this round:

*Cartridge case M21A1.* This is the standard cartridge case. It is made of cartridge brass and is very similar in appearance to cal. .50 small-arms cases.

*Cartridge case M21A1B1.* This case is "Substitute Standard." It is identical to the M21A1 except that it is made of steel and has a deeper extracting groove machined in the head. The "B1" designation on cartridge cases refers to steel as a substitute for cartridge brass.

*Cartridge case M21.* This case is "Limited Standard" and its manufacture has ceased. It differs from the M21A1 Case in that its primer recess is machined to receive the M37 (Berdan) Primer. In this type of primer, the anvil is not a component of the primer, but is a part of the cartridge case. The case also has two flash vents instead of the single vent found in the M21A1.

**Primers.** The PRIMER, percussion, M36, is standard for assembly in Cartridge Cases M21A1 and M21A1B1. It is the American type of primer with the anvil included. The primer consists of a brass primer cup, a strip brass anvil, a foiling paper cover, and a primer mixture of 2.1 grains. The primer is press fit into the cartridge case and is either staked with five equally spaced stab crimps, or is roll crimped in place.

The PRIMER, Berdan type, M37, is used with the M21 Cartridge Case. It differs from the American type primer in that it has no anvil. (The anvil is machined from the cartridge case.)

**Propelling Charge.** The standard propellant for the H.E.-I round is FNH (flashless and nonhygroscopic) powder, type II. Approximately 0.07 pound is poured loosely into the cartridge case.

**Projectile.** The projectile is made of cold-drawn steel and two recesses are machined into the body; one to receive a copper or gilding metal rotating band, the other is the cannellure into which the cartridge case is crimped. The cartridge case is crimped to the projectile with a minimum of four stab crimps or a continuous crimp. The thickness of the body at the base is only 0.15 inch, and to prevent a premature explosion a base cover is added. This cover is secured by a continuous resistance weld entirely around the edge. If the base cover were not used, there is a possibility that the propelling charge would initiate the explosive filler through flaws or cracks

# AMMUNITION INSPECTION GUIDE

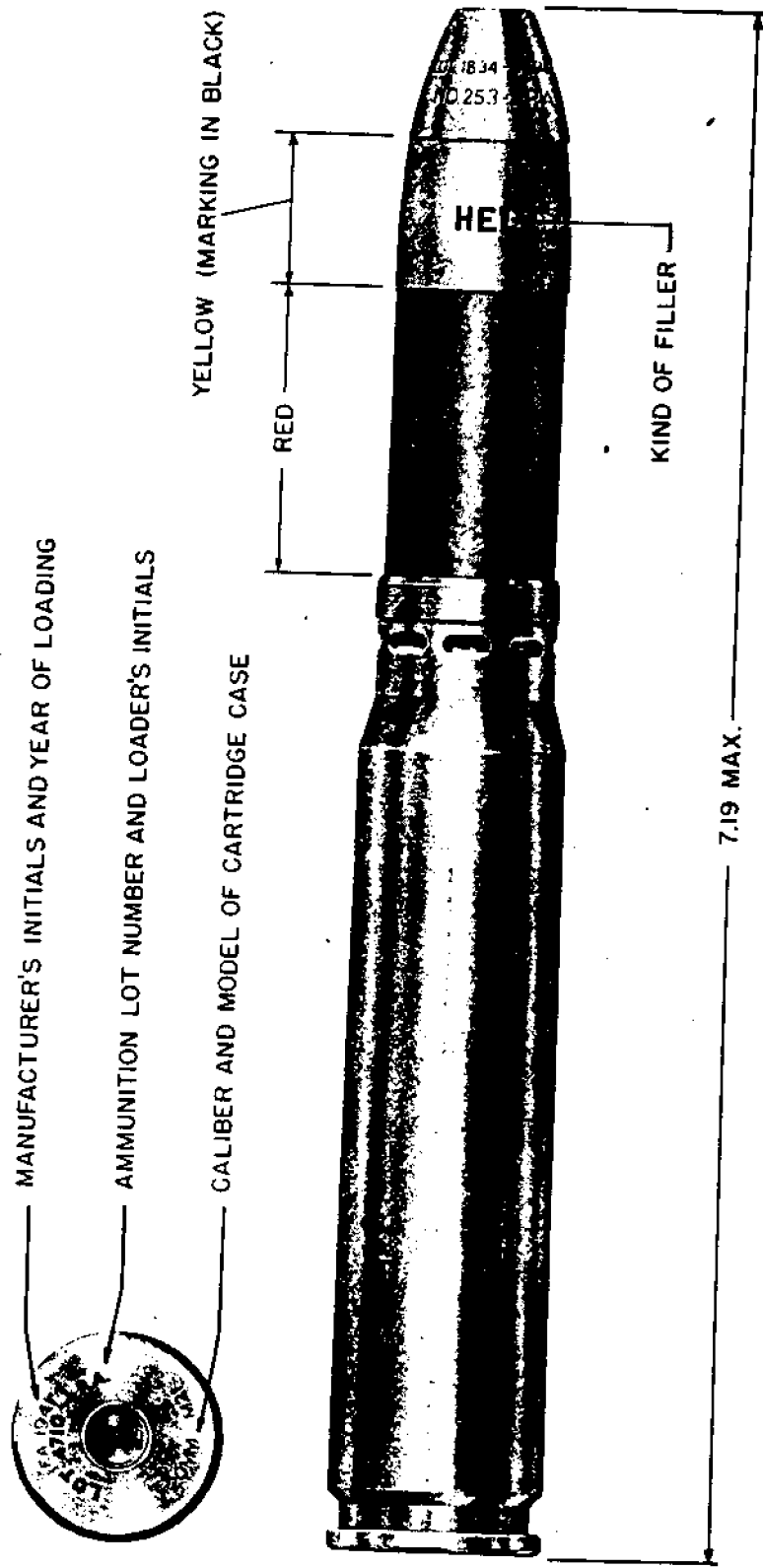

RA PD 4500

**Figure 125 — 20-mm Cartridge, H.E.-I, Mk. I**

ARTILLERY AMMUNITION

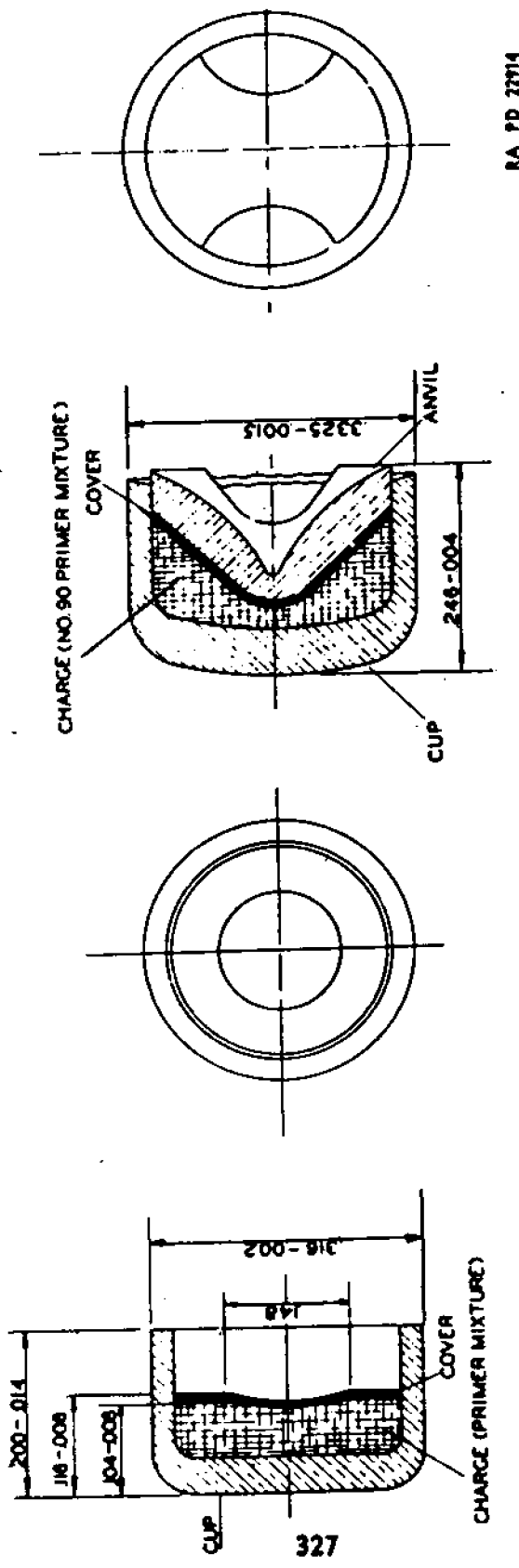

PRIMER, M36  
STANDARD

PRIMER, M37  
LIMITED STANDARD

Figure 126 — 20-mm Primers

**AMMUNITION INSPECTION GUIDE**

in the base of the shell. The projectile has a radius of ogive of 2.56 inches.

The filler for the projectile is high-explosive incendiary in nature, and weighs 175.2 grains. Details on the filler are classed as confidential at this time.

**Fuze.** The FUZE, percussion, D.A., No. 253 Mk. I /A/, is made of brass, and is streamlined to continue the ogive of the projectile. It is designed to function after the projectile has entered the plane, but before it penetrates the opposite wall. The projectile will thus burst inside of the cockpit of the plane, for example, where the fragments and incendiary bursting charge will be most effective. The fuze is not boresafe since there is no positive separation between the detonator and the booster. It is threaded into the projectile and secured with either three equally-spaced stab crimps or Pettman cement. Further details of the construction and function of the fuze are not available for publication at this time.

**Identification.** From the rearmost portion of the bourrelet forward, the surface of the projectile is painted yellow, with the letters "HEI," indicating the type of filler, stencilled in black. The remainder of the projectile, as far as the rotating band, is painted red.

**CARTRIDGE, AP-T, M75.**

**Complete Round.** This cartridge is used primarily from aircraft against the armored parts of other aircraft, and may also be used against lightly armored ground and sea-borne targets. The complete round is 7.22 inches long, and weighs 0.639 pound.

**Cartridge Cases and Primers.** M21A1, "Standard," M21A1B1, "Substitute Standard," or M21, "Limited Standard" cartridge cases with the appropriate primers may be used with this round (cartridge cases, page 325, and primers, page 325).

**Propelling Charge.** 0.066 pound of FNH powder, type II is poured loosely into the cartridge case.

**Projectile.** The projectile is machined from cold-drawn bar steel. A recess for seating the rotating band and a cannellure to receive the cartridge case crimps are cut into the projectile. The radius of ogive is 1.875 inches except for the very tip which is rounded giving it a blunted appearance. There is a cavity machined into the base to receive a tracer.

**Tracer.** The "T" in the nomenclature of this round stands for tracer mixture which is charged into the cavity in the base of the projectile. After the tracer charge is loaded, it is sealed by the assembly of a celluloid closing cup held in place by an adhesive compound.

ARTILLERY AMMUNITION

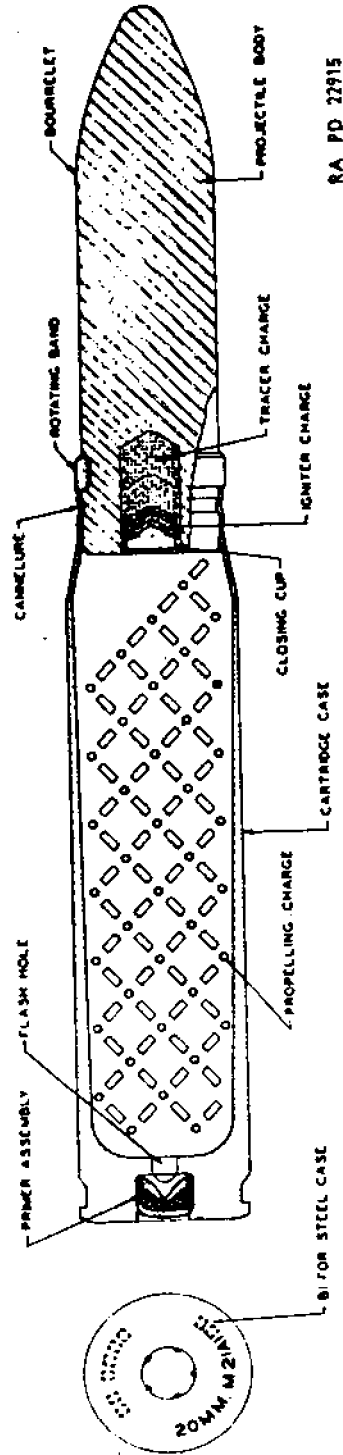

Figure 127 — 20-mm Cartridge, AP-T, M75

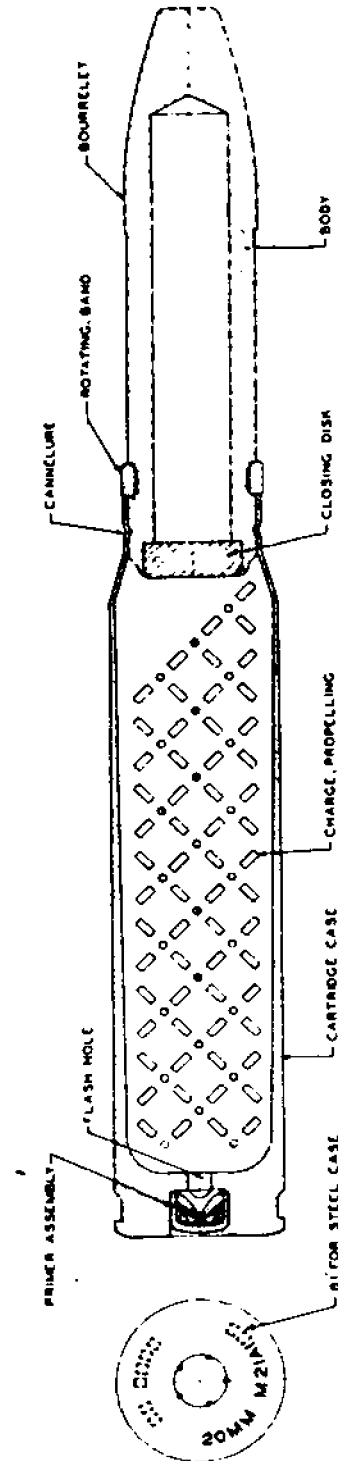

Figure 128 — 20-mm Cartridge, Ball

## AMMUNITION INSPECTION GUIDE

The heat from the propellant ignites the closing disc which in turn starts the tracer mixture burning.

The purpose of the tracer is to make a portion of the flight of the projectile visible so that the gunner may correct the line of fire and find the target.

**Identification.** The projectile is solid except for the tracer cavity, and the nose is slightly rounded. It is painted with black lacquer enamel excepting the rotating band which must remain clean.

### CARTRIDGE, BALL.

**Complete Round.** The CARTRIDGE, ball, was designed to simulate the H.E.-I Mk. I for practice firing purposes. Since the projectile is cheap and easy to manufacture, its use for practice firing is economical. As indicated by the nomenclature, the round has lately been adopted for actual combat fire. The ballistics and effectiveness of the round in the field have warranted its manufacture and issue for combat. The complete round is 7.23 inches long and weighs 0.56 pound.

**Cartridge Cases and Primers.** M21A1, M21A1B1, or M21 Cartridge Cases with appropriate primers, are used (cartridge cases, page 325, and primers, page 325).

**Propelling Charge.** 0.07 pound of FNH powder is held loosely in the cartridge case.

**Projectile.** The projectile is machined from bar steel with a recess for a copper rotating band and a cannelure for securing the cartridge case. A cavity extending from the rear to about seven-eighths the length of the projectile brings it to the desired weight. A steel closing disc is fitted into the base. The nose of the projectile has an ogive radius of 2.56 inches. The nose appears to have been cut off squarely about  $\frac{1}{4}$  inch from the tip. No tracer is incorporated.

**Identification.** The entire projectile except for the rotating band is painted black. The cut-off nose and the lack of any identifying marking on the projectile body serves to differentiate between the ball and the AP round.

### PACKING.

The three complete rounds for the 20-mm Automatic Guns, M1, AN-M2, and British Hispano /A/, are packed similarly. Ten rounds are packed in a heavy chipboard carton. The carton is in two parts, the cartridges are placed nose down in two vertical rows of five in the bottom part, and covered with the upper part, which is labeled and glued in place. Twelve of these cartons, making a total of 120 rounds, are placed in a metal-lined wooden box.

Detailed packing data may be obtained from ordnance drawings. The numbers of these drawings may be found under packing data for 20-mm ammunition in SNL R-1, Part 2.

**FURTHER REFERENCES:** OS 9-20, Vol. II; SNL R-1; Ordnance Drawings; Complete Round Chart No. 5981.

---



---

## Chapter 2

### Hand Grenades

#### GENERAL.

Hand grenades form an important class of ammunition, especially for trench warfare. They are a convenient type of ammunition which, within certain limitations, enables the infantry to augment its primary weapons with a missile somewhat similar in action to a shell or bomb. Chemical hand grenades that produce clouds of irritant gases are also effective in dispersing mobs, quelling riots, etc.

**Types.** Hand grenades are divided into three general types, namely: explosive grenades containing a heavy charge of explosive, chemical grenades which contain a chemical filler, and training grenades developed for training in the use of grenades. At the present time, the Chemical Warfare Service handles all chemical hand grenades and there will be no discussion of this type.

#### GRENAD, HAND, FRAGMENTATION, MK. II, WITH HAND GRENAD, IGNITING FUZE M10A2.

**General.** The Fragmentation Hand Grenade Mk. II, loaded with E. C. Blank smokeless powder and assembled with the Hand Grenade Igniting Fuze M10A2 is the standard for manufacture and issue. Its function is to cause casualties due to fragments of the grenade body. The grenade complete weighs approximately 20 ounces. This grenade, as issued, is shown in figure 90.

## SMALL ARMS AND TRENCH WARFARE

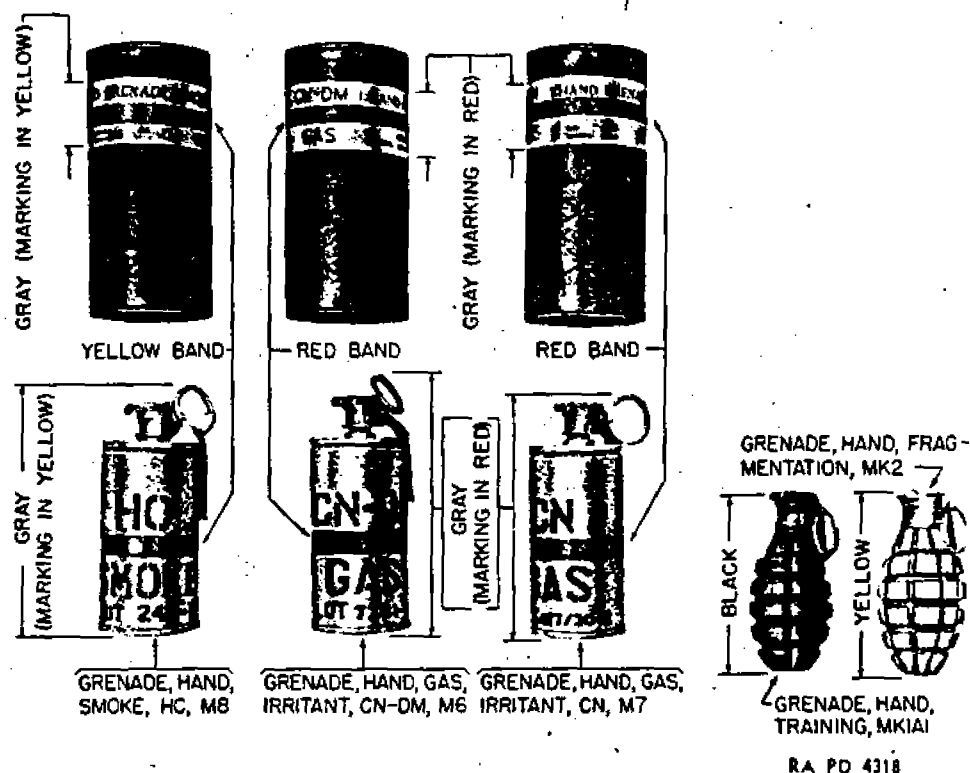

Figure 89 — Hand Grenades

**Body.** The Fragmentation Hand Grenade Body Mk. II, is made of cast iron. It is about the size and shape of a large lemon and is designed to fit comfortably in the hand. The outside surface is deeply serrated, horizontally and vertically, to assist in forming uniform fragments of effective size when the grenade explodes. The opening in the top is threaded for assembly of the fuze. The body weighs approximately 1 pound, empty.

**Bursting Charge.** The explosive filler or bursting charge consists of 0.74 ounce of E. C. Blank smokeless powder. This is a commercial type of semicolloided nitrocellulose, granulated into small shot-like grains. It is generally pink or yellow in color and is associated with the words "blank fire" in that its principal use has been for loading blank ammunition for small arms.

**FUZE, Igniting, Hand Grenade, M10.** This is a mechanical device assembled to the grenade body which functions the grenade at the time and under the circumstances desired. (For details, see figure 90.) The fuze body (16, fig. 90) is threaded and screwed into the opening in the top of the grenade body. A lever (10, fig. 90) covers the top of the fuze body, one end being bent over to hook under a protruding lip. The other end of lever extends downward and is curved to follow the contour of the grenade body. A cotter pin (11, fig. 90) with a ring (20, fig. 90) in the eye extends through

## AMMUNITION INSPECTION GUIDE

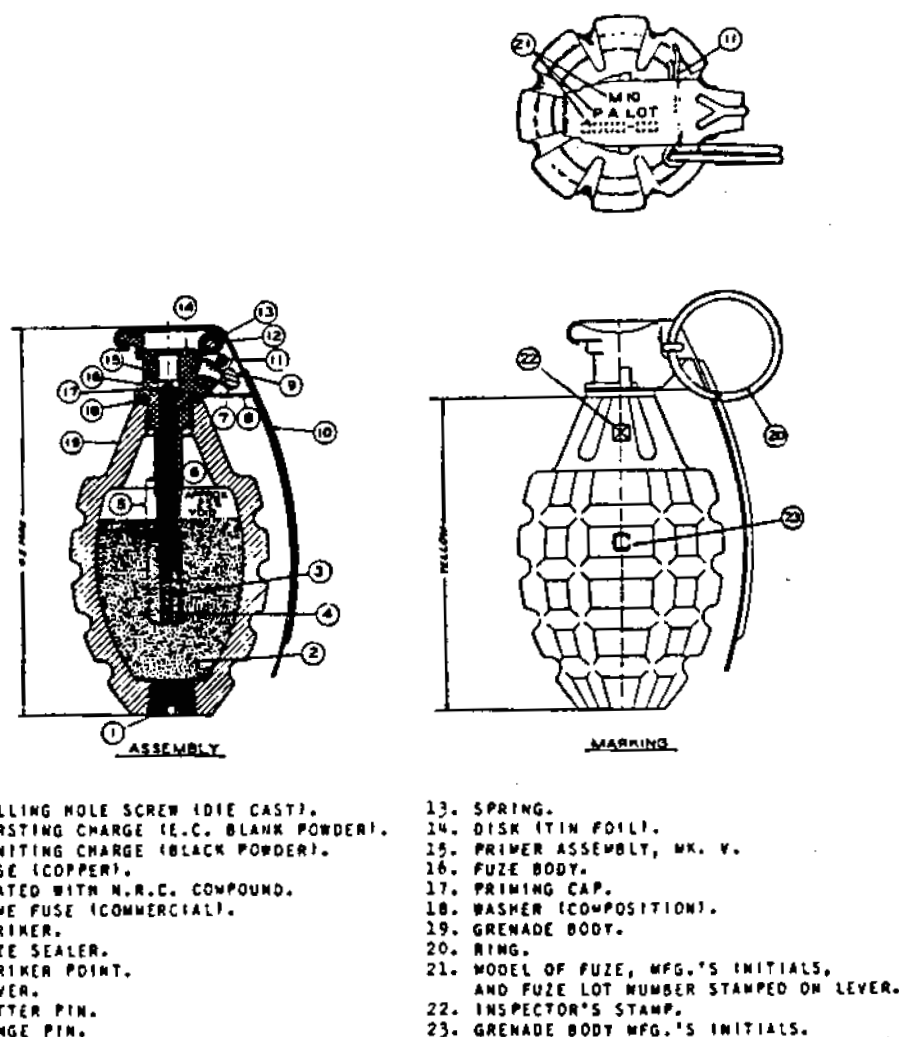

- |  |   |
|--|---|
| <ol style="list-style-type: none"> <li>1. FILLING HOLE SCREW (DIE CAST).</li> <li>2. BURSTING CHARGE (E.C. BLANK POWDER).</li> <li>3. IGNITING CHARGE (BLACK POWDER).</li> <li>4. CASE (COPPER).</li> <li>5. COATED WITH N.R.C. COMPOUND.</li> <li>6. TIME FUSE (COMMERCIAL).</li> <li>7. STRIKER.</li> <li>8. FUZE SEALER.</li> <li>9. STRIKER POINT.</li> <li>10. LEVER.</li> <li>11. COTTER PIN.</li> <li>12. HINGE PIN.</li> </ol> | <ol style="list-style-type: none"> <li>13. SPRING.</li> <li>14. DISK (TIN FOIL).</li> <li>15. PRIMER ASSEMBLY, MK. V.</li> <li>16. FUZE BODY.</li> <li>17. PRIMING CAP.</li> <li>18. WASHER (COMPOSITION).</li> <li>19. GRENADE BODY.</li> <li>20. RING.</li> <li>21. MODEL OF FUZE, MFG.'S INITIALS, AND FUZE LOT NUMBER STAMPED ON LEVER.</li> <li>22. INSPECTOR'S STAMP.</li> <li>23. GRENADE BODY MFG.'S INITIALS.</li> </ol> |
|--|---|

ORD 9417

**Figure 90 — GRENADE, Hand, Fragmentation, Mk. II, w Hand Grenade Igniting Fuze M10**

holes in the lever and fuze body, holding the lever and striker assembly (7, fig. 90) in place against the action of the spring (13, fig. 90). The primer (15, fig. 90) is of the center fire type and is known as the Mk. V. It contains a 0.4-grain charge of primer mixture in a cup inverted over an anvil. When the cotter pin (11, fig. 90) is removed and the lever (10, fig. 90) released, pressure from the spring (13, fig. 90) rotates the striker (7, fig. 90) around the hinge pin (12, fig. 90). The point of the striker impacts against the primer cup and explodes the primer charge by crushing it on the anvil. The flame from the primer charge flashes through the primer body and ignites a 2-inch piece of commercial time fuse (6, fig. 90). This burns for approximately 5 seconds while conducting the flame to the igniting charge (3, fig. 90) which then explodes and functions the grenade.

SMALL ARMS AND TRENCH WARFARE

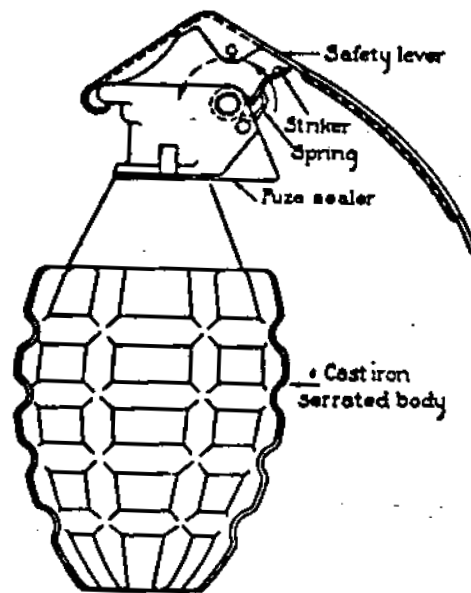

RA PD 15194

Figure 91 — GRENADE, Hand, Fragmentation, Mk. II

The igniting charge consists of 7 grains of loose black powder contained in a copper case (4, fig. 90). The open end of the case extends inside the stem of the fuze body and is crimped in place, the joint being waterproofed by an application of green colored N.R.C. compound. The primer end of the fuze is protected against the entrance of moisture by a tin foil disc (14, fig. 90) which is sealed in place with shellac varnish. Other components of the fuze are the fuze sealer

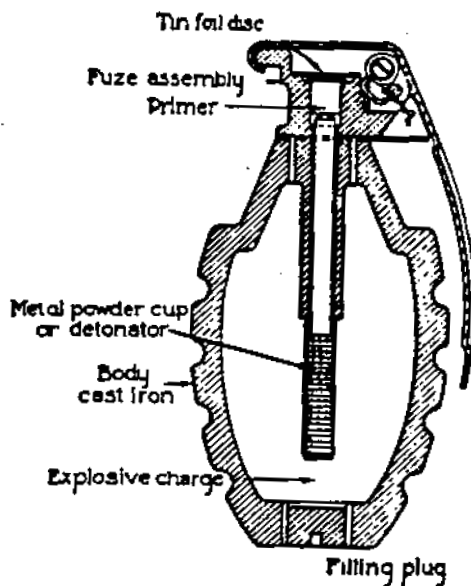

RA PD 15195

Figure 92 — Grenade — Section View

## AMMUNITION INSPECTION GUIDE

(8, fig. 90) and the composition washer (18, fig. 90). The fuze sealer is a piece of sheet metal which fits around the fuze body just above the threaded portion. Two projecting sides fit the triangular space between the fuze body and lever, thus preventing the entrance of mud, sand, or other foreign material into the firing mechanism. The composition washer serves as a gasket between the fuze and grenade body when the fuze is seated in place. Should the spring (13, fig. 90) lose its strength or become "set," failure of the fuze will result. It has been found necessary to replace old springs with new ones after long periods of storage. The complete fuze weighs approximately 3.22 ounces.

**FUZE, Igniting, Hand Grenade, M10A1.** The A1 modification of the FUZE, igniting, hand grenade, M10, consists of a redesign of the head of the fuze so that the fuze sealer washer is dispensed with and yet the striking mechanism is completely enclosed as before.

**FUZE, Igniting, Hand Grenade, M10A2.** The A2 modification of the FUZE, igniting, hand grenade, M10, consists of a change in the explosive train. The length of the Bickford fuse is shortened from 2 inches to  $1\frac{5}{16}$  inches, and between it and the primer are two delay pellets of compressed black powder. The delay time remains 5 seconds, 2 seconds being obtained from the black powder pellet and 3 seconds from the shortened length of Bickford fuse. This modification was found necessary in order to prevent the primer flame from completely bypassing the Bickford fuse and igniting the igniting charge directly when small diameters of Bickford fuse were coincidentally associated with large inner diameters of the fuze stem.

**Operation:** The grenade is grasped in the throwing hand with the lever held firmly against the grenade body. The first finger of the free hand is inserted in the ring, gripping it firmly between the second and third joints of the finger. The cotter pin is withdrawn by pulling the ring. The grenade is then ready to be thrown. The thrower must take every precaution after the cotter pin has been withdrawn, not to release his grip on the lever until the grenade is thrown. The grenade is thrown with a full swing of the cocked arm as one would throw a ball. The instant the grenade is released, the striker forces the lever away and fires the primer as shown in figure 91. Five seconds later the action of the fuze causes the grenade to explode. The body bursts, forming many small fragments, some of which may fly over 200 yards. Personnel should be thoroughly familiar with the safety precautions in the following paragraphs before attempting to fire live fragmentation hand grenades.

### Safety Precautions.

1. A live fragmentation hand grenade should never be thrown un-

## SMALL ARMS AND TRENCH WARFARE

less cover is at hand behind which the operator and friendly troops may secure shelter. Fragments may fly over 200 yards.

2. The grenade should not be armed by withdrawing the cotter pin unless the grenade is to be thrown at once. If the lever is accidentally released after the cotter pin is withdrawn, the striker will function immediately and the grenade will explode in approximately 5 seconds.

3. If the striker is accidentally allowed to function, the grenade should be thrown as far as possible and the thrower should seek shelter, but if none is near he should drop flat on the ground and lie prone.

4. If the grenade is accidentally dropped after the cotter pin has been removed, it should be picked up and thrown immediately; there is plenty of time if one does not hesitate. It will function in 4 or 5 seconds, but it can be thrown farther than one can run in that length of time. The operator should throw himself flat on the ground, as above, and warn others near him to do likewise.

5. It should never be assumed that one can guess when 5 seconds have elapsed, and allow the striker to function a moment or so before throwing the grenade. The material on the A2 modification of the fuze should bear out the wisdom of this precaution.

6. Live grenades that fail to fire (duds) should be handled very carefully in the manner prescribed in FM 23-30.

7. It should be kept in mind that the hand grenade is always loaded and cocked. It is always pointed at you. It is safe and effective when properly handled, but it is very dangerous when handled otherwise.

**Painting and Marking.** Loaded Fragmentation Hand Grenades Mk. II, are painted lustreless olive drab. The levers of the igniting fuzes are stamped with the fuze model, lot number of loaded fuze, and the fuze loader's initials.

**Packing.** Loaded and fuzed fragmentation hand grenades are packed in individual fiber containers, 25 grenades in containers per wooden packing box.

### GRENADe, HAND, OFFENSIVE, MK. IIIA1, UNFUZED (ADAPTED FOR HAND GRENADe DETONATING FUZE, M6A2).

**General.** Because of its structure, which is such that there is no marked fragmentation, this grenade can be used more safely in the open than can fragmentation hand grenades. It is used for demolition.

**Body.** The body of this grenade is formed of laminated cartridge paper and is fitted with light sheet metal plates crimped to the ends of the body. In the center of the top, a threaded brass collar

**AMMUNITION INSPECTION GUIDE**

crimped in place as an adapter for the FUZE, detonating, hand grenade, M6A2. The grenade is cylindrical in shape.

**Filler.** The filler of this grenade is a pressed charge of flake TNT.

**FUZE, Detonating, Hand Grenade, M6A2.** This fuze is similar in mechanical action to the FUZE, igniting, hand grenade, M10A2. It is provided with a 5-second delay.

**Painting and Marking.** The loaded grenade body is black in color. A yellow gummed paper sealer runs about the center of the body and is printed with the type, the model, the lot number, the date of loading, and the loader's initials.

**Packing.** The loaded offensive hand grenade and the FUZE, detonating, hand grenade, M6A2, are packed and shipped separately. The loaded grenade bodies are packed 24 per box or 50 per box. The fuzes are packed 25 per carton, 8 cartons (200 fuzes) and 1 wrench (for field assembly of fuze to grenade) per box.

**GRENADE, HAND, TRAINING, MK. IA1.**

**General.** The training hand grenade is made of cast iron and is approximately the same shape, size, and weight as a loaded Fragmentation Hand Grenade Mk. II. A projection is cast on the top and side to represent the fuze assembly. The A1 modification consists of the addition of a cotter pin and pull ring to a hole drilled in appropriate position through this projection. This more closely simulates the operations involved in the throwing of a fragmentation hand grenade. The training hand grenade is used for preliminary practice in grenade throwing.

**Painting and Marking.** This grenade is painted black; that being its only distinctive marking.

**Packing.** This grenade is packed 24 per box.

**FURTHER REFERENCES:** SNL S-4; OFSB 3-10; TM 9-1900, TM 9-1985; FM 23-30; O.O. 7224.

---

## Chapter 4

### Rifle Grenades and Rockets

#### RIFLE GRENADES.

**General.** Rifle grenades fall into three general types: antitank grenades, practice antitank grenades, and fragmentation grenades. These types are designed to be fired from the cal. .30 rifle and the



**AMMUNITION INSPECTION GUIDE**

cal. .30 carbine. The various weapons used to project the rifle grenades require certain accessories.

The U. S. RIFLE, cal. .30, M1903, requires a launcher which is attached to the muzzle of the rifle, and the CARTRIDGE, rifle grenade, cal. .30, M3.

The U. S. RIFLE, cal. .30, M1903A1 and M1917, may also be used to project rifle grenades. In such cases, each of the above rifles requires a special sight and the M1917 Rifle also requires a special launcher, designed to fit this weapon in particular.

The cal. .30 carbine requires a special launcher and the CARTRIDGE, grenade, carbine, cal. .30, M6. No further information is available at the present time with regard to these accessories for the firing of rifle grenades from the carbine.

The original issue of antitank grenades to an individual soldier is made by means of a kit which contains, in addition to a supply of grenades and cartridge, the necessary auxiliary equipment for the rifle with which he is provided. Subsequent issues consist of only rifle grenades and cartridges until such time as replacement of the accessories becomes necessary.

**GRENADe, Rifle, H.E., M9.** This is the originally developed antitank grenade, and is now standard for issue only since an improved type has been developed. It has a sheet metal body and weighs 1.5 pounds. It will detonate upon impact, provided the surface struck and the angle of impact are such as to exert pressure on the projection on the nose of the grenade (fig. 99).

**GRENADe, AT, M9A1.** This grenade also has a sheet metal body, but weighs only 1.31 pounds. It is more sensitive than the M9 and may detonate upon impact with soft earth. However, for certainty of detonation, it should strike the target head-on, or nearly so. The grenade consists of two principal parts: the high explosive head, and the stabilizer tube and fin assembly (fig. 99). The head of the grenade is composed of the ogive, or forward rounded portion; and the body, or rear portion to which the ogive is crimped. The charge of the grenade is 50/50 cast pentolite with the exception of a 10/90 cast pentolite booster surround.

This type of charge is known by the name "shaped charged." The effect of such a shaped charge on armor plate is very unusual. It appears to focus the detonating wave against a small area of the plate. This focused and concentrated wave hits the plate with such terrific force that a roughly cylindrical hole is driven through it. The metal of the plate is raised to an incandescent heat and issues from the rear of the hole in the armor in the form of a cone-shaped spray whose angle of opening is approximately 90 degrees. This effect of the shaped charge is also known as the "Munroe effect," receiving this

SMALL ARMS AND TRENCH WARFARE

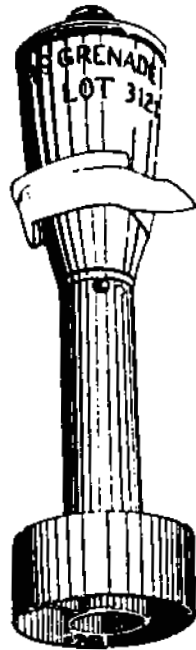

GRENADE, AT, M9.



CARTRIDGE,  
AT, GRENADE, M3



GRENADE, AT, M9A1.

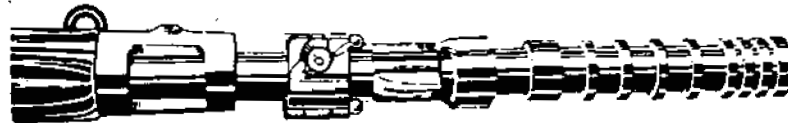

LAUNCHER, GRENADE, M1.

RA PD 15196

Figure 99 — Rifle Grenades and Launcher

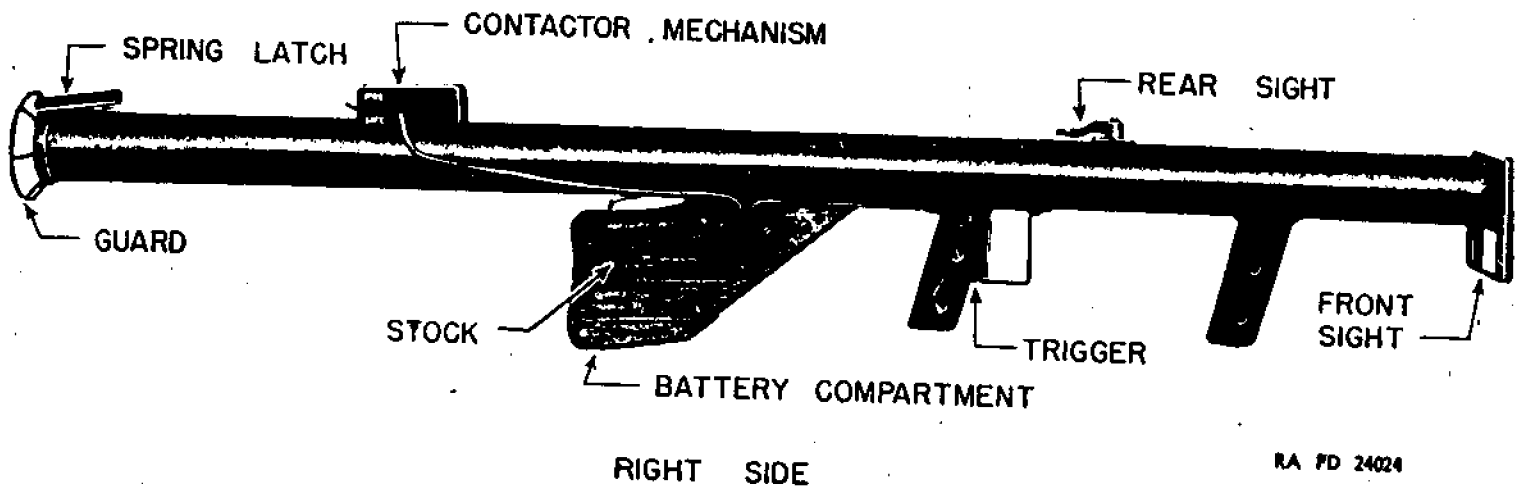
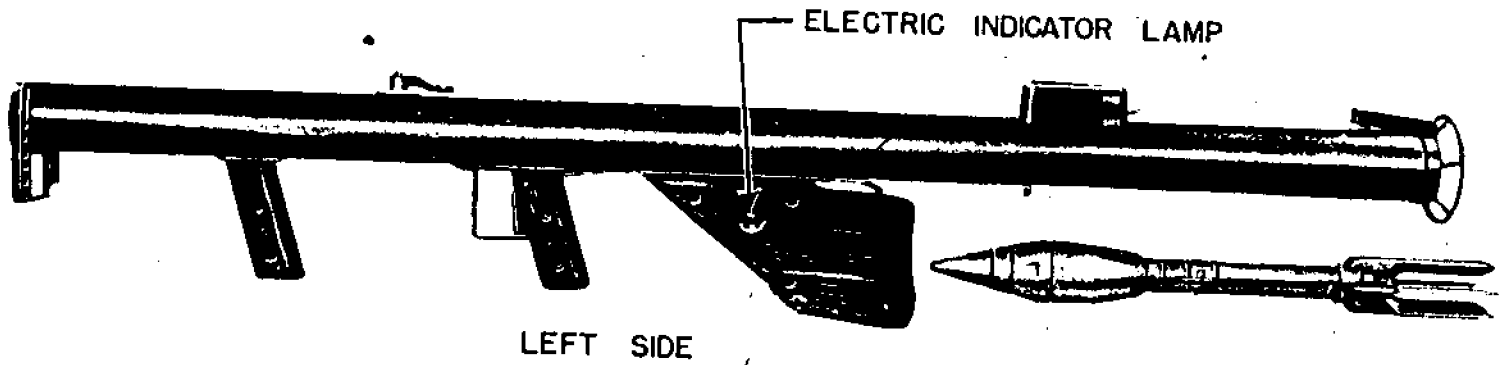

256

RA FD 24024

Figure 100 — Launcher, Rocket, AT, M1

## SMALL ARMS AND TRENCH WARFARE

name from that of the discoverer of the effect of shaping charges. Some figures substantiating the effect on armor plate will be presented in the sections dealing with antitank rockets.

The stabilizer assembly consists of these major parts: the fuze body, which contains the fuze parts and which threads into the union; the stabilizer tube, which attaches to the rear of the fuze body with four rivet-like pins; and the fin, which is spot-welded to the rear of the stabilizer tube.

The fuze is a simple impact firing device consisting of a spring restrained striker, which on impact strikes a detonator of priming mixture, lead azide, and tetryl, which in turn causes detonation of a booster of tetryl. The wave from the booster in turn detonates the bursting charge in the grenade body. The striker is held safe in storage by a safety pin which clips to the stabilizer tube and passes through the fuze body, at the same time engaging an annual groove in the striker. This safety pin must be removed prior to firing the grenade.

The stabilizer tube serves two purposes, an attachment for the fin, and a support for the grenade on the launcher. The tube is slipped over the end of the launcher. The fin, of course, stabilizes the flight of the grenade.

It should be noted that the penetration of the grenade is not achieved by its velocity, the initial velocity being in the vicinity of 150 feet per second, but entirely by the effect of the shaped charge.

**GRENADERS, AT, Practice, M11 and M11A1.** These grenades are dummy (inert) grenades, similar in size, shape, and weight to the **GRENADE, rifle, HE, M9**, and the **GRENADE, AT, M9A1**, respectively. Each of these grenades consists of two parts, a head and a fin assembly. When damaged by repeated use, the fin assembly may be replaced. These grenades are used for target practice only.

**CARTRIDGE, Rifle Grenade, Cal. .30, M3.** This cartridge, used in discharging rifle grenades, is a special type of blank cartridge, recognizable by the rose crimp at its mouth. Only this cartridge must be used for this purpose. Neither ordinary blank ammunition nor ball ammunition may be used.

**LAUNCHER, Grenade, M1.** The launcher, on which the grenade is placed for firing, is an extension to the barrel of the rifle. A clamp with a wing nut is provided for attaching the launcher securely to the muzzle of the rifle. When the launcher is attached, the rifle may be employed for firing ball ammunition; however, the bayonet cannot be fixed. The rings and grooves on the launcher (fig. 99) act as gas checks, slowing down the escape of the propellant gases from the rifle grenade cartridge.

**Recoil Pad.** A rubber recoil pad is provided for protecting the rifle stock when the rifle is fired with butt resting against a hard sur-

## AMMUNITION INSPECTION GUIDE

face. The pad also lessens the shock of recoil when the rifle is fired from the shoulder.

**Painting and Marking.** High explosive grenades are painted a lustreless olive drab and stenciled in yellow with the model and lot number. Practice grenades are painted black and stenciled in white with the model and lot numbers.

**Packing.** GRENADES, rifle, HE, M9, and AT, M9A1, are packed 1 per fiber container, 10 containers and 11 cartridges per box.

GRENADE, AT, practice, M11, is packed 1 grenade and 1 cartridge per fiber container, 50 containers per box.

GRENADE, AT, practice, M11A1, is packed 1 per fiber container, 50 containers per box.

CARTRIDGE, rifle grenade, cal. .30, M3, is packed 20 per carton, 100 cartons (2,000 rounds) per metal lined box.

### GRENADE, Rifle, Fragmentation, Impact, M17.

**General.** The M17 Impact Fragmentation Rifle Grenade is an antipersonnel grenade for use in conjunction with standard grenade launchers, grenade cartridges, and cal. .30 rifles. The grenade is fired in a manner similar to the firing of the Antitank Grenade M9A1, except for the range determination. An impact type of fuze fires the grenade upon impact. The maximum range when fired from a grenade launcher on the M1917 or M1903 Rifles is about 220 yards.

**Description.** The grenade consists of a serrated cast iron body to which is fitted a tail assembly made up of a stabilizer tube and a fin assembly. An impact fuze is located in the forward end of the stabilizer tube. The firing pin is held in the unarmed position by a safety pin, which fits in an annular groove around it, through a hole in the fuze body, and clamps about the stabilizer tube. The safety pin and fuze is identical to that of the Antitank Grenade M9A1.

**Function.** The grenade is fired from a grenade launcher fitted to a cal. .30 rifle by using a standard rifle grenade cartridge (CARTRIDGE, rifle, grenade, cal. 30, M3). The safety pin must be removed before the grenade is fired. Upon impact, the fuze functions and detonates the grenade, provided the surface struck and the angle of impact are such as to exert pressure on the forward end of the grenade.

**Packing and marking.** The grenades are painted lustreless olive drab. Ten grenades in individual fiber containers and a carton of 11 rifle grenade cartridges are packed in a wooden packing box. Also included in the box are 3 launcher positioning clips for use in range determination.

## ROCKETS.

ROCKETS, AT, 2.36-inch. The 2.36-inch AT rockets are launched from the LAUNCHER, rocket, AT, M1. The launcher is

## SMALL ARMS AND TRENCH WARFARE

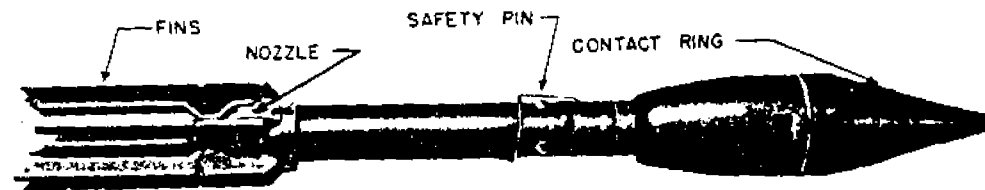

RA PD 24025

Figure 101 — ROCKET, AT, 2.36-inch, M6

an open tube approximately 54 inches long and 2.365 inches internal diameter, equipped with hand grips, stock, firing mechanism, and sights. The firing mechanism is electrical in nature, the ignition of the rocket propelling charge being accomplished by the current from a 2 dry-cell battery in the stock. The launcher may be fired from the shoulder. There is no recoil, since propulsion of the rocket is by jet action of the propelling gases. The range of the rockets ranges from 200 to 300 yards as an optimum, although longer ranges can be obtained. The muzzle velocity is about 300 feet per second. Two types of rocket are provided; namely, high-explosive and practice.

**ROCKET, AT, 2.36-inch, M6** (fig. 101). This rocket is a high-explosive projectile for use against tanks. It is 21½ inches long and weighs 3½ pounds. The rocket consists of three principal parts: the high-explosive head, the stabilizer tube, and the fin assembly.

The head consists of metal parts which are similar in function to the parts of the AT grenade head. These parts are the ogive and the body. The bursting charge is similar, both in that it is a "hollow" or a "shaped charge," and also in its composition which is mainly 50/50 pentolite with a 10/90 pentolite booster surround. It is, however, a heavier charge, weighing approximately ½ pound.

The stabilizer tube consists of two principal parts: the fuze body, which threads into the union and contains the fuze mechanism, and the powder tube to which the fuze body is permanently joined, and which contains the propellant charge.

The fuze is similar in all its components to that of the AT grenade. It is, however, of heavier construction, as is the entire rocket, and contains heavier booster and detonator charges. The parts of the fuze are a spring restrained striker; a detonator of priming mixture, lead azide, and tetryl; and a booster of tetryl. The striker is held in the unarmed position prior to loading into the launcher, by a safety pin which engages an annular groove in the striker as it passes through opposed holes in the fuze body. The safety pin clips to the stabilizer tube and must be removed prior to firing of the rocket.

The powder tube or remainder of the stabilizer tube in this case serves as a housing for the propellant powder and an electric safety match or squib. The propellant powder is a monoperoforated ballistite type formed into rather long grains. The electric safety match with

## AMMUNITION INSPECTION GUIDE

an igniting charge of black powder is located at the upper end of the powder tube. Two contact wires pass down through the powder tube and out through the nozzle portion of the fin assembly.

The fin assembly consists of three parts: the nozzle, which is a venturi tube; the trap, which is a spider ring closing the nozzle opening above the venturi and holding the propellant powder in place; and finally, the fins themselves. The fins are six metal blades, each spot-welded to the outer surface of the nozzle at two points. Each blade is notched at a point opposite the lower extremity of the nozzle. These notches are unpainted and one of them serves as a contact for the electric safety match, one ignition wire being soldered to it. The other contact is made by means of an insulated (with a fiber strip) brass contact ring encircling the ogive. A brass connector strip runs from the end of the body to this ring. To the end of the connector strip is soldered the other ignition wire from the electric safety match. This ignition wire is taped to the stabilizer tube midway between fins and body.

*Function.* The safety pin is removed and the rocket inserted into the rear opening of the launcher. It is held in place by a safety catch. Firing is accomplished by establishing an electric circuit between rocket and launcher. This causes ignition of the electric safety match, the black powder ignites, and the propellant powder gases issue through the nozzle, the venturi serving to increase their velocity. This back blast serves to propel the rocket forward. There is no recoil and the back blast should not affect the firer since the powder is designed to be completely burned within the launcher. On impact with the target the striker, due to inertia, drives forward overcoming its restraining spring. It strikes and causes detonation of a detonator of priming mixture, lead azide, and tetryl, which in turn carries detonation of a tetryl booster, a 10/90 pentolite booster surround, and a 50/50 pentolite bursting charge.

*Effect.* The rocket has effect against various targets as follows:

1. *Armor plate.* Penetration slightly in excess of 3 inches of homogeneous steel armour plate at all ranges and at angles of impact as low as 60 degrees from normal. A hole, roughly cylindrical and about 1 inch in diameter, is blown through the plate, the force exerted by the detonation being of such high order that the metal of the armor plate is raised to a state of incandescence, and exits from the back of the plate in a spray of several hundred particles. Such a spray is cone-shaped with its angle of opening about 90 degrees. This spray exerts antipersonnel effect to a distance of 30 yards and usually causes explosion of ammunition it strikes.

2. *Masonry.* Penetration of brick walls and rock masonry not over 8 inches in thickness is accomplished with a burst having a powerful blast effect.

## SMALL ARMS AND TRENCH WARFARE

3. *Structural steel.* Shattering effect against cast steels and such materials as girders and railroad rails. Effect against a motor block causes extensive damage, in most cases irreparable.

4. *Wood.* Penetration of up to 9 inches of pine timber, caused by its blast action. Less than 1 inch of wood ordinarily will not cause detonation.

5. *Water.* Water will not cause detonation of the rocket bursting charge.

6. *Soil.* Impact with the ground will not ordinarily cause detonation except at ranges in excess of 300 yards. The trajectory is sufficiently flat to cause the rocket to ricochet at shorter ranges without detonating. At ranges from 300 yards to 650 yards, the extreme range, impact usually does cause detonation except in very soft soil such as mud. Bursts against the ground have much of the blast effect and all of the appearance of 75-mm H.E. shell. However, it will be under the most exceptional circumstances that this type of rocket will ever be employed against personnel in the open.

*Uses.* The primary use of the rocket is of course against tanks, it being highly effective against all known types of medium tanks. It, however, has secondary uses as follows:

1. *Antitank mine.* The rocket is placed, nose up, in a hole in the ground about 2 feet deep, properly placed to achieve the desired effect. It is fired electrically by attaching the ends of two wires to the rocket ignition wires, one to the brass contact ring on the ogive, the other to the fins. Ordinary twisted field telephone wire and the dry-cell battery from the launcher suffice for this purpose. The rocket may be placed in a road bed or set horizontally into the side of a cut or bank.

2. *Demolition.* The rocket may be used for destruction of railroad rails, structural steel, disabled armored vehicles, and various types of material. It may be placed in or near the object to be destroyed, allowance being made for about a foot of travel before impact. Ignition is accomplished as in the antitank mine use.

3. *Booby traps.* When used for this purpose, the rocket should be sited to strike a hard surface such as masonry or heavy timbers to obtain maximum effect of the blast. The ignition would be accomplished as above with a trip wire or similar device to make contact.

**ROCKET, Practice, 2.36-inch, M7.** This rocket is similar in shape, size, and weight to the high-explosive type. However, it is provided with only a propellant charge, the head being inert. No fuze is provided. The end of the stabilizer tube is extended to counter-weight the head and make the ballistics of this rocket similar to that of the H.E. type. A safety pin passes through the stabilizer tube



## AMMUNITION INSPECTION GUIDE

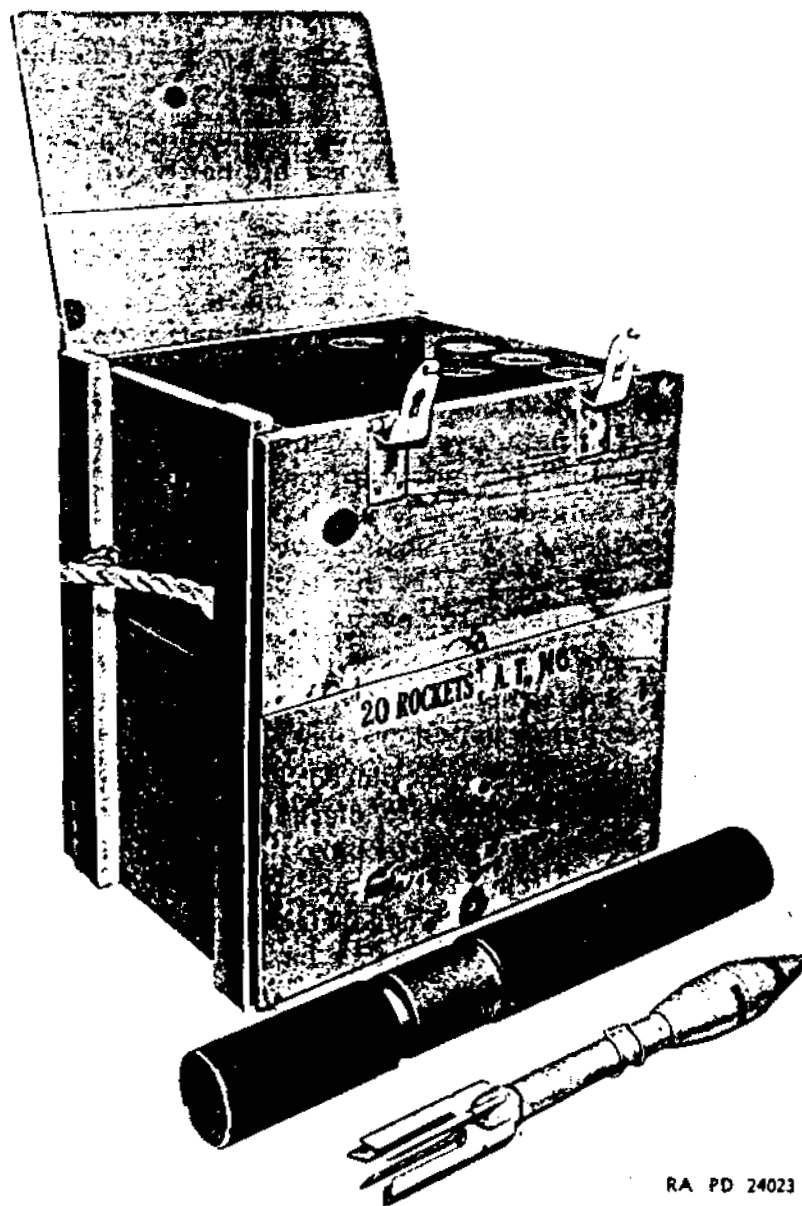

RA PD 24023

**Figure 102 — Packing of ROCKET, AT, M6**

at the upper end and in order to make the detail of firing this rocket similar to that necessary in the above H.E. type. Since there is no fuze, it naturally serves no useful function. In all other respects the rocket is similar to the H.E. type. It is used for target practice only.

**Painting and Marking.** The M6 Rockets (H.E. type) are painted a lustreless olive drab and stenciled in yellow, while the practice type (the M7) is painted black and stenciled in white. The stencil in each case includes the type, model, and lot number.

TM 9-1904

**SMALL ARMS AND TRENCH WARFARE**

**Packing.** Each of the above types is packed 1 per fiber container, 20 containers (20 rockets) per box.

**FURTHER REFERENCES:** TM 9-294, TM 9-1900; FM 23-30; TC 104; SNL S-4, SNL S-9.

---

---

## Chapter 7

### Trench Mortar Ammunition

#### HISTORY.

Experience in World War I emphasized the need of more extensive and efficient artillery for the support of the land army. The infantry needed a weapon which would support it when it outdistanced its artillery forces. The artillery was merely able to give initial support. This resulted in terrific massacres of the infantry with the loss of what had been gained. Some attempts were made to increase the offensive power of the infantry by attaching field artillery batteries and guns. However, flat trajectory weapons did not supply the answer to the problem. The enemy dug in and the shells passed over the trenches or hills where they were located. In addition, a 550-yard minimum range of the artillery weapon and a 50-yard maximum range of the hand grenade produced a definite void.

The earliest form of the trench mortar weapon was a crude affair. It consisted of an arrangement of pipes and supports. Crude missiles were hurled at the enemy by propelling charges. At the time of entry into World War I, the United States did not number the trench mortar as one of its standard weapons. Britain, however, had adopted a standard 3-inch trench mortar weapon known as the Stokes Mortar. This weapon had a high angle of fire, short range, and short barrel. It was muzzle loaded and had a smooth bore. It fired a projectile weighing 11.7 pounds a maximum distance of 750 yards. This weapon at the time was the answer to a great need. It gave a decent range

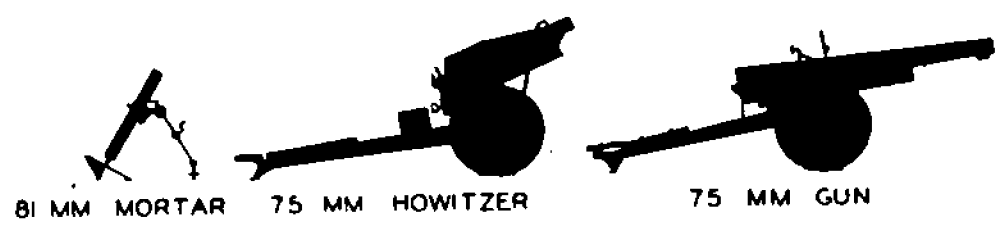
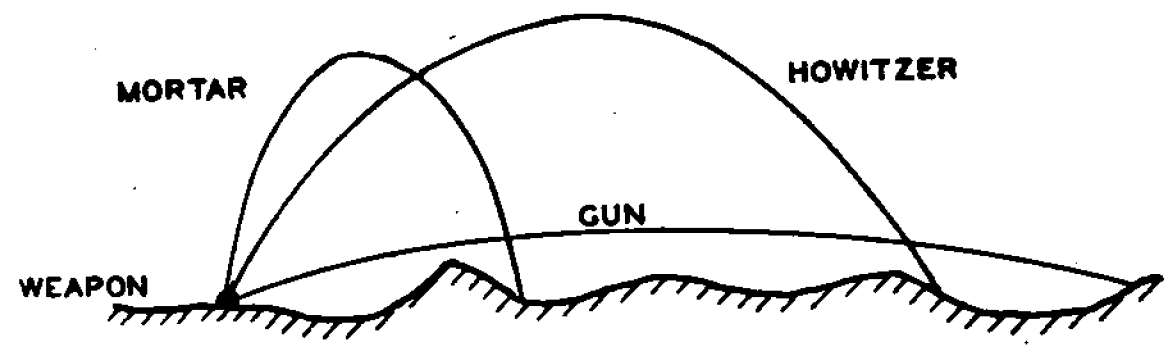

81 MM MORTAR

75 MM HOWITZER

75 MM GUN

RA PD 15197

Figure 107 — Weapons and Trajectories

## AMMUNITION INSPECTION GUIDE

and much better accuracy than the crude affair of pipes. The weapon served its purpose in that it supplied the needed support for the infantry that the artillery fire lacked, and it served to blast out machine gun nests, barbed wire entanglements and other obstructions. It also proved its efficiency by being a light weapon, firing a fairly heavy shell, being simple to manufacture and easy to carry.

**Brief Comparison of Weapons.** The classification of gun, howitzer, and mortar no longer conveys the precise meaning it once did. As formerly defined, a gun was a long, high-velocity weapon fired at elevations not exceeding 20 degrees; a howitzer of equal caliber was a shorter, lighter weapon, firing at higher elevations than the gun with less velocity, and at targets that could not be reached by direct force; the mortar was still a shorter weapon designed to fire at elevations up to 65 degrees and to give plunging fire on the targets. The distinction between gun and howitzer is less marked. The modern gun carriage permits firing at high elevations. For example, the 16-inch seacoast gun can be fired at elevations up to 65 degrees, and antiaircraft guns can fire up to 85 degrees. On the other hand, the increased ranges demanded of howitzers have necessitated longer, heavier weapons to produce the velocities required. The factors of weight and mobility, however, still justify provision of distinctive gun, howitzer, and mortar types of mobile artillery. Considering equal calibers, the gun will have the highest velocity, longest range, and least mobility.

### **Purpose of the Trench Mortar Weapon.**

1. To tear down barbed wire entanglements.
2. To blast troops out of trenches.
3. To destroy obstructions.
4. To reach dead space behind hills.

### **3-INCH TRENCH MORTAR AMMUNITION.**

**General.** The 3-inch trench mortar shell consists of a cylindrical steel casing, having a steel base and steel head screwed on at each end of the casing. The steel head serves to close the nose of the shell, and also seats the booster jacket and fuze. The steel base serves to close the tail end, and seats the cartridge container. Depending on the type of shell, the filler will either be TNT, WP, or inert filler with black powder to act as a spotting charge.

The booster jacket which is seated in the steel head consists of a 1-piece drawn steel cup with a supporting flange formed on one end. It serves to seat the booster charge consisting of mercury fulminate, tetryl, and TNT; or, in case of the practice shell, black powder. The fuze which screws into the head is known as the Mk. VI, all-ways percussion fuze. "All-ways," because this fuze is designed to

## SMALL ARMS AND TRENCH WARFARE

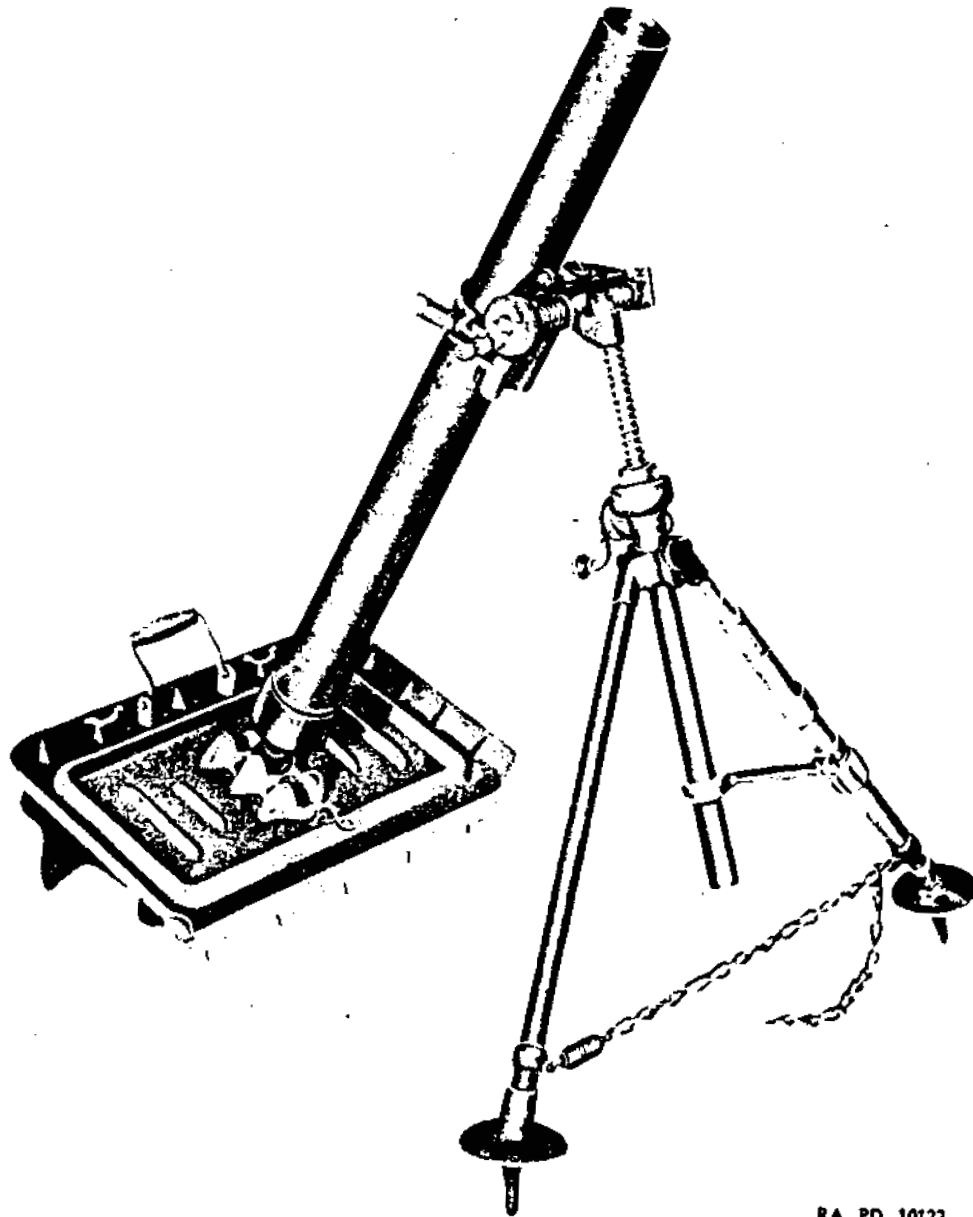

RA PD 10122

**Figure 108 — 81-mm Mortar**

function regardless of what position the shell may land, on nose, tail, or side. "Percussion," because this fuze has no detonating element in it and functions on impact action. This fuze must be used on 3-inch trench mortar shell because the shell is unstable in flight and may land in any position.

The cartridge container consists of a short, steel tube threaded at one end so as to screw on the steel base. The interior of the cartridge container is hollow, and into this cartridge container fits an

## AMMUNITION INSPECTION GUIDE

ignition cartridge. Sixteen holes are drilled through the walls of the cartridge container to permit the escape of gases after the ignition cartridge is fired, and also to allow the ignition of powder rings which are placed around the outside of the cartridge container.

The propelling charge consists of two main units:

1. The ignition cartridge.
2. Powder rings.

*The ignition cartridge.* This is known as the Mk. I green cartridge and is similar in appearance to a blank shotgun shell. It consists of a cardboard cylinder, which has a brass base containing a primer. The rest of the ignition cartridge consists of 120 grains of loose ballistite sporting powder. The ignition cartridge fits into the cartridge container so that the primer fits flush with the end of the container, and when the shell is dropped into the weapon the primer strikes the firing pin of the trench mortar weapon. The flame produced from the primer ignites the ballistite powder which propels the shell a distance of 150 yards.

*Powder rings.* The powder rings consist of ring-shaped, silk cloth bags, each loaded with 100 grains of ballistite or 110 grains of MR No. 31 powder. The rings fit around the outside of the cartridge container and are ignited by the flame from the ignition cartridge. The shell may be fired by using the ignition cartridge alone, which permits a range of 150 yards, or may be fired by using the cartridge, and one, two, or three powder rings, depending upon the range desired. This permits four zones of fire, giving ranges of approximately 150 yards to approximately 750 yards. Zone 1 firing is conducted by using the cartridge only; zone 2, by using the cartridge and one powder ring; zone 3, by using the cartridge and two powder rings; and zone 4, by using the cartridge and three powder rings. The number of powder rings to be used is determined by the range desired. More than three powder rings are never used, as excessive pressure would be developed which might burst the mortar. Zone 4 is within the working pressure of the mortar, but use of this charge is recommended only in case of necessity.

**Types of Ammunition:** H.E. shell, chemical shell, and practice shell.

**Class of Ammunition.** *Semifixed.* Although all the ammunition is designed to be loaded into the weapon in one operation, provisions are made for adjusting the propelling charge at the point of fire.

**Packing.** The 3-inch trench mortar shell is sent to the field as un-assembled, complete rounds. Three un-assembled complete rounds are packed per wooden box, with one extra propelling charge (a total of 12 powder rings and 4 ignition cartridges).

SMALL ARMS AND TRENCH WARFARE

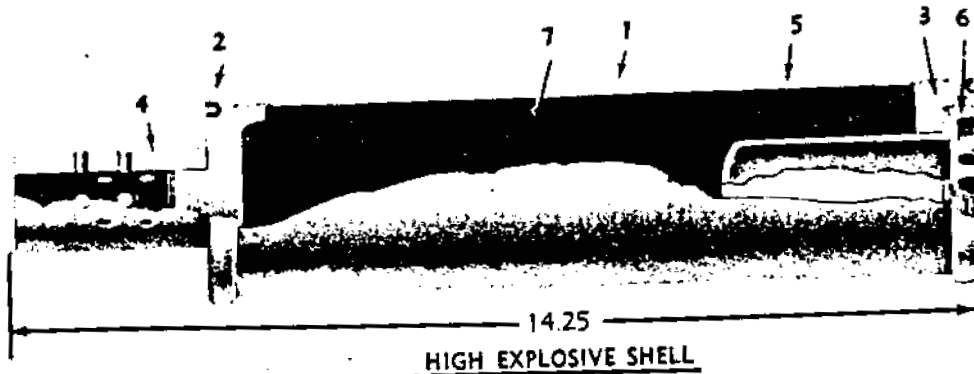

HIGH EXPLOSIVE SHELL

- |                         |                            |
|-------------------------|----------------------------|
| 1 — CASING              | 5 — BOOSTER JACKET         |
| 2 — BASE                | 6 — FUZE HOLE PLUG         |
| 3 — HEAD                | 7 — EXPLOSIVE FILLER (TNT) |
| 4 — CARTRIDGE CONTAINER |                            |

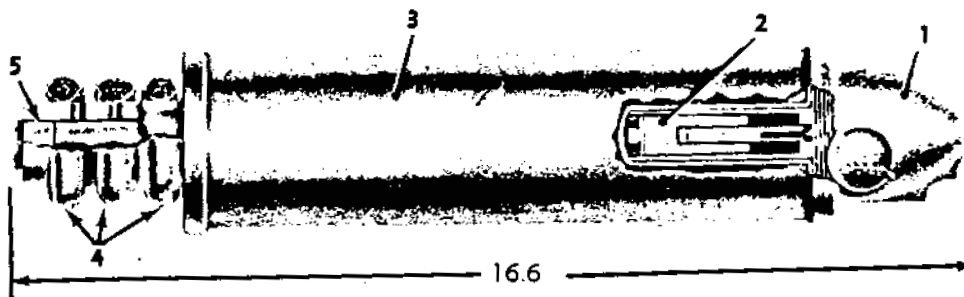

COMPLETE ROUND

- |             |                  |
|-------------|------------------|
| 1 — FUZE    | 4 — POWDER RINGS |
| 2 — BOOSTER | 5 — CARTRIDGE    |
| 3 — SHELL   |                  |

RA PD 15199

Figure 109 — 3-inch and 81-mm Trench Mortar Ammunition Mk. I



**AMMUNITION INSPECTION GUIDE****81-MM TRENCH MORTAR.**

**General.** The first attempt to obtain more efficient trench mortar ammunition was with the development of the 75-mm smooth bore mortar in which the old 75-mm French type shell was modified by tapering the shell from the bourrelet back to the base, and fitting an aluminum fin in the base of the shell. The round was propelled by means of an ignition cartridge inserted in a short cartridge case, and with propelling increments inserted between the blades of the fin. The stability of the round was not satisfactory, and the development was abandoned. A streamlined projectile with fin assembly was then designed for the 3-inch trench mortar with poor results. Several attempts were made with shell of different contours, but proved unsatisfactory because proper stability was not obtained.

After World War I, there was an early trend away from the low powered, muzzle-loading Stokes mortar to breech and rifled mortars which were mounted on wheels. The muzzle velocity, the range, and the weight increased, but in so doing, the effectiveness of the trench mortar was decreased in that it lost its simplicity. The weapon became too cumbersome and unwieldy.

Meanwhile the Edgar Brandt Company worked on the 81-mm trench mortar which turned out to be simple in design, utilizing ammunition which was stable in flight and had a long range. In 1931 and 1932, tests conducted by the War Department proved that this mortar and ammunition were highly satisfactory. In 1932, manufacturing rights were purchased from Brandt Company. The weapon itself was a refinement of the 3-inch trench mortar, consisting mainly of a cross leveling mechanism, a better sight, and a heavier baseplate. For simplicity and effectiveness, this mortar proved a remarkable weapon.

**Advantages of 81-mm over 3-inch Trench Mortar Ammunition.**

1. The 81-mm ammunition is more stable in flight.
2. The 81-mm ammunition has a longer range.
3. The 81-mm ammunition comes to the firing line assembled, ready for use.
4. The 81-mm ammunition utilizes a point detonating fuze.

**Types of 81-mm Ammunition:** High-explosive shell, chemical shell, practice shell, and training shell.

**Class of Ammunition.** 81-mm ammunition is classified as semi-fixed; although the ammunition is designed to be loaded into the weapon in one operation, provisions are made for adjusting the propelling charge at the point of fire.

**Description.** The ammunition itself is streamline in design. It has a stabilizer assembly in the rear of the shell to produce stability in flight and to seat the propelling charge. The stability adds to the

## SMALL ARMS AND TRENCH WARFARE

range, velocity, and accuracy of the projectile, and causes the projectile to strike point first, allowing the use of a point detonating fuze. It comes assembled with fuze, propelling charge, and ignition cartridge in place. The only operation necessary before loading the shell into the weapon is to remove the round from its fiber container and then pull the cotter pin or safety wire from the fuze and drop shell into the weapon.

**SHELL, H.E., M43.** The shell was originally adapted as the light shell for the 81-mm mortar. It is designed for use against light targets such as machine gun nests, barbed wire entanglements and personnel in the open.

*Shell body.* The body of this shell is constructed of forged steel. It is tear-dropped in shape; that is, blunt nose and tapered tail. It has a bourrelet machined near the nose of the shell consisting of several annular grooves which serves to act as a forward bearing surface and a gas check. The action of the propelling charge gases expanding in the grooves and contracting to pass the raised portions tends to slow the gases and prevent their passing the bourrelet. The nose is machined and threaded to receive an adapter. The adapter is threaded and acts as a bushing for a bakelite fuze well cup and the fuze. The bakelite fuze well cup is fitted to the adapter before it is assembled to the shell body and prevents the entrance of foreign material into the fuze cavity prior to the assembly of the fuze to the round. The fuze used is the Point-detonating Fuze M45. This fuze has a selective element and can be set for either superquick or delay action. (For details, see pages 295 to 298.) To the rear of the bourrelet is a curved taper reducing the base of the shell to approximately 1½ inches. The base is closed and machined so as to receive a stabilizer assembly. The shell filler is 1.22 pounds of TNT. The total weight of completely assembled round is 7.05 pounds. Entire length of the fuzed shell is 13¼ inches.

*Fin assembly.* The fin assembly consists of a machined cartridge container to which are attached six stationary fins. One end is closed and threaded so as to be screwed on to the body of the shell. The other end is machined and hollow inside so as to receive the ignition cartridge. Several holes leading from the interior to the exterior periphery of the cartridge container serve to conduct the flames from the ignition cartridge to the propellant increments which are seated in the fins.

*The ignition cartridge.* The Ignition Cartridge M3, red, is similar in appearance to a shotgun shell; the head is of brass and contains the percussion primer; the body is of cardboard, red in color, and contains 120 grains of finely granulate double base powder. It is designed to fit into the hollow portion of the stabilizer assembly.

## AMMUNITION INSPECTION GUIDE

*The propellent increments.* The propellent increments are in the form of small half-round celluloid increments. These increments are often referred to as "chocolate drops" due to their similar shape. Each of these increments contains 100 grains of finely granulated double base powder.

A total of one ignition cartridge and a set of increments comprise the full propelling charge (720 grains of ballistite). The increments are held in the stabilizer assembly by small flanges on the fins and may be removed to adjust the propelling charge.

*Zones of fire and range.* This shell has seven zones of fire. The first zone of fire consists of the ignition cartridge. Zone seven consists of the ignition cartridge and six increments.

Zone one has a range of approximately 100 yards.

Zone seven has a range of approximately 3,300 yards.

*Marking and packing.* The shell body is painted olive drab lustreless with yellow stencil to indicate H.E. filler. The stenciling includes the following information: caliber of weapon, kind of filler, model number of shell, and ammunition lot number.

For storage, shipment, and issue this shell is packed as a complete assembled round with the fuze and propelling charge in place.

It is packed one round per individual fiber container, six containers per bundle. Weight of a full bundle is 59 pounds. It may also be packed one per individual fiber container, eight containers per wooden box. Weight of a full box is 91 pounds.

Individual fiber containers are sealed with adhesive tape. The color of the tape and stenciling indicate the type of the shell inside.

Metal plates are placed on the ends of each packing bundle. One plate gives the number of rounds contained in the bundle, the nomenclature of the rounds, the lot number, and initials of the loading plant. The plate at the opposite end gives the proper shipping name as listed in SNL R-4, the total weight of the loaded bundle, and cubic displacement.

Packing bundles are held together by a rod passing through the center of the bundle with a wing nut at the end. After assembling, each bundle is sealed with a wire and lead seal. If this seal has not been broken, the bundle may be considered as the original package, positively identified by the metal plates at the ends of the bundle and by the marking of the fiber container.

**SHELL, H.E., M43A1.** This shell was designed to replace SHELL, H.E., M43. It is standard for issue and manufacture (S & M), whereas the SHELL, H.E., M43, is standard for issue (S).

*Shell body.* The body, filler, adapter, and bakelite fuze well cup are exactly the same as in the M43. The fuze used is the Point-detonating Fuze M52, which has a superquick action. Due to the light

**SMALL ARMS AND TRENCH WARFARE**

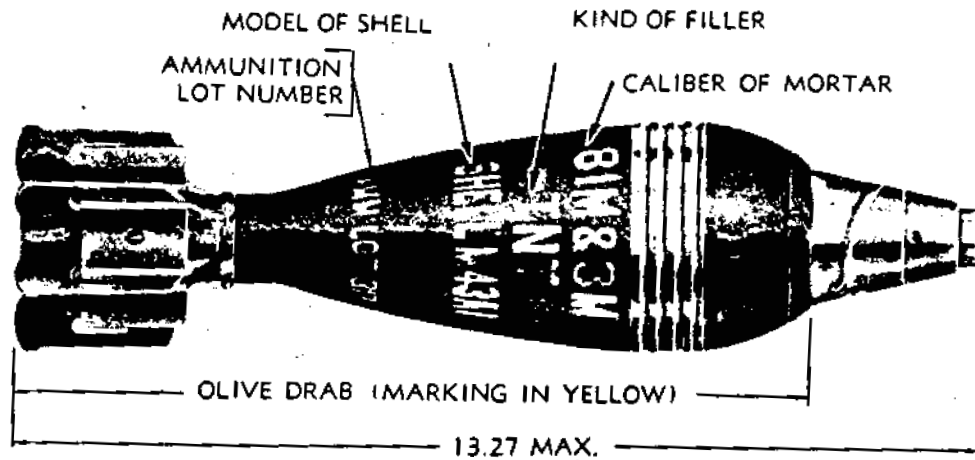

RA PD 7232B

**Figure 110a — SHELL, H.E., M43A1, 81-mm Mortar**

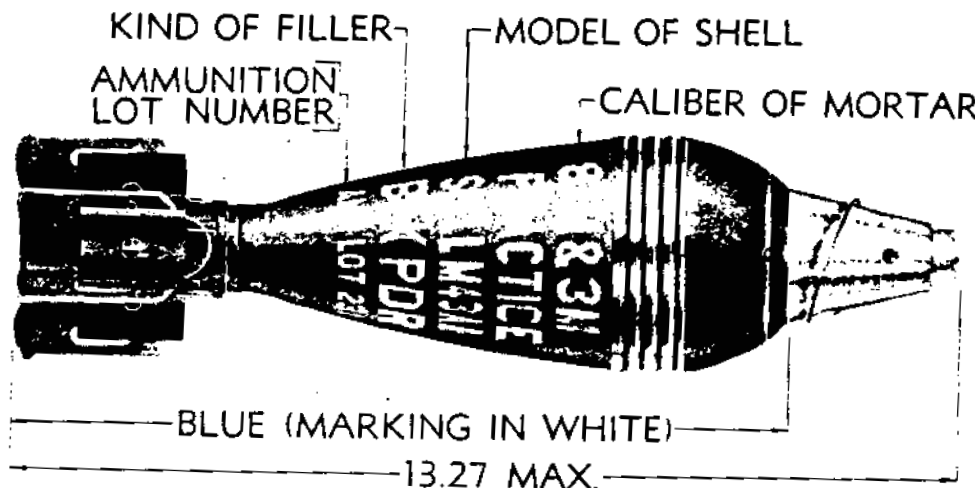

RA PD 7235A

**Figure 110b — SHELL, Practice, M43A1, 81-mm Mortar**

weight and blunt nose of this shell, very little penetration can be obtained. This shell, as the M43, is designed, therefore, to produce fragments as its primary function against personnel in the open and against barbed wire entanglements. Fragments to be effective must be above ground. The use of a superquick fuze to burst the shell above ground is therefore mandatory. For details in the functioning of the M52 P.D. Fuze, see page 298 to 300.

*Fin assembly.* The fin assembly is similar to that previously described. It differs in that the flanges on the fins for holding the propellant increments are omitted, as they are not necessary with the newer type increments. Later models, without any change in designation, have the hollow end threaded in the inside so as to receive the new percussion primer.

**AMMUNITION INSPECTION GUIDE**

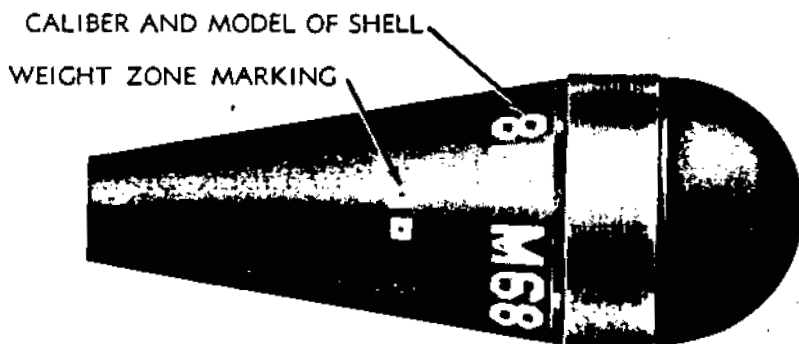
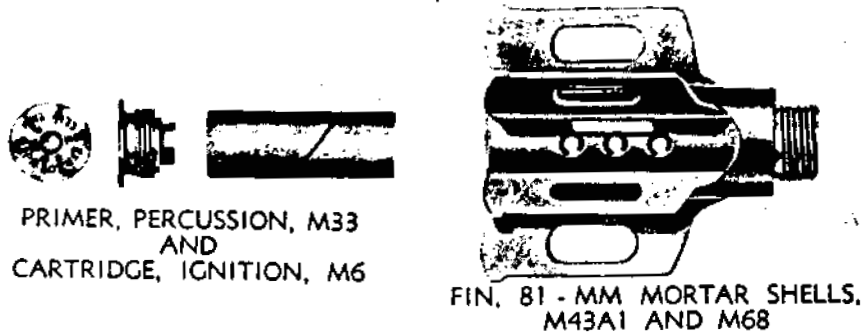

SHELL, TRAINING, M68, 81-MM MORTAR,  
W/O FIN, IGNITION CARTRIDGE, AND PRIMER

A — COMPONENTS

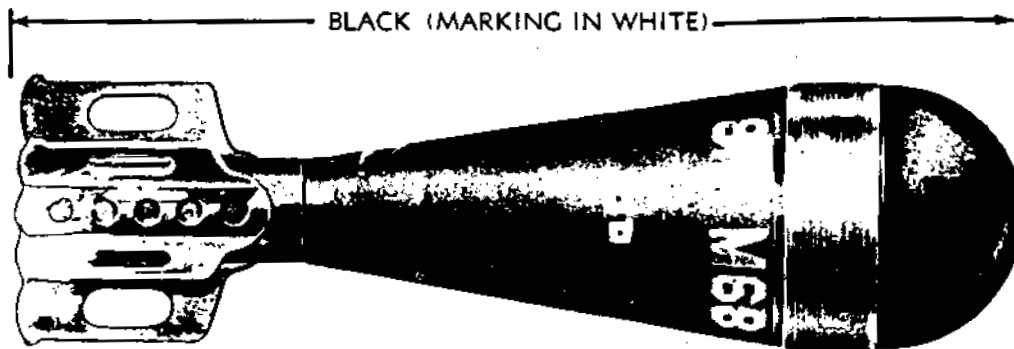

B — ASSEMBLED

RA PD 8077B

**Figure 110c — SHELL, Training, M68, 81-mm Mortar**

## SMALL ARMS AND TRENCH WARFARE

*Ignition cartridge.* The Ignition Cartridge M6, red, consists of a cardboard container having approximately 120 grains of double base powder. It supersedes the M3 red and differs from it in that the percussion primer is no longer part of the ignition cartridge but a separate component.

*The percussion primer.* The Percussion Primer M33 is a relatively new component. The percussion primer is contained in an aluminum head and is threaded so as to screw into the end of the cartridge container after the ignition cartridge has been inserted. The advantage of this type of percussion primer and ignition cartridge is that the whole assembly will leave the mortar with the shell whereas the older type ignition cartridge would, due to the force of setback, at times leave its brass head in the trench mortar weapon, fouling the firing pin and possibly causing a misfire in subsequent rounds.

*Propellant increments.* The Propellant Increment M1 consists of square strips of double base powder sewn together to form increments. Passing thru these increments will be found holes to increase the burning surface. These sheets are thin and flexible and will not crumple or break as did the old celluloid containers of double base powder used with the M43 Shell. Each increment has 117 grains of double base powder. Occasionally one corner edge of an increment will be cut away (notched) so as to bring the charge to the desired weight and specification. The increments are held in the stabilizer assembly by being placed diagonally in the holes of the fins.

The percussion primer, ignition cartridge and six increments make up the full propelling charge of a total of 822 grains of powder. The increments may be removed to adjust the propelling charge.

*Zone of fire and range.* This shell has the same number of zones of fire and approximately the same range as described for SHELL, H.E., M43.

*Marking and packing.* The shell body is painted olive drab with yellow stencil. It is packed one per individual fiber container, six fiber containers per bundle, one bundle per wooden chocolate-stained crate for overseas shipment. The rounds are completely assembled, ready to fire.

**SHELL, Practice, M43A1.** SHELL, practice, M43A1, is similar to SHELL, H.E., M43A1. The shell body, components used, and packing are identical to the shell previously described. It differs in that the filler consists of 0.16 pound of black powder to act as a spotting charge, and 1.06 pounds of inert filler such as wax, talcum, or rosin which will not crack up in handling. The body is painted blue with white stencil to indicate a practice shell.

AMMUNITION INSPECTION GUIDE

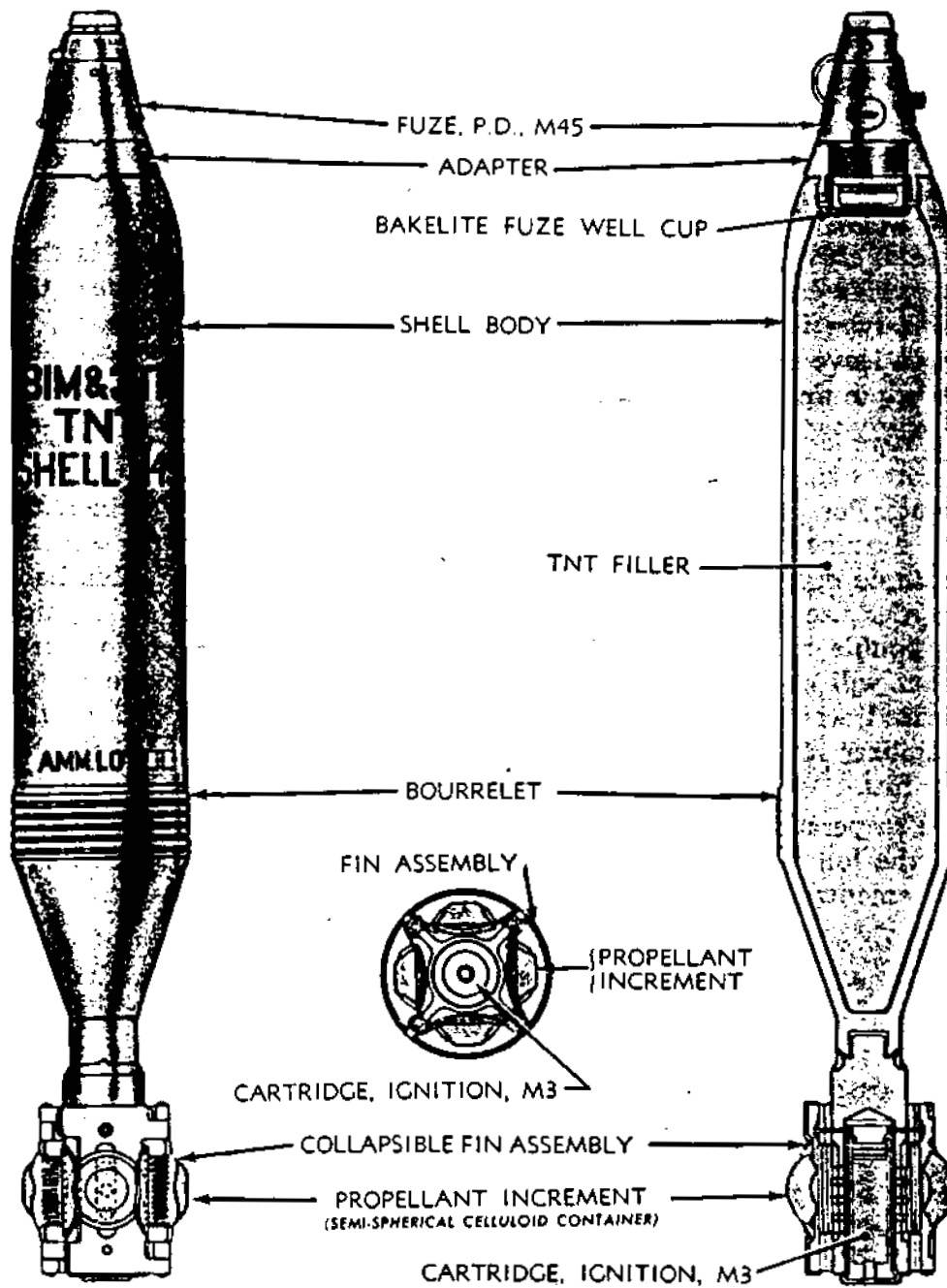

RA PD 22901

Figure 111 — SHELL, H.E., M45, 81-mm Mortar  
284

**SMALL ARMS AND TRENCH WARFARE**

**SHELL, Practice, M44.** This shell is used for practice firing in the 81-mm trench mortar weapon.

The body of the shell is made of cast iron and contains an inert filler. A small amount of black powder (0.20 pound) is placed below the fuze to give a spotting effect when the fuze functions. The body shape, size, and weight are identical to the M43 Shell. It has no adapter, however. The fuze screws directly into the nose of the shell.

The shell body is painted blue with white stencil and is packed in the same manner as SHELL, H.E. M43.

**SHELL, H.E., M45.** This shell is one of the early types adopted for use in the 81-mm mortar. At the present time, this shell is standard for issue but not standard for manufacture. The principal use of this shell is against dugouts, heavy barricades, and underground structures where a mining action is most effective.

*Shell body.* The body of this shell is constructed of forged steel. It is cylindrical in shape, having a tapered nose and tail. It has a bourrelet machined on the body near the tail which serves as a rear bearing surface and a gas check. There is no bourrelet at the front of the shell. The nose is threaded to receive an adapter.

The adapter is threaded to receive the fuze well cup and fuze. The use of an adapter bushing allows the shell to be loaded with less difficulty and also permits the use of the same fuze for the 81-mm and 60-mm shells. The fuze used is the P.D. M45 having a selective setting for either superquick or delay action. For details as to functioning of the M45 Fuze see pages 295 to 298. The base of the shell is closed and threaded so as to receive a stabilizer assembly. The shell filler is 4.48 pounds of TNT. The total weight of the completely assembled round is 15.10 pounds. The entire length of the shell is 23½ inches.

*Fin assembly.* The fin assembly consists of a machined cartridge container to which are attached collapsible fins. One end of the cartridge container is closed and threaded to be screwed on the body of the shell. The other end is machined and hollow inside to receive the ignition cartridge. Holes in the cartridge container act to lead the flame from the ignition cartridge to the propellant increments.

The propellant increments are held in place by the collapsible fins. The fins are always being forced into their open position by compressed springs. The fins are kept in position before firing by a small copper wire tied around them. The blast of the propelling charge shears the copper wire and permits the fins to open to a greater diameter than the shell body after it has cleared the muzzle of the weapon. This was designed to increase the stability of the shell by increasing the fin surface.



## AMMUNITION INSPECTION GUIDE

This type of fin assembly has not proved successful for several reasons:

During storage the springs which are always compressed will lose their tension or become set.

The fins, due to their size, are delicate and the blast of the propelling charge explosion will in many cases cause distortion.

Both of the above reasons tend to result in unstable flight and the purpose for which this stabilizer assembly was designed is defeated.

*The ignition cartridge.* The ignition cartridge is the M3 red previously described.

*The propellant increments.* The propellant is in the form of half-round celluloid increments previously described.

A total of one ignition cartridge and four increments comprise the full propelling charge of 520 grains of double base powder.

The propelling charge may be adjusted to vary the range.

*Zones of fire and range.* This shell has five zones of fire. The first zone of fire consists of the ignition cartridge itself. Zone five consists of ignition cartridge and four increments.

Zone one has a range of approximately 100 yards.

Zone five has a range of approximately 1,275 yards.

*Marking and packing.* The shell body is painted olive drab lustreless with yellow stencil to indicate H.E. filler.

The shell is packed as complete and assembled rounds for storage, shipment, and issue in the following manner:

One per individual fiber container, three rounds per bundle, or one per individual fiber container, four rounds per wooden box.

**SHELL, H.E., M56.** This shell was developed to replace the H.E. Shell M45 and is standard for issue and manufacture (S & M). It is used against dugouts, barricades, and underground structures where a mining action is desired. This shell is a much more effective one than the M45 due to the fact that it contains approximately 40 percent explosive filler as compared to 30 percent explosive filler of the M45. The greater the percentage of explosive filler, without sacrificing the penetrating ability of the shell body, the more effective is the shell when used for mining effect.

*The shell body.* The shell body is constructed of forged steel. It is long and cylindrical in shape with a tapered nose and tail. It has a bourrelet machined on the body near the base of the shell which acts as a rear bearing surface and a gas check. There are three raised portions around the shell near the nose to act as a forward bearing surface. The nose is machined and threaded to receive an adapter. The adapter is threaded to receive a fuze well cup and fuze. The fuze used is the M53 P.D. which has a delay in action on impact. For mining effect, penetration of the target produces the most effective

SMALL ARMS AND TRENCH WARFARE

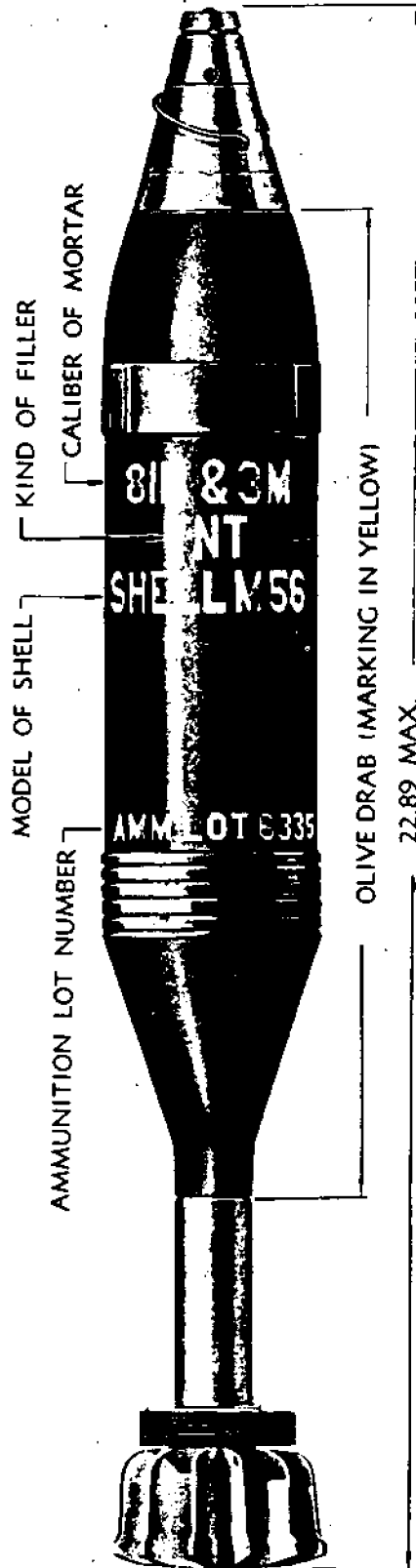

RA PD 7334A

Figure 112 — SHELL, H.E., M56, 81-mm Mortar

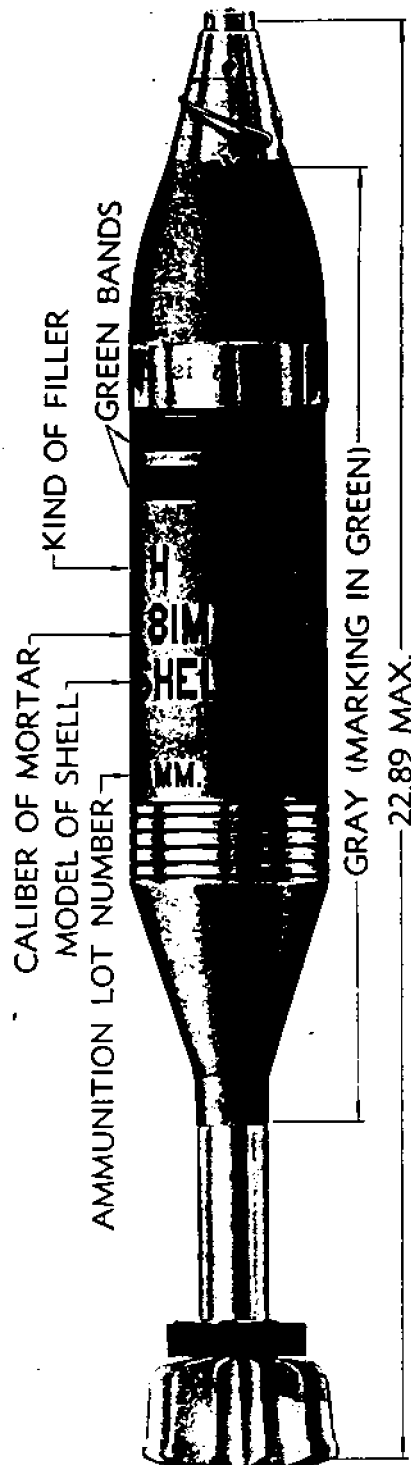

RA PD 7331A

Figure 113 — SHELL, Gas, Persistent, H, M57, 81-mm Mortar

**AMMUNITION INSPECTION GUIDE**

results. The use of a delay action fuze, therefore, to allow penetration is mandatory. For details of functioning of the M53 P.D. Fuze, see page 300 to 303. The base of the shell is closed, machined, and threaded to receive the stabilizer assembly. The shell filler consists of 4.31 pounds TNT. The weight of the completely assembled round is 10.77 pounds. The entire length of the shell with fuze assembled is 22.89 inches.

*The fin assembly.* The fin assembly consists of a long stem and cartridge container made of aluminum alloy. Having stationary fins formed at the open end of the cartridge container, the stem is closed and threaded so as to be screwed to the shell body. The cartridge container which is part of the same unit is hollow, machined, and threaded at the open end to receive the percussion primer. There are holes in the cartridge container near the fins so as to conduct the flames from the ignition cartridge to the propellant increments which fit around the cartridge container.

*The ignition cartridge.* The earlier shell of this model used the M3 Ignition Cartridge red. The later shell of the same model had the fin assembly threaded so as to receive the M6 Ignition Cartridge and percussion primer.

*The percussion primer.* The Percussion Primer M34 is of the same construction and shape as the M33 previously described except that it has a greater diameter.

*The propellant increments.* The Propellant Increment M2 is made up of thin square sheets of double base powder sewn together. A hole of the same diameter as the stem of the fin assembly is cut in the center of the increment and a slit runs to the outer edge so that the increments can be easily attached to the stem or removed to adjust the propelling charge. In the latest manufacture, however, the increments are held in place by a star shaped spring wire clip known as a propellant holder. Each increment has 205 grains of double base powder.

The percussion primer, ignition cartridge, and four increments comprise the field propelling charge; a total of 940 grains of powder.

*Zone of fire and range.* The shell has five zones of fire. The first zone of fire consists of the ignition cartridge and percussion primer; zone five consists of the ignition cartridge, percussion primer, and four propellant increments.

Zone one has a range of approximately 300 yards.

Zone five has a range of approximately 2,655 yards.

*Marking and packing.* The shell body is painted olive drab with yellow stencil. It is packed one per fiber container, three fiber containers per bundle, and one bundle per wooden crate for overseas shipment. The rounds are completely assembled ready for fire.



## AMMUNITION INSPECTION GUIDE

**SHELL, Chemical, M57.** This shell is used for the placing of smoke screens and gas clouds with a secondary incendiary effect when WP is used as its chemical filler.

*Shell body.* In general construction, this shell body has the same outer characteristics as the High-explosive Shell M56. The nose of the shell is threaded to receive the type of adapter peculiar to chemical shell. The adapter is threaded internally to receive the Point-detonating Fuze M52 which has a superquick action. All chemical shell to produce efficient dispersion of filler must burst above ground. A superquick action fuze is therefore used to produce such action. For details, in function of the M52 P.D., see pages 298 to 300.

The chemical filler is loaded into the shell body, and then the burster casing is pressed in place. The head of the Burster Casing M2 is wider than the body of the burster casing and has a slight taper; when pressed into place in the adapter sleeve it forms a gas-tight seal and acts as a seat for the burster charge. A recess is machined in the base of the shell body internally so as to receive the end of the casing, preventing it from becoming loose due to the shock and jars incident to shipment. During the loading of the chemical filler and the pressing of the burster casing in place, there is no explosive charge present in the casing.

The Burster Charge M1 consists of tetryl pellets or tetrytol in a thin aluminum or cardboard cylinder. It is placed in the burster casing prior to the assembly of the fuze to the shell. This construction burster as compared to the old booster found in the 3-inch smoke shell is much more efficient. The explosive charge runs through the entire length of the shell and splits the shell from nose to tail upon function of the fuze, allowing for the dispersion of all the chemical filler in the shell. The old booster charge found in 3-inch smoke shell split the shell near the nose where the booster charge was located, and allowed a good deal of the chemical filler to remain in the base of the shell.

The fin assembly, ignition cartridge, propellant increments, and percussion primer are identical to those used with the High-explosive Shell M56.

Three chemical fillers are loaded at the present time; WP smoke, FS smoke, and H gas. The weight of the completely assembled round varies with the filler used. The weights of the various rounds are:

Filler	Weight of Filler (lb)	Weight of Completely Assembled Round (lb)
WP	4.04	11.50
FS	4.59	12.00
H	3.15	10.45
	290	

## SMALL ARMS AND TRENCH WARFARE

The total length of the shell with the fuze assembled is 22.89 inches.

*Marking and packing.* Shell loaded with WP and FS are painted a blue-gray base color with yellow stencil and one yellow band to indicate a nonpersistent screening smoke filler. Shell loaded with H are painted a blue-gray base color with green stencil and two green bands indicate a persistent toxic filler.

Packing is the same as for M56 High-explosive Shell.

**SHELL, Training, M68.** The shell is designed to give the mortar crew training in loading the weapons and practice in firing under conditions which will not permit firing in more than the first zone.

*Shell body.* The body of the shell is cast iron. It is similar in shape to the light H.E. 81-mm shell which is tear-drop with a blunt nose and tapered tail. It has a bourrelet on the body near the nose to act as a forward bearing surface and gas check. At the tail end is a recess which is threaded to receive a stabilizer assembly. The nose end is closed and rounded with no provisions made to receive a fuze. Its weight varies depending on its weight zone. Nine weight zones are used with a minimum of 9.50 pounds for weight zone one, and a maximum of 10.10 pounds for weight zone nine, weighed without fin assembly and ignition cartridge.

*The fin assembly and propelling charge.* The fin assembly is of the same construction and shape as previously described. It receives the Ignition Cartridge M3. Several ignition cartridges are provided with each round so that the shell can be fired more than one time. There are no propellant increments used because the shell is designed to be fired in the first zone only. The maximum range is 350 yards.

*Marking and packing.* The shell is painted black with white stencil. On the shell body may be found a number of white squares (one to nine) with a prick punch mark in the center of each to indicate the zone weight.

Information as to the packing of the shell is not available at the present time. However the complete round comes in separate units consisting of shell body, ignition cartridge, and fin assembly.

## TRENCH MORTAR FUZES.

**General.** The fuzes used with the 81-mm and the 60-mm mortar ammunition are, except for the 60-mm illuminating shell, of the point-detonating type. The stability of the shell in flight allows the use of this type of fuze. The M45 Fuze, first used on the M43, M44 and M45 Shells, is a point-detonating fuze having a selective feature which allows the fuze to be set for either superquick or delay as desired. The superquick action is used for effect against **D-6e**

292

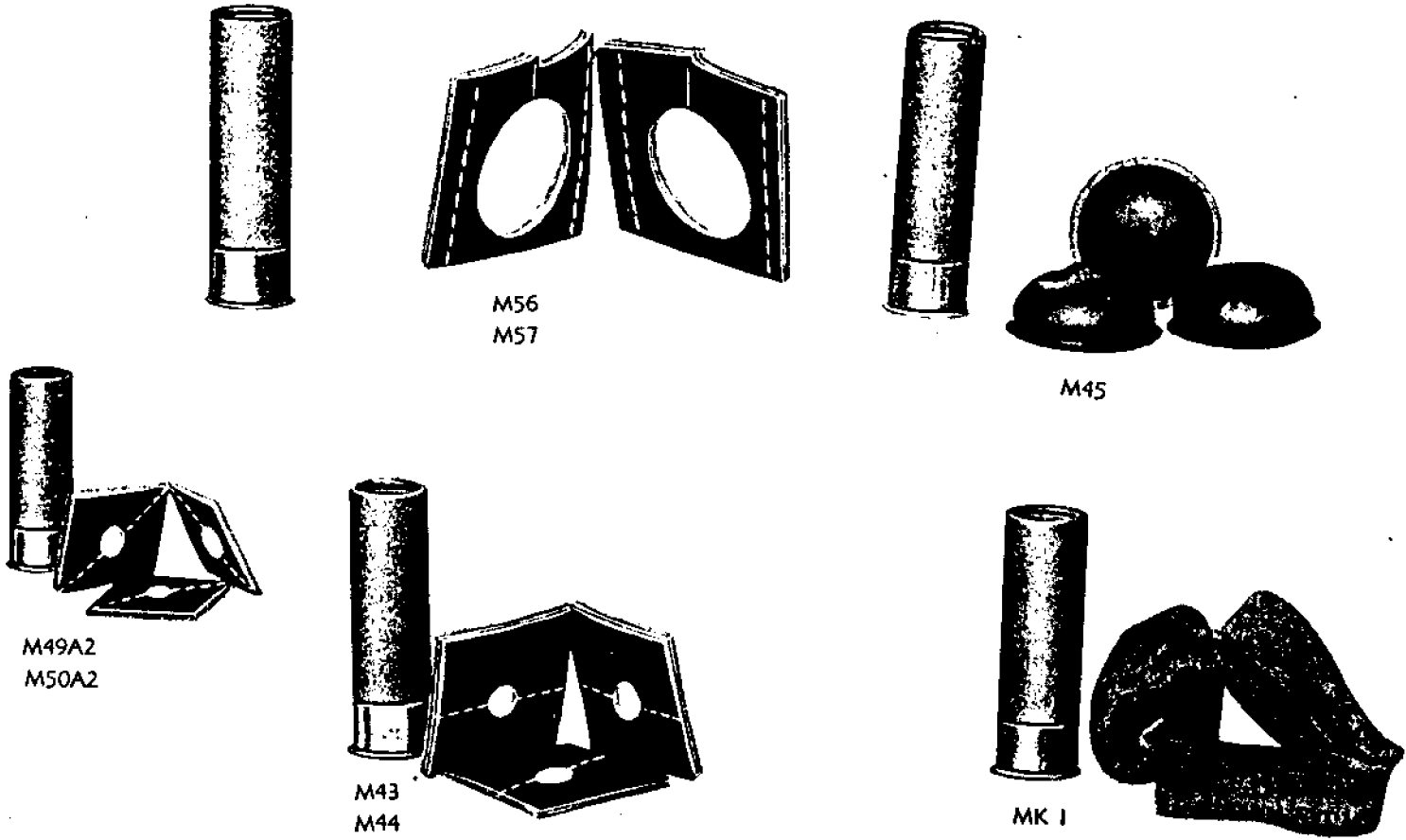

Figure 115 — Trench Mortar Propellants

RA PD 22903

## SMALL ARMS AND TRENCH WARFARE

targets above the ground where no penetration is necessary, and a fragmentation effect is desired such as against personnel and barbed wire entanglements. The delay action is used against heavy targets and underground structures where penetration is desired to produce the most effective mining and concussion results.

Recently it was decided that each shell could be classified as for use against light targets or as for use against heavy targets. Thus, a single action fuze could be definitely assigned to each shell according to its tactical use. All of the light shell (7 pounds or less) were classified for use against light targets, as very little penetration could be obtained due to their light weight and blunt construction. It is also to be noted that the percentage of explosive filler as compared to the percentage of metal components (approx. 17 percent) was designed to destroy the light shell so as to produce efficient fragments which can be effective only if distributed above ground. The M52 P.D. Superquick Fuze was also assigned to the Chemical Shell M57, as it is necessary to function the chemical shell above the ground to obtain the proper effects and dispersion to its chemical filler. All the heavy shell of the H.E. type were classified for use against heavy targets and for use where a mining effect was necessary. It is also to be noted here that the percentage of explosive filler as compared to the percentage of metal components (approx. 40 percent) was designed to produce an efficient mining or concussion result with heavy shell which would be most effective if allowed to penetrate its target and then explode. The M53 P.D. Delay Action Fuze was assigned to these shell.

The M45 P.D. Selective Fuze was declared limited standard (S). It was a waste of one element to use a selective fuze on trench mortar shell, because it was known before the shell ever reached the firing point what action fuze was desired. The M52 P.D. superquick and the M53 P.D. delay are standard for issue and manufacture (S & M). It is interesting to note that the subdivision of a selective fuze into two separate fuzes is in definite opposition to the trend in artillery fuze design where the tendency is to combine two fuzes into one selective or combination fuze. This is true because in artillery fuzes the action desired varies with the condition at the field of battle.

Rounds used with these fuzes may be considered boresafe. The detonating elements are positively separated from the booster until the projectile has left the bore of the mortar. The fuzes are assembled to their respective shell and stacked in place. They are, therefore, being stored, shipped, and issued as a permanent part of the complete round. Each fuze is stamped with its model number, manufacturer's initials, and lot number for positive identification. The M45 can be obtained in a practice type. It has a black powder charge in place of a tetryl booster charge, and is designated as a point pr

**D-6e**



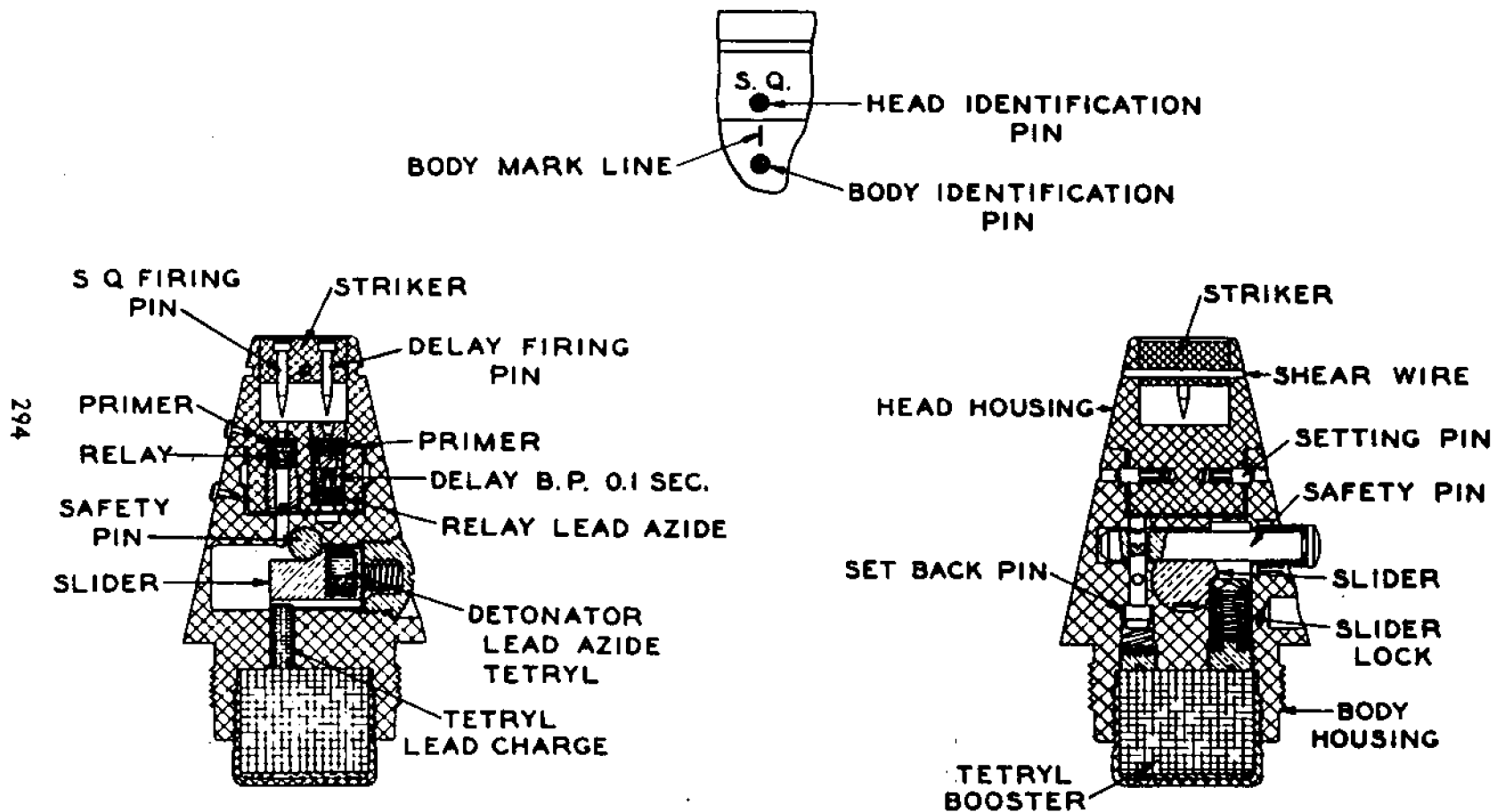

Figure 116 — FUZE, P.D., M45

RA PD 22904

## SMALL ARMS AND TRENCH WARFARE

fuze. The head is painted blue, and "Fuze, Point, M45, Practice" is stamped on the body.

### Point-detonating Fuze M45.

*Description.* The M45 Point-detonating Fuze is a selective, superquick, and delay action fuze, used to effect functioning of SHELL, H.E. M45, fired from the 81-mm trench mortar. This shell and fuze are now limited standard. The superquick setting is used when it is desired to obtain fragmentation of the shell above the ground, whereas the delay setting is used for underground action. The fuze weighs approximately 0.52 pounds.

The fuze housing is made of aluminum. The head of the fuze fits into the body so as to be able to turn on the body housing. The head houses a comparatively short, but wide, striker which is flush with the nose. The striker has two firing pins and is held in place by a shear wire. Underneath the firing pins is a superquick element and a delay element. One element is directly in line with a flash hole to the body explosive charges, and the other element is in line with a dead flash hole depending on the setting. Located in the head are setting pins and setting pin springs which when in proper position for either delay or superquick setting will engage recesses in the body. On the external surface of the head are stamped "S.Q.," or "D," to indicate the setting. The body houses the slider, slider lock, safety pin, and set-back pin, with their respective springs. In the center and at the base of the body is an inverted brass cup known as a lead cup. It is held in place by crimping, and contains a tetryl lead pellet. The base of the body is internally threaded to receive a booster cup, which in turn houses a tetryl booster pellet. On the external surface of the body is a marked line and an identification pin which indicates the setting.

*Setting.* When set for superquick action the head is set so that the "S.Q." stamped thereon is in line with the line on the body. Identification pins are provided for setting at night. These pins are so located that for superquick setting the heads of the pins are directly in line and for delay setting, they are 180 degrees removed. Pressure applied on the setting pin by the setting pin springs forces them to engage in recesses in the body at the exact position of "S.Q.," and "D" so as to restrain the head in proper position.

*Safety features.* The M45 Fuze is boresafe. This is accomplished by assembling the detonator into a slider which in the armed position holds the detonator out of alignment with the explosive train. Arming of the slider in the bore of the mortar is prevented by a safety pin, the head of which bears against the bore, thereby retaining the slider in the safe position. To prevent arming of the set-back pin, which holds the safety pin in position, a cotter pin is utilized, prevent

**D-6e**

## AMMUNITION INSPECTION GUIDE

the set-back pin from moving rearward against its spring during handling.

*Function when set for superquick action.* The cotter pin is removed, freeing the set-back pin. The shell is dropped down the bore of the weapon. The force of set-back resulting from ignition of the propelling charge causes the set-back pin to move down against the set-back pin spring, freeing the safety pin. The safety pin, due to the action of the safety pin spring, is forced out of the fuze until its head comes in contact with the bore of the mortar. After emerging from the mortar the safety pin is completely ejected by its spring from the fuze. The slider is now free, and due to the action of the slider spring is forced into the armed position, thereby bringing its detonator in direct alinement with the explosive train. The slider also serves to close the hole left by the safety pin, so as to prevent the entrance of mud or dirt into the slider cavity which might interfere with the fuze functioning. The slider is locked in the armed position by a slider lock which is forced up into a recess in the slider by a slider lock spring.

Upon impact with the target the striker is forced inward, breaking the shear wire and carrying both firing pins into their respective elements. The superquick firing pin ignites a primer which in turn ignites a lead azide relay charge. The lead azide relay detonates, and sends a wave to the detonator charge of lead azide and tetryl in the slider. The wave from the detonator functions the lead charge of tetryl. The wave from the lead charge of tetryl detonates the booster of tetryl which amplifies the wave and sends it to the shell filler. Simultaneously with the above action, the delay firing pin functions its primer. If the superquick action functions properly, the delay action will proceed no farther. If the superquick fails to function, the primer will ignite a black powder pellet which will burn for 0.1 second. The flame from the black powder delay pellet in turn will set off a relay of lead azide which will detonate and carry a wave into a blank flash hole where it will be stopped and will proceed no farther.

*Function on delay.* The head must be turned so that the "D" stamped thereon is in line with the mark line on the body. By means of setting the head as described, the delay element is brought into alinement with the flash hole and the superquick primer is 180 degrees removed. The fuze function is exactly the same until action on impact.

Upon impact the striker is forced inward, breaking the shear wire, carrying both firing pins into their respective elements. The superquick firing pin ignites its primer which in turn sets off a relay of lead azide. The wave produced passes into a blank flash hole and proceeds no farther. Simultaneously with the above action, the delay firing pin functions its primer. The flash from the primer ignites a

SMALL ARMS AND TRENCH WARFARE

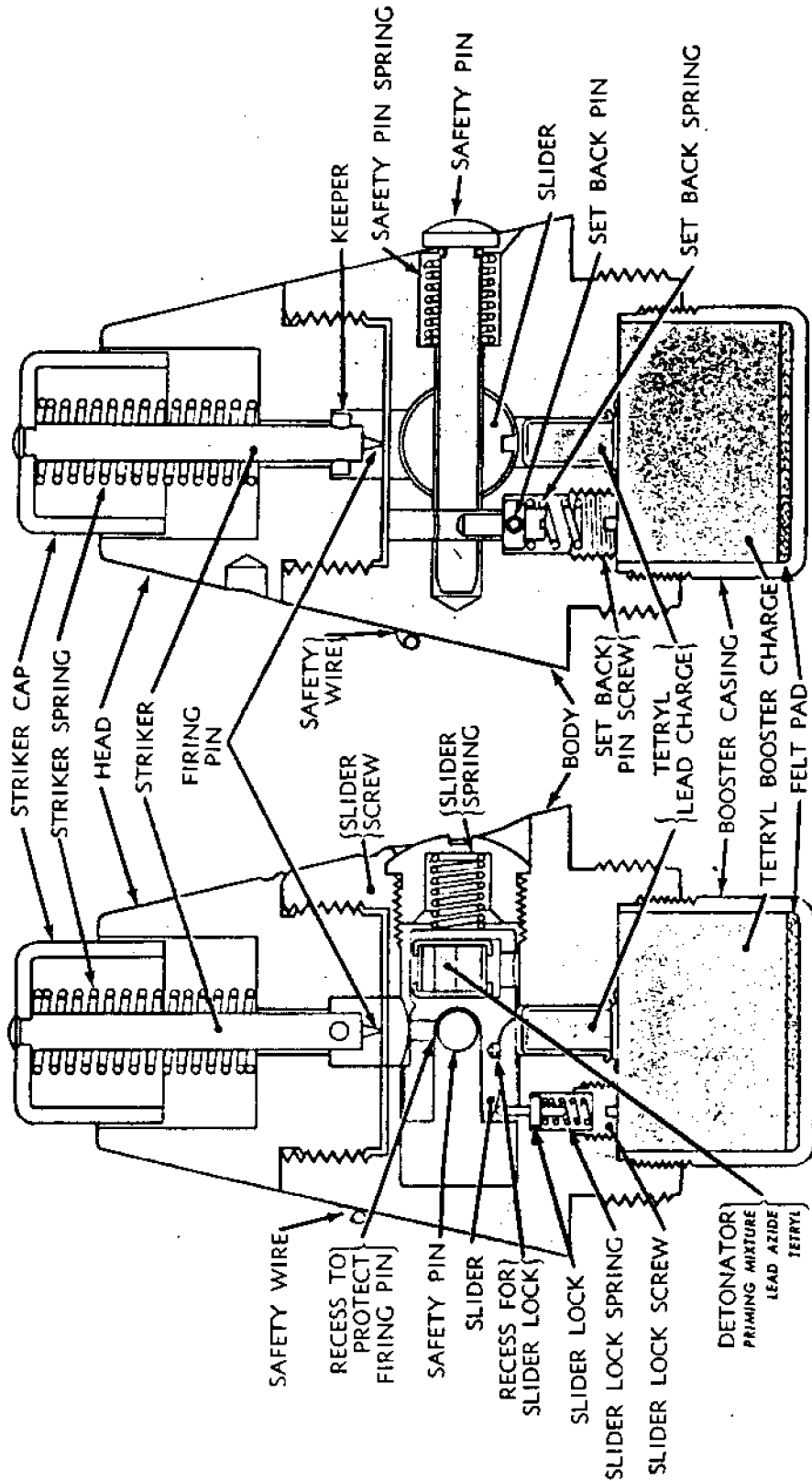

RA PD 22905

Figure 117 — FUZE, P.D., M52

## AMMUNITION INSPECTION GUIDE

black powder delay pellet which burns for 0.1 second. The delay pellet ignites a relay of lead azide which detonates, and in turn sets off the detonator charge of lead azide and tetryl located in the slider. The wave from the detonator functions the lead charge of tetryl which detonates, and functions the booster of tetryl. The booster charge amplifies the wave and sends it to the shell filler.

### Point-detonating Fuze M52.

*Description.* The M52 Fuze is a superquick fuze used to effect the functioning of rounds fired from the 81-mm and 60-mm mortars. It is normally used with light shell when fragmentation above the ground is desired. This fuze will fit any of the present "M" series of shell; however, it is only assembled in the following shell at present:

M43A1 H.E. for  
81-mm T.M.

M43A1 Practice for  
81-mm T.M.

M44 Practice for  
81-mm T.M.

M57 Chemical for  
81-mm T.M.

M49A2 H.E. for  
60-mm T.M.

M50A2 Practice for  
60-mm T.M.

The weight of the fuze is 0.45 pound.

The fuze housing is made of aluminum. The head of the fuze screws into the body. The head houses a long protruding striker and a compressed restraining spring. The striker and restraining spring are held in place by a keeper. The body houses the slider, slider lock, safety pin, and set-back pin, with their respective springs. In the center and at the base of the body is an inverted cup known as a lead cup. It is held in place by crimping and contains a tetryl lead pellet. The base of the body is internally threaded to receive a booster cup which in turn houses a tetryl booster pellet. The slider carries a detonator and a blank flash hole to receive and protect the firing pin from shocks due to handling and set-back action.

*Safety features.* The safety features correspond to the M45. The M52 Fuze is boresafe. This is accomplished by the assembling of the detonator into a slider which in the unarmed position holds the detonator out of alignment with the firing pin and the tetryl lead charge. Arming of the slider within the bore of the weapon is prevented by the safety pin, the head of which bears against the bore and retains the slider in the unarmed position. To prevent arming of the set-back pin, which holds the safety pin in position, a cotter pin (safety wire in later manufacture) is utilized.

*Function.* This fuze is armed in the same manner as the M45. The cotter pin or safety wire is removed to free the set-back pin. The shell is dropped down the bore of the weapon. The force of set-back resulting from ignition of the propelling charge causes the set-back pin to move rearward against its spring. This frees the safety pin.

SMALL ARMS AND TRENCH WARFARE

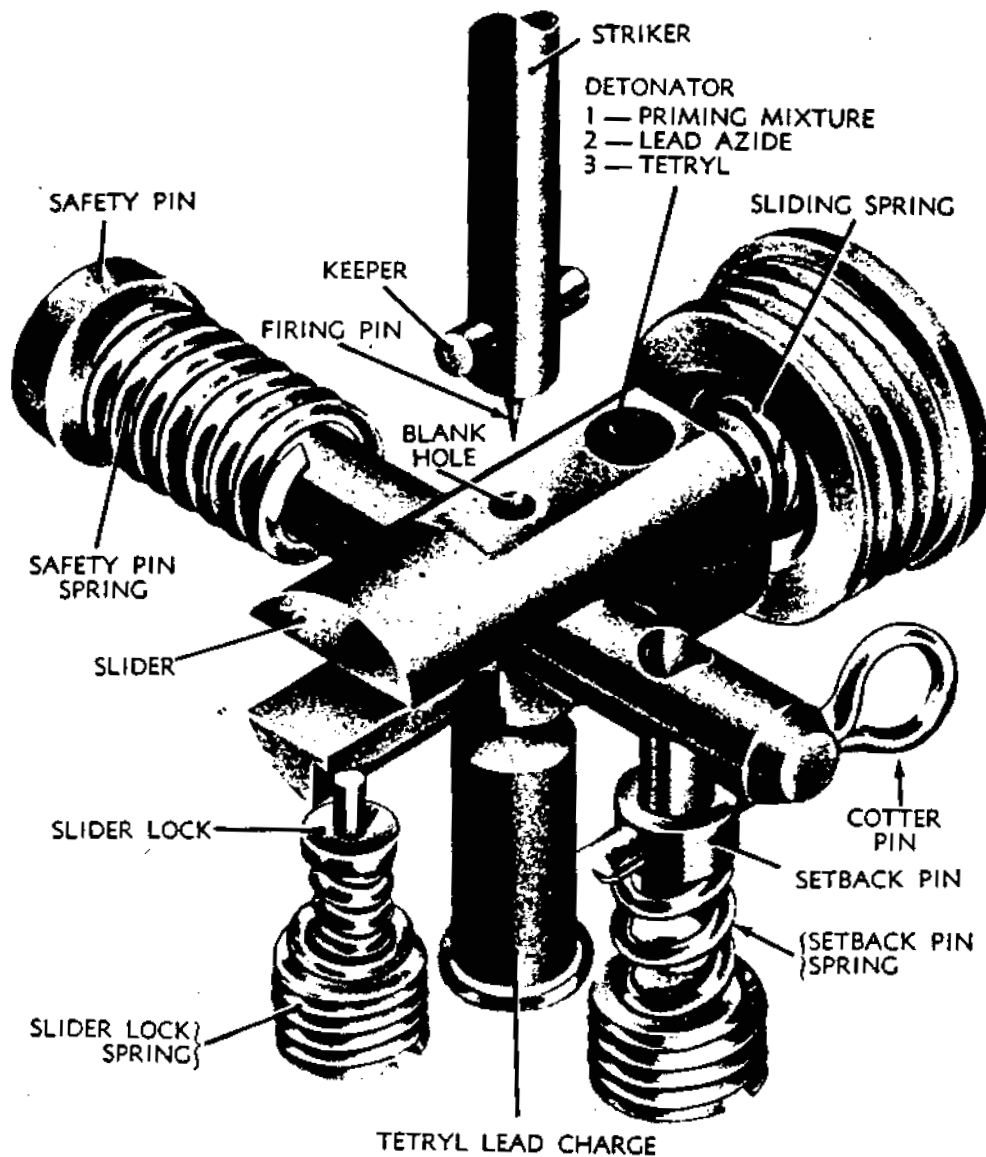

RA PD 22906

Figure 118 — Working Parts for FUZE, P.D., M52

The safety pin, due to the action of its spring, is forced out of the fuze until its head comes in contact with the bore of the mortar. After emerging from the mortar, the safety pin is completely ejected by its spring from the fuze. The slider is now free, and due to the action of the slider spring, is forced into the armed position, thereby bringing the detonator in direct alinement with the explosive train. The slider also serves to close the hole left by the safety pin, so as to prevent the entrance of mud or dirt into the slider cavity which might interfere with the fuze functioning. The slider is locked

D-6e

## AMMUNITION INSPECTION GUIDE

armed position by a slider lock which is forced into a recess in the slider by a slider lock spring.

Upon impact with the target, the striker is forced inward against its spring bringing the firing pin into the detonator charge of priming mixture, lead azide, and tetryl. The wave produced functions the lead charge of tetryl which in turn detonates the booster of tetryl. The booster charge amplifies the wave and sends it to the shell filler.

**Point-detonating Fuze M52B1.** This fuze differs from the M52 in that the body and head housing are made of bakelite instead of aluminum as the M52. In all other respects, it is identical to the M52 Fuze.

**Point-detonating Fuze M52B2.** This fuze differs from the M52 in that the body housing is made of bakelite, but the head housing is made of aluminum alloy. In all other respects, it is identical to the M52 Fuze.

**Point-detonating Fuze M53.**

*Description.* The M53 Fuze is a delay fuze used to effect the functioning of rounds fired from the 81-mm trench mortar. It is normally used with heavy shell where penetration is desired. This fuze will fit any of the "M" series of shell; however, it is only authorized to be assembled in the H.E. Shell M56 for 81-mm mortars. The weight of the fuze is 0.45 pound.

The fuze housing is made of aluminum. The head of the fuze screws into the fuze body. The head houses a comparatively short striker which is flush with the nose of the fuze. The striker is held in place by a shear wire. The head is internally threaded at the base to receive a delay assembly. The delay assembly houses a primer, delay pellet of black powder and a relay of lead azide. The body houses the slider, slider lock, safety pin, and set-back pin, with their respective springs. In the center and at the base of the body is an inverted brass cup known as a lead cup. It is held in place by crimping and contains a tetryl lead pellet. The base of the body is internally threaded to receive a booster cup which in turn houses a tetryl booster pellet.

*Safety features.* The safety features correspond to the M45 and M52 P.D. Fuzes previously described. The M53 is boresafe. This is accomplished by the assembling of the detonator into a slider which in the unarmed position holds the detonator out of alignment with the relay charge of lead azide and the lead charge of tetryl. Arming of the slider within the bore of the weapon is prevented by the safety pin, the head of which bears against the bore, thereby retaining the slider in the unarmed position. A set-back pin is used to hold the safety pin in position until set-back action occurs. To prevent arming of the set-back pin, a cotter pin (safety wire in later manufacture)

301

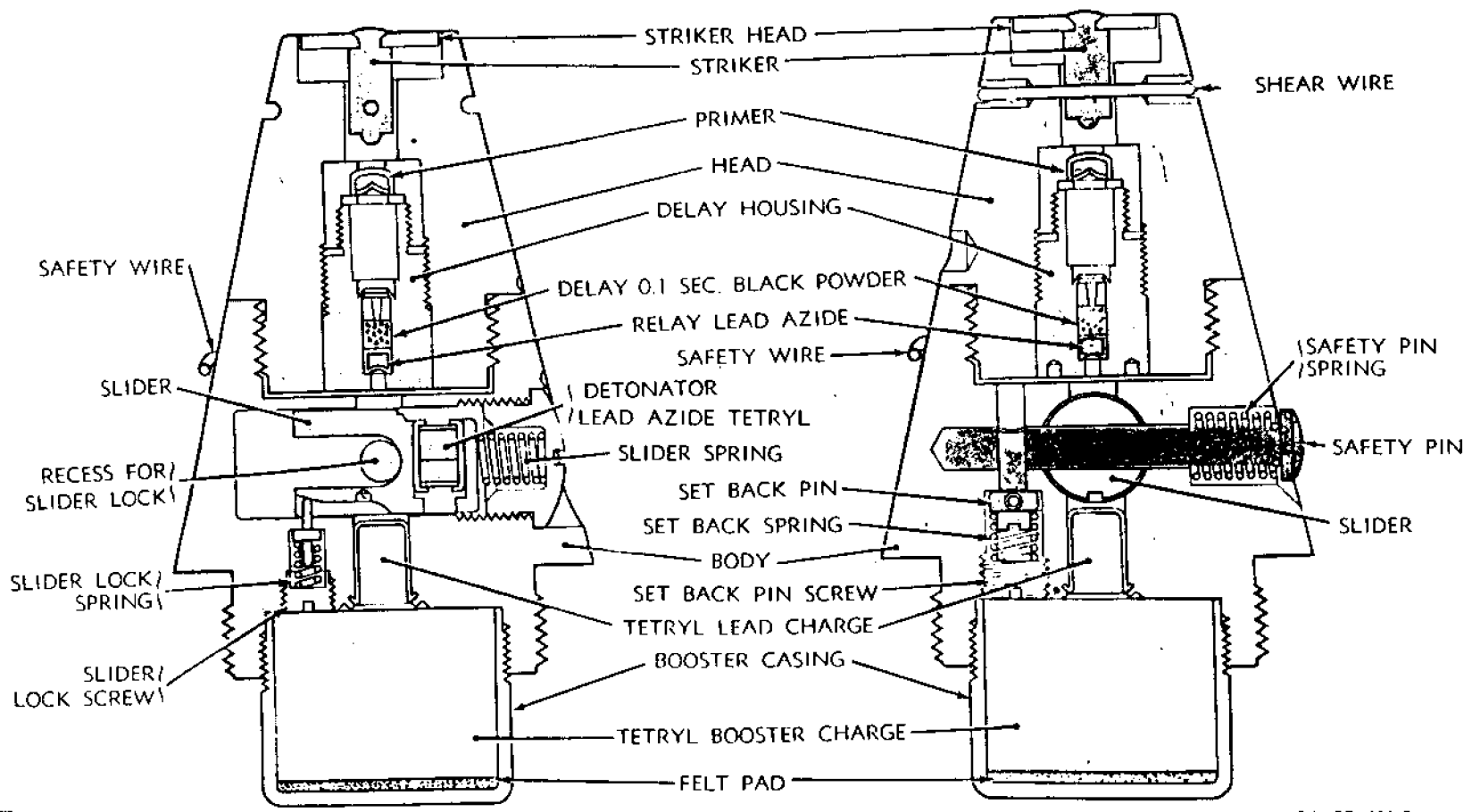

SMALL ARMS AND TRENCH WARFARE

TM 9-1904

RA PD 22907

Figure 119 — FUZE, P.D., M53

D-6e



**COMPLETE ROUND CHART FOR 81-MM TRENCH MORTAR WEAPONS**

Complete Round Designation	Filler	Fuze	Propellant Increment	Percussion Primer	Ignition Cartridge	Packing	Status
SHELL, H.E., M43	TNT	P.D. M45 or M52	400 grains (4 incr)	.....	M3	Fuzed	S
SHELL, H.E., M43A1	TNT	P.D. M52	700 grains (6 incr—M1)	M33	M6	Fuzed	S & M
SHELL, practice, M43A1	Inert Mat'l B.P. Pellet	P.D. M52	700 grains (6 incr—M1)	M33	M6	Fuzed	S & M
302 SHELL, practice, M44	Inert Mat'l B.P. Pellet	P.D. M52	700 grains (6 incr—M1)	M33	M6	Fuzed	S & M
SHELL, H.E., M45	TNT	P.D. M45 or M53	400 grains (4 incr)	.....	M3	Fuzed	S
SHELL, H.E., M56	TNT	P.D. M53	820 grains (4 incr—M2)	M34	M6	Fuzed	S & M
SHELL, chemical, M57	WP, FS, H	P.D. M52	820 grains (4 incr—M2)	M34	M6	Fuzed	S & M
SHELL, training, M68	.....	.....	.....	.....	M3	.....	S & M

**SMALL ARMS AND TRENCH WARFARE**

is utilized, preventing the set-back pin from moving rearward against its spring during handling.

*Function.* This fuze is armed in the same manner as the M45 and M52 P.D. Fuzes previously described. The cotter pin or safety wire is removed, freeing the set-back pin. The shell is dropped down the bore of the weapon. The force of set-back resulting from ignition of the propelling charge causes the set-back pin to move rearward against its spring, freeing the safety pin. The safety pin, due to the action of its spring, is forced out of the fuze until its head comes in contact with the bore of the mortar. After emerging from the mortar, the safety pin is completely ejected by its spring from the fuze. The slider is now free, and due to the action of the slider spring is forced into the armed position, thereby bringing the detonator in direct alignment with the explosive train. The slider also serves to close the hole left by the safety pin so as to prevent the entrance of mud or dirt into the slider cavity which might interfere with the fuze function. The slider is locked in the armed position by a slider lock which is forced up into a recess in the slider by a spring.

Upon impact with the target, the striker is forced inward against its shear wire, breaking it and bringing the firing pin of the striker into a primer. The flame from the primer ignites a black powder delay pellet which burns for 0.1 second. The pellet in turn ignites a relay of lead azide which detonates and in so doing sends a wave to the detonator of lead azide and tetryl. The detonator in turn functions the lead charge of tetryl which detonates the booster of tetryl. The booster charge amplifies the wave and sends it to the shell filler of TNT.

**General Information.** 81-mm ammunition can be used in 3-inch trench mortar weapons by making the following modifications:

1. The firing pin in the 3-inch trench mortar weapon must be lengthened. This modification will be found in the 3-inch Trench Mortar Mk. IA2. Therefore, the 81-mm mortar ammunition may be used only in the 3-inch Mk. IA2, and never in the 3-inch Trench Mortar Mk. I or Mk. IA1.

2. Maximum number of increments must be changed in the following manner:

Outer zone propelling charge must be reduced from six to four increments, for the M43A1 and M44 Shells.

Outer zone propelling charge must be reduced from four to three increments, for the M56 and M57 Shells.

The full charge of four increments may be used with the M45 shell.

The 3-inch trench mortar shell can be fired in an 81-mm weapon without any modifications being made.

AMMUNITION INSPECTION GUIDE



RA PD 22908

Figure 120 — SHELL, H.E., M49A2  
304

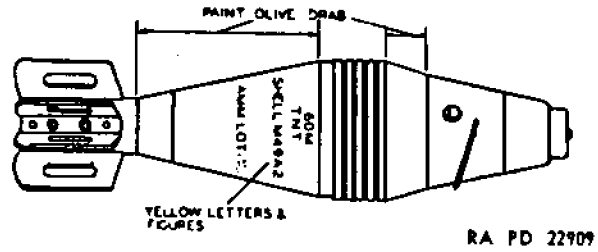
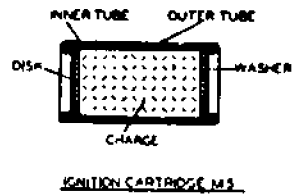
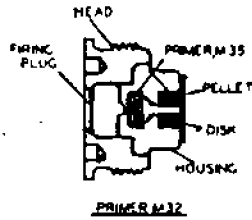
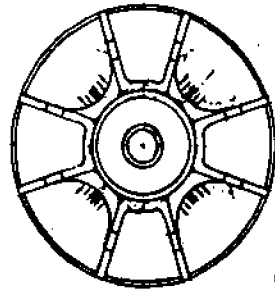
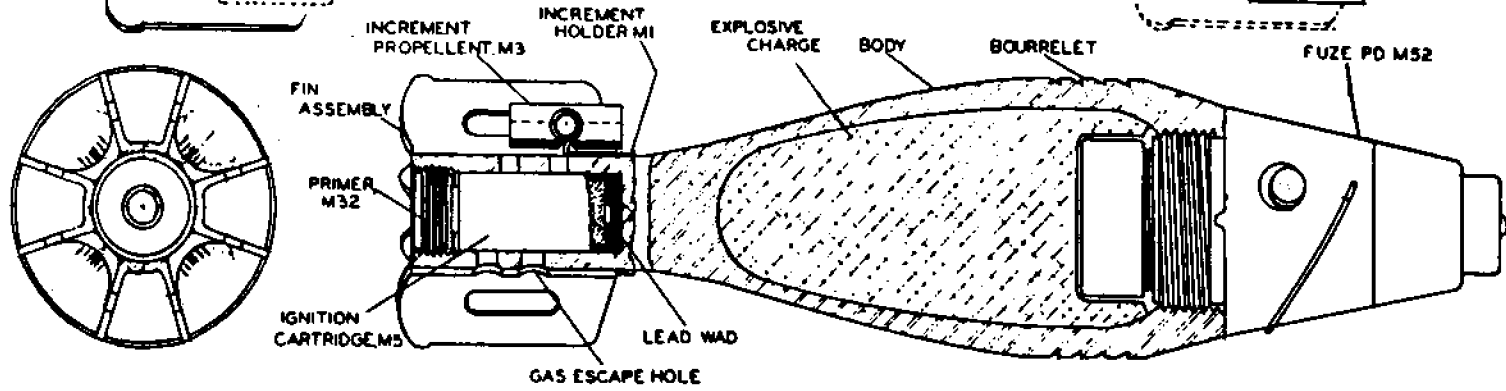
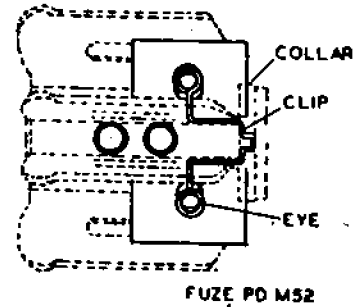
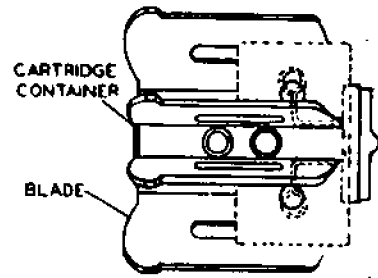

305

SMALL ARMS AND TRENCH WARFARE

TM 9-1904

Figure 121 — SHELL, H.E., M49A2

D-6e

## AMMUNITION INSPECTION GUIDE

## 60-MM TRENCH MORTAR.

**General.** For missions between ranges of usefulness of hand grenade and 81-mm trench mortar, the Ordnance Department initiated the development of a light 42-mm trench mortar.

Before a 42-mm trench mortar could be made, the Brandt Company furnished a 47-mm trench mortar which was suitable for infantry. The cavalry wanted something that had a greater maximum range than the 47-mm weapon. Consequently, a 60-mm trench mortar and ammunition for it was developed by the Brandt Company.

In 1938, the 60-mm trench mortar was adopted and the 47-mm trench mortar was rejected. The mobility of the weapon, due to its light weight, and the quantities of ammunition that can be carried, increased the fire power of the using arms in movement.

The general design of the 60-mm trench mortar shell is similar to the light shell for the 81-mm trench mortar. The method of firing is exactly the same. The color, marking, and stenciling are the same as for the 81-mm mortar ammunition of the same types. The class of ammunition used for the 60-mm mortar is once again semifixed. Four types of ammunition are at present provided for use in the 60-mm mortar: high-explosive shell, practice shell, training shell, and illuminating shell.

**SHELL, H.E., M49A2.** This is the present standard high-explosive shell for use in 60-mm trench mortar. It is used against light targets and personnel in the open.

*Shell body.* In shape, the body of this shell closely resembles the light shell for the 81-mm trench mortar; however, it is much smaller in size. Several methods of manufacturing the shell body are in practice at the present time, depending on the method best adapted to the individual manufacturer. The body may be of forged steel, cupped-rolled, plate-welded longitudinally, or a machined casting.

It is tear-dropped in shape, having a blunt nose and tapered tail. Near the nose end of the shell is a machined bourrelet which acts as a forward bearing surface and as a gas check. The nose is threaded to receive the fuze directly. The fuze used is the P.D. Fuze M52 which has a superquick action. Due to the light weight and blunt nose, very little penetration can be obtained. The shell is designed to produce fragments as the other light shells previously described. The tail end is closed and internally threaded to receive the stabilizer assembly. Earlier models of this shell had the stabilizer and body made from one piece with the fins attached. The shell filler is 0.34 pound of flake TNT. The weight of the round completely assembled is 2.94 pounds; the entire length of the shell with fuze attached is 9½ inches.

## SMALL ARMS AND TRENCH WARFARE

*The fin assembly.* The fin assembly consists of a machined cartridge container closed at one end with a threaded protrusion to screw into the shell body. It is hollow, with the other end threaded to receive an ignition cartridge and a percussion primer. A series of holes in the cartridge container serves to allow for the escape of gas, and to conduct the flame from the ignition cartridge to the propellant increments. Attached to the cartridge container are eight stationary fins in which may be seated the increments, or as recently changed, the increments are placed between the fins and held there by an increment holder.

*The ignition cartridge.* The ignition cartridge is the M5A1. It consists of a cardboard container having approximately 40 grains of double base powder. It supersedes the M5, and differs from it in that the number of grains of powder has been reduced from 47 to 40 grains. A hollow celluloid tube three-fourths inch long was also introduced at ignition end of cartridge. The M5 Ignition Cartridge produced erratic flight. Short ranges made it necessary for all members of the crew to be protected. With the M5A1, muzzle velocities have been reduced, but the maximum range obtained with all propellant increments and cartridges have not been reduced.

Previous to the M5 Ignition Cartridge, the M4 had been used. The M4 was a cardboard container having 47 grains of double base powder with a primer located in a brass base. It fitted snugly into the cartridge container and was disadvantageous in that set-back would cause residue of the M4 Ignition Cartridge to remain in the weapon.

*The percussion primer.* The Percussion Primer M32 is of the same construction and shape as the M33 previously described. It differs in that it has a narrow body diameter.

*The propellant increments.* The Propellant Increments M3 are made up of thin square sheets of double base powder sewn together. Each increment weighs approximately 35 grains. In the center of each increment is a hole which serves to increase the burning surface, and allows the increment to be held by the Propellant Increment Holder M1, by fitting into the wire loop of the increment holder. The corners, the sides, or edges may be notched to adjust the increment to the desired weight. The increments are held in place by seating in the fins diagonally, or recently by use of the Propellant Increment Holder M1. The Propellant Increment Holder M1 consists of a wire band seated around the stabilizer assembly near the body of the shell. Two thin wires bent in a V-shape, their ends in a circular loop, extend from the band down between the fins. On these loops are placed the increments by means of the holes in their center.

The percussion primer, ignition cartridge, and four increments comprise the full propelling charge; a total of 180 grains of powder.

## AMMUNITION INSPECTION GUIDE

*Zones of fire and range.* The shell has five zones of fire. The first zone of fire consists of the ignition cartridge and percussion primer. Zone five consists of the ignition cartridge, percussion primer, and four propellant increments.

Zone one has a range of approximately 100 yards.

Zone five has a range of approximately 1,935 yards.

*Marking and packing.* The shell body is painted olive drab with yellow stencil. The shell is shipped as a complete assembled round. One round is packed per individual fiber container, six individual fiber containers per large outer fiber container, three large outer containers (18 rounds) per bundle. One bundle per chocolate-stained wooden crate for overseas shipment.

**SHELL, Practice, M50A2.** SHELL, practice, M50A2, is similar to SHELL, H.E., M49A2. The shell body, components used, and packing are identical to the shell previously described. It differs in that its filler consists of 0.29 pound of inert material and 0.05 pound of a smoke producing pellet of black powder to act as a spotting charge. The body is painted blue with white stencil to indicate a practice shell.

**SHELL, Training, M69.** This shell is designed to give the mortar crew training in loading the weapon, and practice in firing under conditions which will not permit firing in more than the first zone.

*Shell body.* The body of the shell is cast iron. It is similar in shape to the 60-mm trench mortar shell and the M68 Training Shell for 81-mm mortar previously described. It is tear-dropped with a blunt nose and tapered tail. It has a bourrelet on the body near the nose to act as a forward bearing surface and gas check. At the tail end is a recess which is threaded to receive a stabilizer assembly. The nose end is closed and rounded with no provisions made to receive a fuze. Its weight varies depending on its weight zone. Seven weight zones are possible with a minimum of 3.83 pounds for weight zone one and a maximum of 4.07 pounds for weight zone seven without fin assembly and ignition cartridge.

*The fin assembly and propelling charge.* The fin assembly is of the same construction and shape as previously described. It receives the Ignition Cartridge M4. Several ignition cartridges are provided with each round so that the shell can be fired more than one time. There are no propellant increments used, for the shell is designed to be fired in the first zone only.

*Marking and packing.* The shell is painted black with white stencil. On the shell body will be found a number of white squares (one to seven) with a prick punch mark in the center of each to indicate the zone weight.

## SMALL ARMS AND TRENCH WARFARE

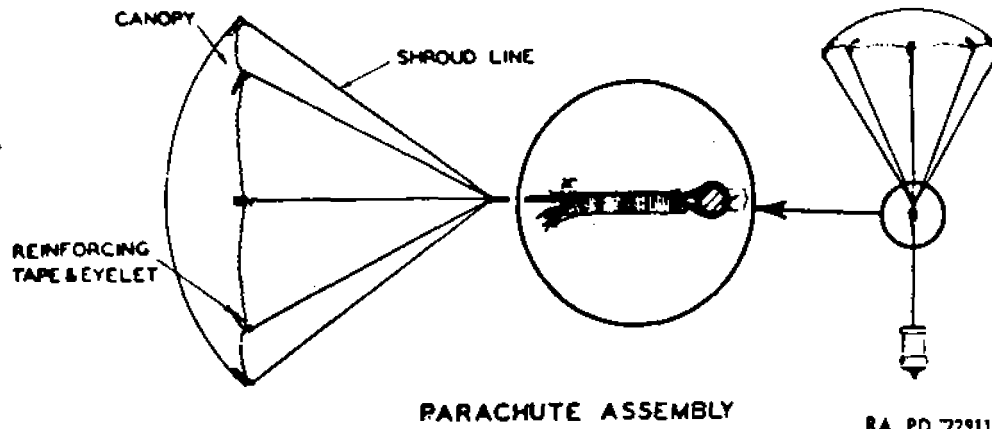

Figure 122a — SHELL, Illuminating, M83 — Parachute Assembly

Information as to the exact packing of the shell is not available at the present time. However, the complete round comes in separate units consisting of the shell body, ignition cartridge, and fin assembly.

**SHELL, Illuminating, 60-mm, M83.** The SHELL, illuminating, M83, was designed to provide a night light of relatively high candle power that could be fired from a standard infantry weapon. The SHELL, illuminating, M83, adequately fills the need, having 110,000 candle power, minimum, and burning for 25 seconds while drifting earthward on its parachute. The shell consists of the following components: fuze, body assembly, parachute assembly, illuminant assembly, fin assembly, propellant, and ignition cartridge.

*Shell body.* The body is constructed of a machined steel tube. It is cylindrical in shape with a tapered tail assembly and a nose assembly having its taper produced by the contour of the fuze. At the nose is a steel adapter spot welded and internally threaded so as to receive the Time Fuze M65. At the base of the cylindrical body is a coupling which serves to join the body to the tail assembly. The body is held to the coupling by means of four shear pins and Pettman cement. The tail assembly is held to the coupling by means of spot welding and Pettman cement.

The tail assembly consists of a cone to which is attached a fin adapter. The fin adapter is internally threaded to receive the fin assembly. The total weight of the shell completely assembled is approximately 3.8 pounds. Entire length of the fuzed shell is approximately 14.2 inches.

*Parachute assembly.* The parachute assembled in the illuminating shell is of sufficient size to permit the illuminant to burn 25 seconds while falling to the ground from a height of approximately 400 feet. The parachute assembly consists of a parachute canopy, tying eight eyelets, eight shroud lines, reinforcing tape, and tying three **D-6e**



## AMMUNITION INSPECTION GUIDE

The parachute canopy is cut from Fortisian cloth, in the form of an octagon, having a width of 36 inches and pinked on the periphery. The canopy has a porosity of 225 cubic feet air per minute per square foot.

At each corner of the octagonal canopy, an eyelet is crimped into the cloth, the latter being first reinforced by sewing on a strip of cotton tape with nylon thread.

One end of each of the shroud lines is tied to an eyelet. The cords in each assembly are the same length, usually 31 inches. The lines are tied together with tying cord, at a point 27 inches distant from the eyelets.

The shrouds are run through the flare assembly loop and tied firmly back upon themselves with tying thread. The canopy is then folded according to specified directions and inserted in the parachute case.

After the illuminant assembly is inserted in the body tube, the suspension wire (to which the shroud lines are attached) is coiled in the bottom of the parachute case. The two hemicylindrical steel parachute spacers are fitted into the rear end of the body tube. They fit snugly against the inner wall of the tube and rest on the steel disc of the flare assembly. The two spacers form the cylindrical parachute case into which the chute is placed. The chute and the suspension wire are separated in the case by an onionskin paper separator.

Two chipboard parachute discs are forced into place against the walls of the spacers. A coupling disc is placed on the runs of the parachute spacers and the tail assembly is pressed into position, and the shear pins are inserted.

*Illuminant assembly.* The illuminant assembly is the functional part, the "heart" of the shell, and is carefully designed to insure its effectiveness. The assembly fits into the shell body, and its front face is in contact with the fuze. Its rear face is attached to the parachute assembly by means of a suspension wire. The illuminant assembly consists of a case, first fire charge, illuminant charge, priming charge, suspension wire, steel disc, quick match disc, top disc, plywood plug, quick match, top seal, spacer, quick match spacer, tying string, reinforcing band, and binding tape.

The quick match is in contact with the expelling charge of the fuze. The quick match leads through four alined holes in the steel quick match disc, hair felt quick match spacer, and top disc. The ends of the quick match, which is in two lengths, are exposed to the fuze; the middles, after passing through the four holes pass thru the priming charge.

The priming charge consists of a 0.055-ounce pellet of Army black powder that is located just above and in contact with the first fire charge. The first fire charge is 0.74-ounce pellet consisting of a mixture of 25 percent black powder and 75 percent illuminant com-

- 1 CASE
- 2 FIRST FIRE CHARGE
- 3 ILLUMINANT CHARGE
- 4 PRIMING CHARGE
- 5 SUSPENSION WIRE
- 6 DISK
- 7 QUICK MATCH DISK
- 8 TOP DISK
- 9 PLUG
- 10 QUICK MATCH
- 11 TOP SEAL
- 12 SPACER
- 13 QUICK MATCH SPACER
- 14 TYING STRING
- 15 REINFORCING BAND
- 16 BINDING TAPE

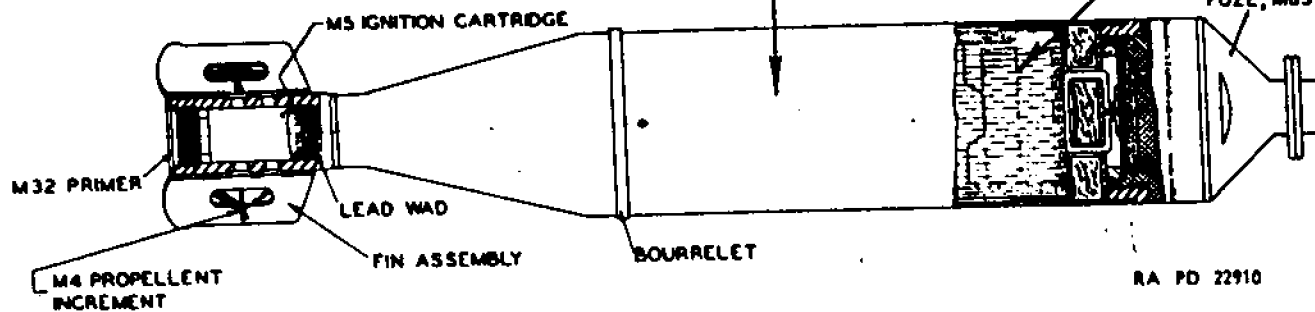
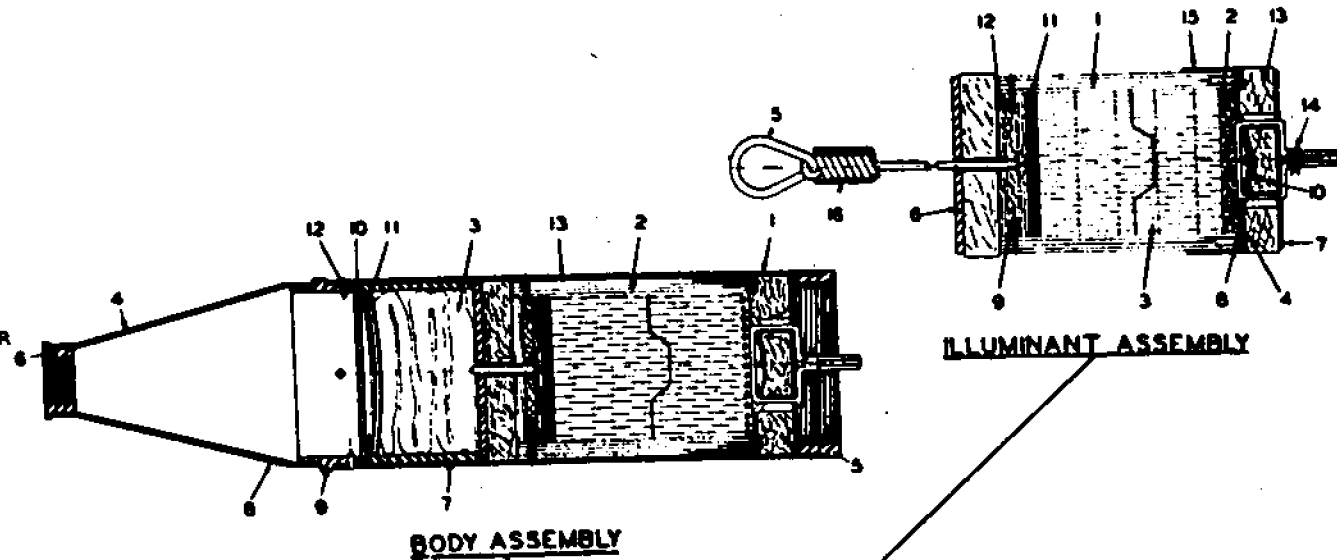

- 1 BODY TUBE ASSEMBLY
- 2 ILLUMINANT ASSEMBLY
- 3 PARACHUTE ASSEMBLY
- 4 TAIL ASSEMBLY
- 5 ADAPTER
- 6 FIN ADAPTER
- 7 PARACHUTE SPACER
- 8 CONE
- 9 COUPLING
- 10 COUPLING DISK
- 11 PARACHUTE DISK
- 12 SHEAR PIN
- 13 BODY TUBE

Figure 122b — SHELL, Illuminating, M83 — Body and Illuminant Assemblies

SMALL ARMS AND TRENCH WARFARE

TM 9-1904

## AMMUNITION INSPECTION GUIDE

position. Since the illuminant is difficult to ignite, the straight black powder priming charge and the partially black powder first fire charge are set up in series to insure ignition of the illuminant. The illuminant charge is just below the first fire charge and in contact with it.

The illuminant charge, which is pressed in two equal increments, weighs approximately 8.8 ounces, and has the following compositions:

	Percent
Barium nitrate .....	52.1
Sodium nitrate .....	10.4
Aluminum .....	26.0
Sodium oxalate .....	5.2
Sulfur .....	4.1
Castor oil .....	1.1
Linseed oil .....	1.1

The illuminant is ignited by the first fire composition and burns with a clear white light of 110,000 candle power, minimum, for 25 seconds minimum time. The illuminant (when the shell is in firing position) rests on a  $\frac{1}{8}$ -inch thick top seal of fire clay. Just below the fire clay is a  $\frac{3}{8}$ -inch thick plug of plywood, with a hole through its center.

All the components of the illuminant assembly mentioned previously with the exception of the quick match disc and a quick match spacer are within the illuminant case. The case is constructed of sheet box board  $\frac{3}{8}$  inch thick in the shape of a tube which will fit freely into the shell body. The quick match passes through four holes in the top disc. The disc serves as a cover for the case, after being glued and nailed into place. The fire clay top seal, illuminant, priming charge, and first fire charge are all shaped into discs to fit into the case. The quick match in passing through holes in the top disc and the quick match disc and spacer, anchors the latter two parts in place.

The suspension wire passes through the hole in the plywood plug, with the knotted end fitting flush in the pocket. The wire passes through aligned holes in the hair felt spacer and steel disc. The steel disc forms the rest for the parachute spacer in the parachute case. The suspension wire from the surface of this disc to the end of the loop is approximately  $11\frac{1}{2}$  inches long. The loop is formed by wrapping the wire about itself and then binding with tape. The complete illuminant assembly slips freely into the shell case coming to rest against the fuze.

The top disc closing one end of the case is further sealed by the addition of a strip of crinoline that is pasted over the sides of the case and top disc.

The hair felt spacers serve to protect the illuminant charge against the sudden shocks of set-back and expulsion from the body tube. They

**SMALL ARMS AND TRENCH WARFARE**

also assist in preventing the escape of expelling charge gases around the illuminant case.

*Fin assembly.* The fin assembly is the same as that assembled with the SHELL, H.E., M49A2.

*Ignition cartridge.* The ignition cartridge is the M5A1 previously described.

*Primer.* The primer is the M32 Percussion Primer previously described.

*Propellant increments.* The Propellant Increment M4 assembled with the illuminating shell are essentially the same as the Propellant Increment M3. The M4 Increments are composed of flake propellant powder, and each increment weighs 28 grains, which is less than the weight of the M3. Four increments are assembled with the illuminating shell, corners of the increments being wedged into the fin blade slots to hold them in place. An increment holder may be used with the illuminating shell to hold the propellant increments in place.

The percussion primer, ignition cartridge, and four increments comprise the full propelling charge; a total of 152 grains of powder.

*Zone of fire and range.* The shell is normally fired with the full complement of propellant increments. This fact and the fixed burning time of the fuze cause the shell to shear and the flare to commence to burn at a point at 800 yards range and 400 feet elevation. The parachute canopy controls the speed of descent so that the flare burns completely during its descent and no effect is lost by the flare burning on the ground.

*Action.* The cotter pin is removed from the fuze and the round is dropped down the bore of the mortar. The round is propelled from the mortar in the same manner as the H.E. shell, the propellant gases being confined by the bourrelet. Set-back causes the fuze to function in the manner described in pages 314 to 318. Ignition of the expelling charge in the fuze has two functions. First, to ignite the quick match; and second, to expel the flare assembly. The latter is accomplished by the expelling charge gases acting forcibly against the steel quick match disc. The shock caused by these gases is transmitted to the shear pins that hold the body tube to the tail assembling coupling. These pins are sheared and the flare assembly is expelled from the body tube. The tail assembly, the fuze, and the body tube fall free.

As the flare assembly (designation of the parachute assembly and the illuminant assembly together) is forced out of the case, the two parachute spacers fall free as do the coupling and parachute discs. The parachute spacers guide the ejection of the chute from the core, and when they fall free the parachute unfolds and checks the descent of the illuminant case. The flame from the expelling charge ignites the quick match, which in turn ignites the primer charge. As the qu

## AMMUNITION INSPECTION GUIDE

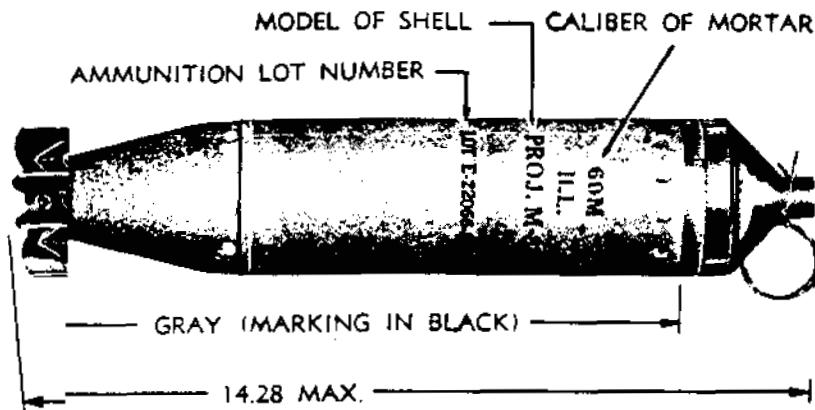

RA PD 2152

Fig. SHELL, Illuminating, M83 — Marking Diagram

through the holes in the quick match disc, and the quick match disintegrates, the two components fall free.

The charge ignites the first fire charge, and the latter ignites the illuminant charge. The burning of the illuminant ignites the shell but the case being in several thicknesses, burns at the shell as the illuminant and is able to support the charge for a long time. The fire clay prevents the flame of the shell from igniting the shroud lines, during the period of

packing. The shell body is painted gray with black markings. The shell is shipped as a complete assembled round. One shell per individual fiber container, six individual fiber containers per large outer fiber container, three large outer containers per bundle. One bundle per chocolate-stained wooden crate as shipment.

(Fixed) M65. The Time Fuze (Fixed) M65 is a simple powder fuze. It is a simple powder fuze whose burning time is fixed. The fuze consists of a fuze body, a time train ring assembly, a head assembly, and a fuze body.

The body is aluminum alloy die cast to the shape shown in figure 123. The upper projection is threaded to receive the primer. A recess is drilled to seat the primer. This recess narrows at right angles by a hole drilled through the walls of the body to form a recess. The continuation of the primer recess and the hole through the walls form the flash vent for the primer flame. The surface on which the time-train may rest is cut with eight longitudinal grooves. Glued to this grooved surface is a cloth washer. In the body, a recess is formed for the expelling charge. The end of this recess is threaded to receive the steel ex-

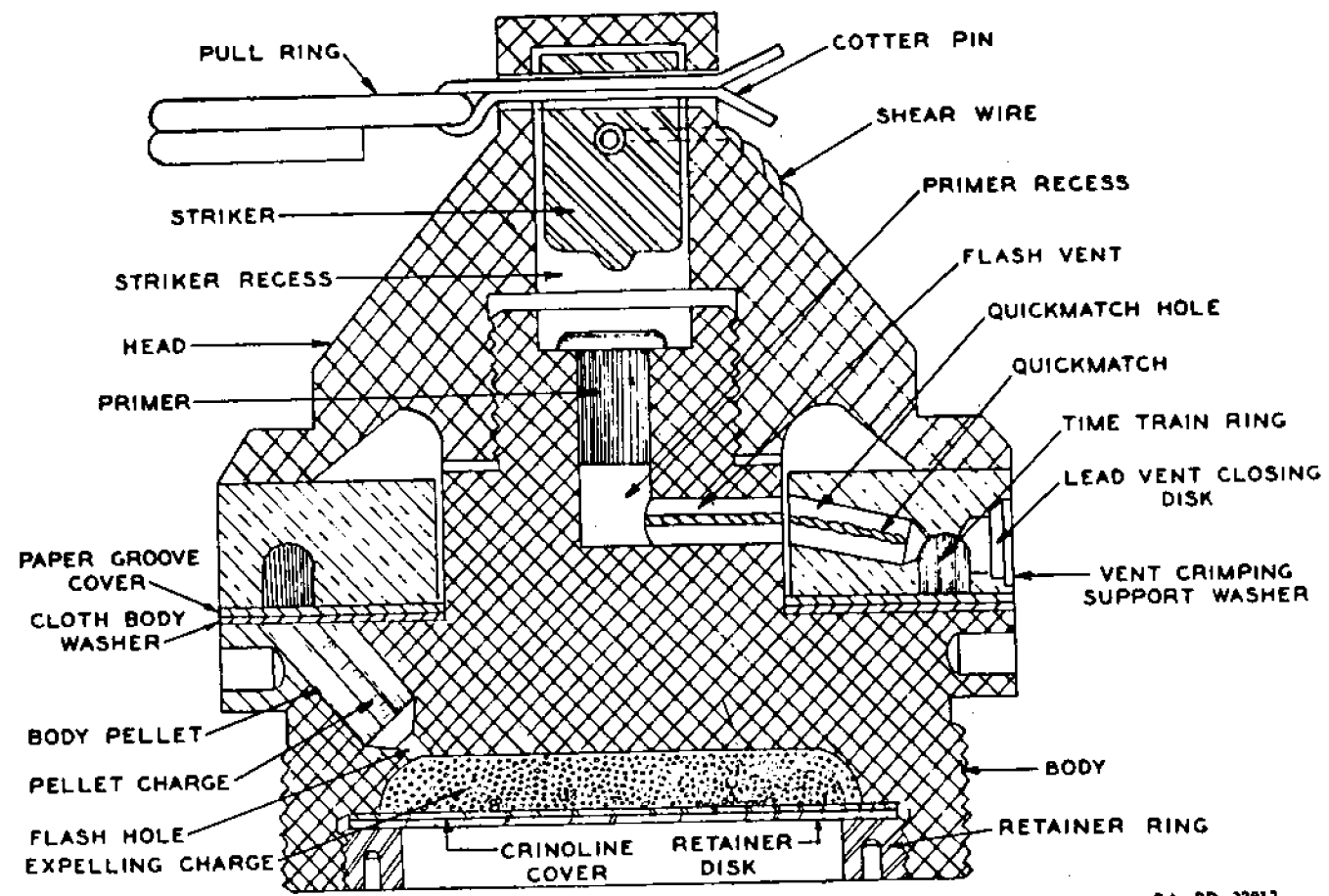

Figure 123 — FUZE, Time (Fixed), M65

RA PD 22912

## AMMUNITION INSPECTION GUIDE

PELLING charge retainer-ring that holds the steel expelling charge retainer-disc and crinoline against the expelling charge. Leading from the surface of the time-train ring recess base to the expelling charge recess is a hole. It is drilled at a 45-degree angle to the surface of the time-train ring recess base. The upper or larger section houses the body pellet; the lower section is empty, and is the flash hole proper. A final hole is drilled normal to the surface of the time-train ring base. In this hole is seated a brass locating pin that fits into a hole in the time-train ring, thus properly locating the ring in the final assembly.

*Time-train ring assembly.* The time-train is essentially a large thick washer that fits over the upper projection of the body and rests on the fuze cloth-covered surface of the time-train ring recess base. The time ring is made of brass. In the lower surface of the ring is an annular groove interrupted by a brass plug. The black powder time-train ring (groove charge) is housed in this groove. Leading into the groove from the inner wall of the ring is a hole. This hole is a continuation of the primer flash vent in the head and houses a length of quick match. Drilled from the outer wall of the ring and meeting the annular groove at the ignition of the quick match hole and similar groove hole is another hole. This hole is closed by a lead vent closing disc and vent crimping support washer. The disc melts on ignition of time-train charge and permits the combustion gases to escape. An onionskin paper groove cover is shellacked to the lower surface of the ring.

*Head assembly.* The head made of aluminum alloy has two functions: first, to house the striker; second, to hold the time-train ring securely in place. The striker is housed in a recess in the top of the head. Passing through the head and striker, is a removable cotter pin and pull ring. Also passing through the striker and head is a shear wire. The inner recess of the head is threaded to receive the projection on the body. An outer flange rests on top of the time-train ring, and, when the head is tightened, holds the ring firmly in place.

*Explosive components.* A primer which is the standard Mk. V Primer is used in this fuze. In the flash vent of the time-train ring is housed a 1/4-inch length of quick match that transmits the primer flame to the groove charge. The groove charge is approximately 60 grains of fuze powder, black powder of a very fine texture. It provides a time delay of approximately 14 seconds. The body pellet which leads from the ring to the expelling charge consists of approximately 5.2 grains of black pellet powder. The body pellet has a core, the pellet charge, which consists of approximately 0.02 grains of nitrocellulose. The expelling charge consists of 40 grains of black powder.

### COMPLETE ROUND CHART FOR 60-MM TRENCH MORTAR WEAPONS

Complete Round Designation	Filler	Fuze	Propellent Increment	Percussion Primer	Ignition Cartridge	Packing	Status
SHELL, H.E., M49A2	TNT	P.D. M52	140 grains (4 incr—M3)	M32	M5A1	Fuzed	S & M
SHELL, practice, M50A2	Inert Mat'l B.P. Pellet	P.D. M52	140 grains (4 incr—M3)	M32	M5A1	Fuzed	S & M
SHELL, training, M69	.....	.....	.....	.....	M4	.....	S & M
SHELL, illuminating, M83	Flare Composition	Time M65.	112 grains (4 incr—M4)	M32	M5A1.	Fuzed	S & M

317

SMALL ARMS AND TRENCH WARFARE

TM 9-1904

D-6e



**AMMUNITION INSPECTION GUIDE**

*Function.* The cotter pin is removed prior to dropping the round down the bore of the mortar. The shear wire retains the striker in its normal position. The sudden forward motion of the round being fired causes the striker, through set-back, to shear the wire and move to the rear. The firing pin of the striker functions the primer. The flame from the primer ignites the quick match in the time-train ring flash hole. The quick match in turn ignites the time-train ring groove charge. The groove charge has a burning time of about 14 seconds. When the flame from the groove charge has completed its circle about the time-train ring, it ignites the body pellet of black powder and the pellet charge of nitrocellulose. This, in turn, ignites the expelling charge. The flame from the expelling charge passes to the rear through apertures in the expelling charge retainer disc. The fixed burning time of the fuze permits the round, fired with full increment charge, to be nearly at its optimum range and height when the fuze has completed its function.

*Marking.* On the circumferential flange just above the body threads of the fuze is stamped in small characters: "Time fuze, M65."

*Packing.* The fuze is packed assembled to the round.

*Safety precautions.* The cotter pin must only be removed immediately before the round is placed in the mortar.

**FURTHER REFERENCES:** TM 9-1900, Ammunition in General; OS 9-18, Ammunition in General; The Ordnance Sergeant; TR 1350-3A, 3-inch Trench Mortar Ammunition; FM 23-90 Basic Field Manual, 81-mm Mortar M1; SNL R-4 Parts 1 and 2; Complete Round Chart No. 5981; O.O. 7224, Ordnance Safety Manual Elements of Ordnance, Hayes; Ordnance Drawings; Picatinny Text, Vol. III; Ammunition for 60-mm and 81-mm Mortars, Savanna Section, Ordnance School.

SIGNALS, SMOKE, GROUND: RED, M62; YELLOW, M64; GREEN, M65;  
VIOLET, M66

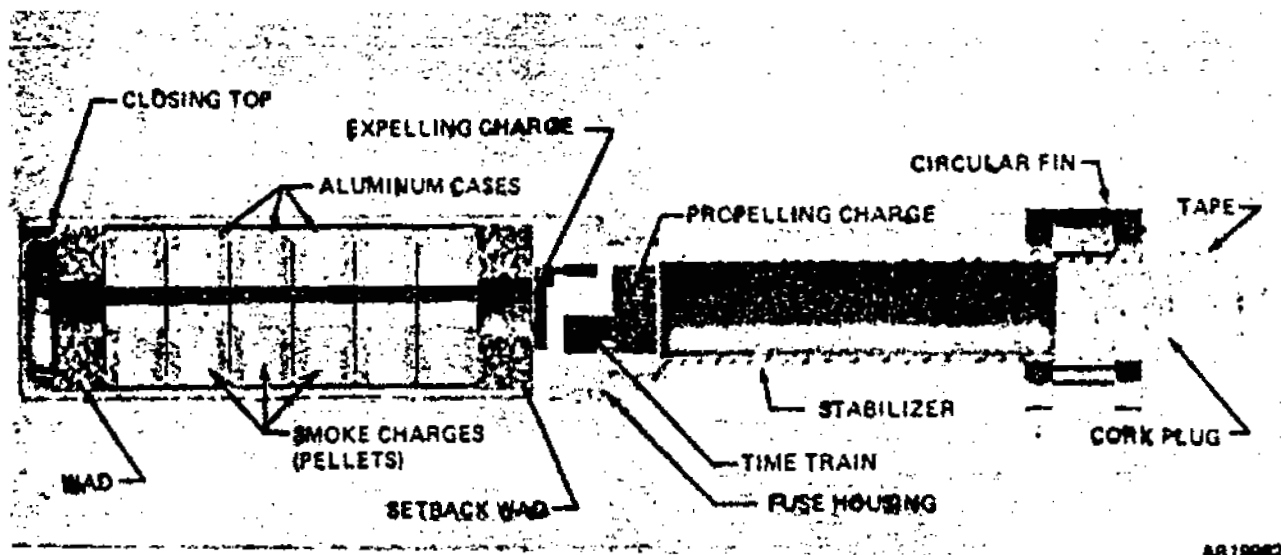
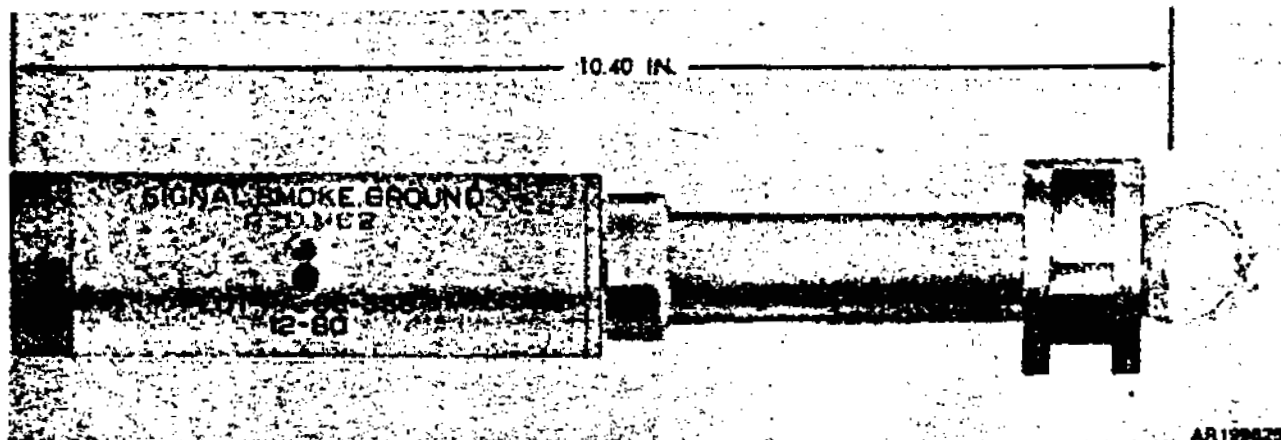

Type Classification:

- M62 -----Obs MSR 11756003
- M64 -----Obs MSR 11756003
- M65 -----Obs MSR 11756003
- M66 -----LSD OTCM 36841

Use:

For signalling during the daylight.

Description:

Each signal consists of an expelling charge and six smoke charges. The signal case, closed at the nose end with a steel closing top,

is a drawn aluminum body secured at the base to an aluminum fuse housing. The fuse housing has a circular time train groove filled with black powder and a smokeless powder propelling charge. A retaining disk holds the charge in place. A stabilizer, consisting of a hollow steel tube with a circular tail fin, is threaded to the fuse housing. The open end is closed, prior to firing, by a cork plug with a removal tape.

Functioning:

Flash from the M64 grenade launcher cartridge passes through the stabilizer to ignite the propelling charge, and the burning propellant ignites the 5.5 second delay train. Near the top of the trajectory, the time train initiates the expelling charge. The expelling charge

ejects and ignites the smoke charges out through the top of the case. As the charges descend tumbling from the trajectory height of approximately 600 feet, colored smoke streamers are emitted. The streamers will persist for about 20 seconds in a 5 MPH wind and may be seen up to 3 miles in clear weather.

Difference Among Models:

Color of smoke:  
 M62 ----- Red  
 M64 ----- Yellow  
 M65 ----- Green  
 M66 ----- Violet

Tabulated Data:

NSN's:  
 M62 ----- 1370-00-028-5999  
 M64 ----- 1370-00-028-6000  
 M65 ----- 1370-00-028-6001  
 M66 ----- 1370-00-028-6002  
 Weight loaded ----- 0.89 lb.  
 Length ----- 10.40 in.  
 Diameter ----- 1.88 in.  
 Method of actuation--- Fired from M76  
 grenade launcher  
 Body material ----- Aluminum  
 Color ----- Band with color  
 of smoke, markings in black  
 Pyrotechnic charge:  
 Type-M62 ----- Red composition  
 Type-M64 ----- Yellow composition  
 Type-M65 ----- Green composition  
 Type-M66 ----- Violet composition  
 Weight ----- 4.26 oz.  
 Propelling charge:  
 Type ----- Smokeless powder  
 Weight ----- 1.11 grams

*B-1*

Performance:  
 Delay ----- 5.5 sec.  
 Burning time  
 (smoke) ----- 4-8 sec.

\*Packing ----- 30 items per box

\*Packing Box:

Weight ----- 55 lbs.  
 Dimensions ----- 18-1/4 in. x 12-1/2  
 in. x 13-21/32 in.  
 Cube ----- 1.8 cu. ft.

\*NOTE: See SC 1340/98 IL for complete packing data including NSN's.

Shipping and Storage Data:

Quantity-distance  
 class ----- 2  
 Storage compatibility group ----- N  
 DOT shipping class--- EXPLOSIVE B  
 DOT designation--- SPECIAL FIREWORKS  
 HANDLE CAREFULLY  
 KEEP FIRE AWAY

DODAC:

M62 ----- 1370-L320  
 M64 ----- 1370-L322  
 M65 ----- 1370-L318  
 M66 ----- 1370-L321  
 Drawing number ----- 78-0-106

References:

AMCP 700-3-5  
 TM 9-1370-203-12  
 TM 9-1370-203-34  
 TM 9-1370-206-10

Not enclosed in this ASR

VESICANT AGENT PROTECTIVE OINTMENT: M5

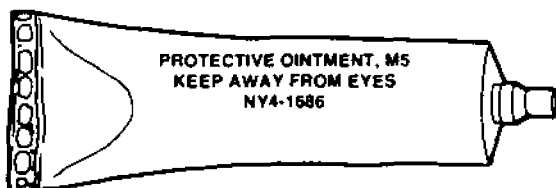

*Type Classification:*

Expendable; AMCTC 7124 69

*Use:*

To protect against or neutralize blister agents or V-type nerve agents before or after contamination of exposed skin on the body. It can also be used to protect and decontaminate personal equipment. It is used mainly for treatment of laboratory, storage, decontamination, and disposal specialists exposed to mustard.

*Description:*

M5 vesicant agent protective ointment is a white ointment containing chloramide S-330 as its active ingredient. The ointment is packaged in 3/4-ounce metal tubes, each approximately 3/4-inch in diameter and 3 3/4 inches long.

*Functioning:*

When M5 protective ointment is rubbed on the skin before exposure to blister agents or V-type nerve agents, it forms a protective coating that slows penetra-

tion by liquid chemical agents. When the ointment is applied to the skin or individual equipment after exposure to blister agents or V-type nerve agents, it serves as a decontaminant. It can also be used in an emergency to remove an unknown agent from the skin or individual equipment.

*Limitations:*

- a. M5 ointment does not neutralize G-type nerve agents.
- b. M5 ointment should never be applied to the eyes.

*Tabulated Data:*

NSN .....	6850-00-664-3647
Unit of issue .....	Tube
Basis of issue .....	CTA 50-970
Weight .....	0.6 lb
Length .....	3.75 in.
Diameter .....	0.75 in.

*Performance:*

Chemical reaction neutralizes H-type blister agents and V-type nerve agents by freeing chlorine released from chloramine S-330 in the ointment.

*Shipping and Storage Data:*

Type pack .....	144 per fiberboard box
Weight .....	15 lb
Cube .....	0.3 cu ft
Type storage .....	Warehouse
Drawing number .....	5-43-10

*References:*

- TM 3-220
- TM 3-250
- TM 8-285

ORDNANCE AND EXPLOSIVE WASTE  
ARCHIVES SEARCH REPORT  
FOR  
FORMER CAMP CROFT ARMY TRAINING FACILITY  
SPARTANBURG, SOUTH CAROLINA  
PROJECT NUMBER I04SC001603

APPENDIX E  
REPORTS/STUDIES

## APPENDIX E

### REPORTS/STUDIES

#### Table of Contents

---

- E-1 Pertinent Camp Croft Data, Originator Unknown, Undated,  
Source: Fort Jackson Museum
- E-2 POST WAR UTILIZATION STUDIES, Camp Croft, South Carolina,  
War Department, Office of the Chief of Engineers, September 1945
- E-3 Page 139, Listing of Military Locations, includes units  
within the Fourth Service Command, Originator unknown,  
Source: Fort Jackson Museum.
- E-4 Site Survey Report ERDA Project No IO4SC001600, Camp Croft,  
Spartanburg County, S.C., dated 1984.
- E-5 Camp Croft Landfill Sketch from the Camp Croft Landfill Site  
Screening Report, dated 30 March 1990.
- E-6 Generalized Geologic Map of Croft State Park  
Source: Dr. Terry A. Ferguson, Wofford State College,  
Spartanburg, S.C.
- E-7 Drawing (Sketch) of Croft State Park: Soapstone Quarry,  
Source: Croft State Park Management Plan, undated.
- E-8 Survey Open File Report No 64: Geologic Maps of the Pacolet  
and Pacolet Mills 7.5-Minute Quadrangles, South Carolina,  
by S. Mittwede, 1989.

CAMP CROFT, S. C.

1. Brief Historical Statement:

Camp Croft is an Infantry Replacement Training Center. It is named in honor of the late Chief of Infantry, Major General Edward Croft. Construction began 5 December 1940 and the first group of enlisted men arrived for training on 7 March 1941. The camp has trained infantrymen since that date without interruption.

2. Location:

Mail Address: Camp Croft, South Carolina

Nearest Town: Spartanburg, S. C., is approximately 5 miles from the post.

It has a population of 37,000 in the city proper, with 75,000 being in the metropolitan area.

Nearest Bodies of Water: Rainbow Lake (15 miles); Tiger River (12 miles); and Enoree River (25 Miles)

3. Size:

Total Reservation: <sup>19,034.86</sup> 21,706 acres, all government owned.

Presently used for buildings: Cantonment area of 2,668 acres. Includes 1,706 acres now used for training.

✗ Suitable for additional buildings or tents: 1,706 acres used for training in cantonment area is suitable for buildings or tents.

✗ Suitable for training, maneuvers: 1,706 acres in cantonment area (listed above)

4. Housing: <sup>10,342 acres in range impact area of which 743 acres are used for maneuvers and 6,267 acres are used for other training.</sup> <sup>448 acres outside both cantonment and impact areas.</sup> Accommodations for Officers 5526 acres additional maneuver area

BCQ, Cantonment type (Excluding WACs and Nurses)	755
BCQ, Cantonment type (WACs and Nurses)	96
Total	851

Accommodations for EM and EN

In cantonment type barracks	18,792	18 1/2
In T/O type barracks	128	omit
In COC type barracks	950	omit
(11000 barracks now used for BCQ, & used as officers)	Total	19,780
22 cottages used by EM and key civilians)		22 families.



a.	Type	Number	Capacity
a. <u>Officers</u>			
Bachelor	C	7 Qtr ( 1 each)	7
	C	17 Barracks ( 40 each)	680
	C	1 Barracks (20)	20
	C	2 Barracks ( 18 each)	36
	C	1 Barracks ( 12)	12
		Total (Not including Women) -----	755

b. <u>Women</u>			
Nurses	C	4 Bldgs ( 12, 18, 18, 24)	72
WACs	C	1 Bldg ( 24)	24
		Total	96

c. <u>Enlisted Men's Barracks</u>	C	290 Barracks ( 63 each)	18,270
	C	7, 8 Barracks ( 54 each)	452 378
	T/O	4 Barracks (32 each)	128
	CCC	19 Barracks ( 50 each)	950
		Total -----	19,848

( ~~Of CCC barracks listed, 11 now used to house PCW's, and 6 used as offices.~~  
Accommodations for 190 enlisted WACs included in above figures)

5. <u>Mess:</u>	Type *	Number	Capacity
a. <u>Officers</u>	C	1 (262) Medical Officers	262
	C	6 (118 each)	708
		Total -----	970
b. <u>Enlisted Men</u>	C	79	19,270
	T/O	1	100
	CCC	1	300
		Total -----	20,340
c. <del>Enlisted Patients (Hospital)</del>	C	1	<del>250</del>

\* Types--- C- Cantonment; T/O - Theater of Operations; CCC - Civilian Conservation Corps.

6. Transportation Facilities:

a. Bus Lines:

Name of Line-- Carolina Scenic Trailways

Terminals-- Buses run through camp and return to Spartanburg to connect with Carolina Scenic Trailways or Greyhound buses, or with trains going in all directions.

Schedule-- Bus enters camp every fifteen minutes during evening rush hours, every thirty minutes during day, and every hour during early morning.

b. Street Car Lines - NONE

c. Railroads

Steam-----Southern RR; Clinchfield RR; Piedmont and Northern RR; ; and Charleston and Western Carolina RR.

Electric -- NONE

Nearest Stations--

Passenger-- All lines, Spartanburg, S. C.

Freight---- Camp Croft- Delivered directly to camp by Columbia line of Southern R R. Switched on camp tracks by commercial engines of Southern R R.

Express---- Spartanburg, S. C. Delivered to post by Railway Express Company.

Trackage-

Single - Yes - 2.005 miles

Double \* NONE

Sidings- For 16 standard Pullman sleeping cars on post  
For 150 freight cars on post ( Siding tracks government owned)

Loading Facilities -

Accessible to trucks - 1/2 mile of track

Loading platforms----- 10

Ramp at end----- 1

Mobile R R Cranes----- NONE

Fixed Crane ----- NONE

Fixed Derrick \*----- NONE

Quartermaster truck crane-- 1

d. Highways Adjacent to or Entering Reservation

<u>Route No.</u>	<u>Surface</u>	<u>Width</u>	<u>Distance to Spartanburg, S. C.</u>
State Routes # 9 and # 276	Asphalt	30 ft	5 miles

e. Waterways--NONE

f. Airways

Landing Field: None on post. Navy and commercial air line share field 3 miles west of Spartanburg. Army has Air Base 28 miles west of Spartanburg near Greenville, S. C.

7. Utilities:

a. Post Telegraph Office: Western Union, Camp Croft, S. C.

b. Post Radio Station-- NONE

c. Electric Power

Plant or Transformer-- Substation with three transformers, maximum output to obtain 3-1000 KVA; 44,000 volts primary service; 6,900 volts primary distribution.

U. S. or Commercial-- Commercial

Capacity - K. V. A. 3-1000 (Maximum anticipated load 2,000 KW)

AC or DC---- AC

d. Gas--NONE

e. Sewage and Waste:

Sewage - Collected through branches into two outfall lines which deliver it to pumping station. Pumped through three and one half miles through 15-inch pipe to point where gravity carries it through 18-inch pipe to the disposal plant of the city of Spartanburg. Payment for a minimum of 2,000,000 gallons daily is guaranteed the City of Spartanburg.

Garbage and Rubbish Disposal-- Post incinerator burns about twelve tons of garbage daily. Between two and three tons of waste paper are ~~now~~ salvaged, bundled, and sold daily. Post dump receives matter neither combustible nor salvageable.

f. Water Supply

Source -- City of Spartanburg which gets water from a lake receiving 28 million gallons daily in lowest period.

Daily capacity-- 6,000,000 gallons. (Camp guarantees use of 1,500,000 gallons daily)

Storage capacity-- 2,230,000 gallons gravity tank (filtered water)

Treatment - Chlorination and addition of silica of soda

g. Fire Department

Number of men - 31 civilian firemen, including fire chief. In addition, 13 enlisted men are on duty in fire stations each night and on call during the day.

Apparatus-- 2 pumpers, 750 gallons per minute  
5 pumpers, 500 gallons per minute

Hydrants-- 170

Rose-- 15,000 feet, 2 1/2 inches diameter  
1,350 feet, 1 " "

8. Storage Facilities

a. Warehouses

Type	Number	Total Capacity	
		Sq Ft	Cu Ft
Receiving, Stationery, Supplies (QM)	1	9190	91,900
Storage and Bedding (QM)	1	9190	91,900
Classification (QM)	1	9190	91,900
Clothing (IRTC)	2	18380	183,800
Stove Parts (QM)	1	9190	91,900
Commissary storage (QM) (Stove in other half)	2 1/2	22975	229,750
Ordnance	3	24880	513,800
Ordnance and Signal	1	6894	68,940
Painter	2	18380	183,800
Painter (Paint)	1	800	8,000
Ordnance, CWS, and CWS Repair	1	6500	130,000
Post Exchange	1	3500	35,000

16 2/3

139069 - 1520

1,309 - 13

**E-1**

*Oil Storage (Ordn)*

3  
174

140270 1522730

9. Firing Ranges

<u>Type</u>	<u>Dist from Eq.</u>	<u>No. of targets</u>	<u>Other data</u>	<u>Direction</u>	<u>Back-stop</u>
<u>Rifles</u>				Range area between 140 to 210 degrees	Natural terrain for all ranges
BAR	3 Miles	20 targets	1000 inch range		
BAR & Carbine	3 "	50 "	200-500 yards		
BAR, Cal.30 MI and Carbine	3 "2	200 "	200, 500 500 yards		
BAR	1½ "	16 Points	Field Firing		
Rifle and Machine Gun	1½ "	12 "	Technique of Fire		
Cal.30 MI	1½ "	8 "	Technique of Fire		
Cal.30 MI	1½ "	8 Sets	Landscape Firing		
Cal.30 MI	1½ "	20 Points	Field Firing Two Groups		
BAR & LMG	2 "	10 Lanes	Field and Transition Firing		
Cal.30 MI	1½ "	2 sets	Landscape Firing		
Cal.30 MI	3 "	24 Points	3 Groups, 8 each Transition Firing		
Cal .30 MI and BAR	1½ "	8 points	Field Firing		
Cal.30, AAF	2 "	22 "	16 Points Tracking 6 Points Firing		

b. Machine Gun

Sub MG and Shotgun	1½ Miles	2 Points	Regulation Targets		
LMG & HMG	2 "	100 Targets	1000 inch Range		
LMG & HMG	2 "	4 Points	Field Firing		
LMG, HMG, and Cal.50 MG	2 "	8 Points	Moving Ground Targets		
LMG	2½ "	8 "	Field Firing		

9. Firing Ranges (continued)

<u>Type</u>	<u>Dist from Eq</u>	<u>No. of targets</u>	<u>Other Data</u>	<u>Direction</u>	<u>Backstop</u>
c. <u>Mortar, Grenade &amp; Rocket</u>				Range area between 140 to 210 degrees	Natural terrain on all ranges
Rocket Launcher	2 Miles	16 Points	8 Live 8 Practice		
AT Grenade	2 Miles	12 Points	4 Live 8 Practice		
60 MM & 81 MM Mortar	2½ Miles	8 Points			
60 MM Mortar & MF	2½ Miles	4 Points	Field Firing		

d. Pistol and Revolver

1½ Miles      20 targets      Regulation Range

- e. Other Training Aids --
- 2 Gas Chambers
  - 1 Gas Obstacle Course
  - 12 Obstacle Courses
  - 1 Infiltration Course
  - 9 Fit-to-Fight Courses
  - 1 Village ( Jap )

	Number	Total Capacity	
		Sq Ft	Cu Ft
b. <u>Sheds</u>	6	38,535	462,420
c. <u>Magazines</u>			
C. W. S.	1	961	8,841
Ordinance	9 Portable igloos (Steel)	7,000	56,000
Ordinance	5 Bldgs	880	12,720
	3 Sheds	200	3,000

d. Cold Storage-- 1 storage plant for perishables. 2 storage plants for ice.

9. (Attached sheets)

10. Service Facilities and Installations

a. Bakery-- Capacity 8,273 pounds daily

b. Commissary and sales-- One store for groceries, staples, meats, and other items.

c. Exchange - operates:

Main store - selling clothing, accessories, tobacco products, periodicals, candy, drugs and sundries, insignia; equipped with soda fountain; equipped with indoor and outdoor beer garden.

6 Branch stores - all selling complete line of authorized merchandise; all have soda fountains; all equipped for sale of beer.  
(One of these is located in hospital proper)

4 Beer gardens - selling beer, soft drinks, ice cream, cookies, peanuts.

2 Cafeterias - selling meals and short orders.

Service Station - sells gasoline and oil; services cars.

9 Barber Shops

1 Beauty Shop

Bowling Alleys, Pool Tables, and small canteen in basement of Field House.

Cleaning and Laundry Shop)

Photographic Studio)

Amusement machines)

Through Concessions

- d. Laundry-- 1 Type 4. Handles approximately 1,000,000 pieces monthly. Has produced yearly profit of approximately \$75,000. Has operated for past three months at 107 per cent effectiveness according to OQMG standards.
- e. Repair Shops -- Motor Pool - 1st and 2nd Echelon  
 Ordnance Machine and Armament Shops  
 Motor Repair Shops- 4th Echelon  
 Clothing and Equipage  
 Upholstery  
 Electrical  
 Carpenter  
 Sheet Metal  
 Refrigerator  
 Heavy Equipment  
 Blacksmith  
*Plumbing PAINT*
- f. Hostess House - 1 with capacity of 30 persons
- g. Service Clubs - 1, equipped with Cafeteria (Operated by Exchange) and large dance floor.

<u>Libraries - 2</u>	<u>Capacity</u>	<u>On Hand</u>
Newspapers	70	43
Magazines	142	217
Books	9,000	8,925

- i. Chapels - 6. All cantonment type, capacity 400, <sup>EACH</sup> all equipped with Hammond electric organ.

- j. Station Hospital - Capacity 801 beds. Emergency capacity 819.

- k. Nearby Civilian Hospitals \*

<u>Name</u>	<u>Location</u>	<u>Distance</u>	<u>Capacity</u>
Spartanburg General Hospital	Spartanburg, S. C.	8 mi	293 beds and 57 bassinets
Mary Black Cline	" "	5 min	62 beds

## 11. Recreational Facilities

- a. Movie Theaters - 4 with ~~each~~ capacities of 1,014; 1,008; 1,008; and 354 respectively.
- b. Amphitheater - 1 with seating capacity of 2,100.
- c. YMCA - in Spartanburg
- d. Sports -

Tennis -- 5 courts

Baseball - 8 ball fields

Softball \* 2 ball fields

Gymnasium - in Field House

Basketball - 2 regulation courts in Field House

Swimming - 3 large pools on post

Shuffleboard - 4 courts

Badminton - 4 courts

Boxing - 4 <sup>AREAS</sup> in regimental areas; ring can be erected in Field House and in Amphitheater.

Volleyball - 55 courts.

e. Other Facilities

Bowling, theater group, orchestras, dances, concerts, all types of indoor games, language classes, dancing classes, USO shows, Variety shows, radio programs (local commercial station), voice recording, GI Movie Weekly, one "Big Name" band monthly for dance, Camp Newspaper (The Spartan).

12. Climate

Spring - mild ~~and~~

Summer - hot

Autumn - mild

Winter - cool ~~and~~

*Average Annual Temperature - 60.5 Degrees. Average Annual Rainfall - 48 inches*

13. Clothing - Cotton during late spring, summer, and early autumn; woollens during the remainder of the year.



FOURTH SERVICE COMMAND

CROFT, CAMP (II) ✓  
(Spartanburg, South Carolina)  
(PO Camp Croft, South Carolina)

Band (Inf RTC #1) (AGF)  
Band (Inf RTC #2) (AGF)  
\*Band (Inf RTC #3) (AGF)  
Infantry Replacement Training Center (AGF)  
Infantry Officer Replacement Pool  
Officer Pool School  
Officer Candidate Preparatory School  
Reclassification Pool  
6th Inf Tng Regt  
32nd through 35th Inf Tng Bns  
7th Inf Tng Regt  
36th through 39th Inf Tng Bns  
8th Inf Tng Regt  
26th & 27th Inf Tng Bns  
9th Inf Tng Regt  
28th through 31st Inf Tng Bns  
\*10th Inf Tng Regt  
49th & 50th Inf Tng Bns  
40th Inf Tng Bn  
Spec Tng Units  
Ordnance Service Command Shop (ASF)  
Post Photographic Laboratory (ASF)  
71st Repl Bn (AGF)  
319th Sta Hosp (150-bed) (ASF)  
1405th SCU: Armed Forces Induction Station (ASF)  
1454th SCU: Station Complement (ASF)

CROSLAND AIRPORT ✓  
(Bennettville, South Carolina)  
(see Bennettville Municipal Airport, South Carolina)

CROSS CITY ARMY AIR FIELD (III) ✓  
(Sub Base of Orlando Army Air Base, Florida)  
(Cross City, Florida)  
(AAF)

4th Airways Com Sq, Regional--Det  
42nd Base Hq & Air Base Sq--Det  
305th Fighter Sq

CROSSVILLE INTERNMENT CAMP (I) ✓  
(Crossville, Tennessee)  
(ASF)

301st MP Esc Gd Co--Det (ASF)  
316th MP Esc Gd Co (ASF)  
318th MP Esc Gd Co (ASF)  
1478th SCU: Crossville Internment Camp (ASF)

CUNNINGHAM FIELD (III) ✓  
(Marine Corps Base)  
(Cherry Point, North Carolina)  
(AAF)

AAF Weather Station (Type C)

SITE SURVEY REPORT

CAMP CROFT

SPARTANBURG COUNTY, S.C.

1. Determination of DOD Responsibility. An on-site visit to the former Camp Croft Army training center was made by Stephen Morrison (SACEN-E), Norman McGee (SASRE-M) and Rick Thomas (Fort Stewart, Savannah, Ga.) on 12 August 1984. In 1946, the 19,044.46 acres that had made up Camp Croft were disposed of by DOD: some to former owners, some to the State of South Carolina for a park, and some to a Spartanburg County Foundation, which resold it for private industry, residential housing, recreation, and other uses. Further investigations to delineate the many current owners of former Camp Croft property were conducted by Mr. McGee. Mr. Morrison questioned several of the private land owners, the Spartanburg County Sheriff, the Civil Defense Department, the Fort Jackson 48th Explosive Ordinance Disposal Unit, the Croft Fire Department, the South Carolina Department of Health & Environmental Control, and representatives of the Spartanburg County Foundation. Croft State Park Superintendent, Ray Hayes, explained the acquisition of the State Park's 7,000 acres, its current use, and a great deal about property outside the park boundaries. Mr. Hayes drove us around the State Park property and over much of the privately owned land that had made up Camp Croft. His cooperativeness, 14 years service at the park, and general knowledge of the area make him the best local POC for future actions.

a. Building Demolition and Debris Removal. Mr. Hayes knew of no structures or debris left by the Army inside the park that were considered hazardous or unsightly. Some Army structures had been converted to picnic shelters or storage buildings; other bunker-like structures were being used by Boy Scouts, the Army, and others. Outside the park, buildings which were not demolished prior to disposition of the property were converted to a variety of uses, such as apartments, businesses, or

\* P2. The U.S. acquired the land in fee/lease/etc. by instrument.  
 P3. The Army used the site as a  
 P4. Kind was assessed & disposed as follows? Residual?

-1-

10 PM  
 U.S. ARMY ENGINEER DISTRICT, CHARLESTON  
 CORPS OF ENGINEERS  
 P.O. BOX 919

CHARLESTON, SOUTH CAROLINA 29402-0919

OFFICIAL BUSINESS

E-4

storage. Of the many persons questioned, none knew of debris or structures of a hazardous or unsightly nature that would qualify for ERDA removal: No debris removal or demolition is recommended for FY 84, and it is unlikely that future investigation will uncover other problems of this nature.

- b. Hazardous and Toxic Waste Disposal. No one in the Sheriff's Office, Civil Defense Department, Fire Department, or SCDHEC was aware of any hazardous or toxic wastes on former Camp Croft lands or unexplained contamination of surface or ground waters that might be traced to former DOD use. None of the current land owners that were contacted or the State Park Superintendent knew of any such problems. There is a possibility that somewhere on the 19,000 acres of Camp Croft property, wastes were buried which may cause problems in the future. Mr. John E. Gosset, Sr., of Spartanburg assisted in the dismantling or demolition of Camp Croft property and materials at the end of WW II. He had heard of other details working on similar tasks which put drums and other materials in wells which were then closed. He did not see this done and knew nothing about the contents of the fill used. Mr. Cunningham, a trustee of the Spartanburg County Foundation, made reference to a dump site, now on either the State Park or Hivann Company property. He did not know the nature or extent of DOD use of the dump site, but said that civilian persons had used and may still be using it. See Section 2, Project Scope.

- Was there a requirement that the area be fenced?*
- c. Ordnance and Explosive Waste Removal. Within the State Park boundaries, 44 acres were restricted in a quit-claim deed to "surface use only" because of its previous use "as an impact area of artillery, mortar, grenade, rifle, machine gun, and bazooka ranges", and the potential for "unexploded and dangerous bombs, shells, rockets, mines, and charges either upon or below the surface". Mr Hayes said that a group of Boy Scouts had uncovered two boxes of 30 cal. ammunition, which presumably had

been buried prior to transfer of the property to the State. He also told of finding "several" hand grenades scattered about a wooded area near an old foundation. He did not know if the grenades were "live" or deactivated training devices. On 12 August 1984, we returned to the site but were unable to spot any grenades on the ground surface. Mr. Hayes said that when a nearby country club golf course was being graded and landscaped, a great deal of unexploded ordnance was uncovered & hauled away. He said he had seen mortars or similar objects on privately-owned land.

Mr. John E. Gosset, Sr. of Spartanburg was a maintenance engineer at Camp Croft during the war years and is a long-time resident whose extended family now owns several hundred acres of the former DOD property. Mr. Gosset said he had seen detailed maps of the artillery ranges, mortar ranges, rifle ranges, and other areas within the camp. Attempts to locate these maps have thus far been unsuccessful. Mr. Gosset said that the Explosive Ordnance Disposal unit at Fort Jackson, Columbia, S.C., had come out to remove or explode ordnance which had been discovered over the years, both inside and outside the State Park boundaries, but none was ever found on his lands. A number of other residents or property owners said that they had either seen or heard of unexploded ordnance on former DOD property, but such discoveries appear to have been less frequent in recent years.

Master Sergeant High of the 48th Explosive Ordnance Disposal (EOD) unit at Fort Jackson, S.C., said that over the past year they had not been called to the Camp Croft area, and that the previous year they went "one or two times" for ordnance disposal, but that prior to this, they had been going to Camp Croft about once a month to remove or explode old ordnance. Most were 60-80 mm practice mortars; some were practice mortars with fuses and spotting charges (dangerous, but not likely to throw shrapnel over a wide area); and a few were high explosives.

Stokes mortars with white phosphorus, plasticized white phosphorus, or gases may also have been used, but Sergeant High had no specific information on their use or existence at Camp Croft. He suggested that we might contact FORSCOM, Dep. Ops, Fort McPhearson, Georgia, for further information but that previous inquiries on his part had resulted in instructions from the Department of the Army not to pursue the inquiry further.

In summary, in spite of efforts to remove ordnance from Camp Croft before disposing of the property, there have been a number of incidents over the subsequent almost forty-year period which indicate that unexploded ordnance may still be present, either above or below ground, in a number of locations. The 19,044-acre area is too large to initiate a screening and removal program for the whole site. No ordnance disposal activity is recommended for FY 84. In FY 85, a more thorough search could be made for the detailed maps mentioned by Mr. Gosset. Once these or similar maps defining the ordnance storage and impact areas are available, the present owners of these specific areas could be questioned and a field survey and removal program could be outlined.

2. Project Scope. No action is proposed in any of the three subactivities in FY 84. No action is foreseen beyond FY 84 for building demolition and debris removal. In FY 85, a thorough search should be made to locate detailed maps of the old ranges, storage and disposal areas. If further investigation of these areas indicates that the extent of the waste or ordnance problems is severe enough to constitute a danger to property owners, park visitors, or the general public, a plan for screening, demolition or removal should be drawn up at that time.

3. Forecast for Construction Contract Award. N/A.

4. Potential for Adverse Environmental Impact. In the event that further investigation of the unexploded ordnance results in a demolition or removal

program, the adverse impacts will likely be limited to minor disturbance of soils and removal of vegetation. An assessment of impacts of destruction or removal of toxic or noxious wastes, if any are discovered, would have to wait until the nature and location of the wastes were determined..

5. Right-of-Entry Agreement. N/A at this time.

# SITE MAP

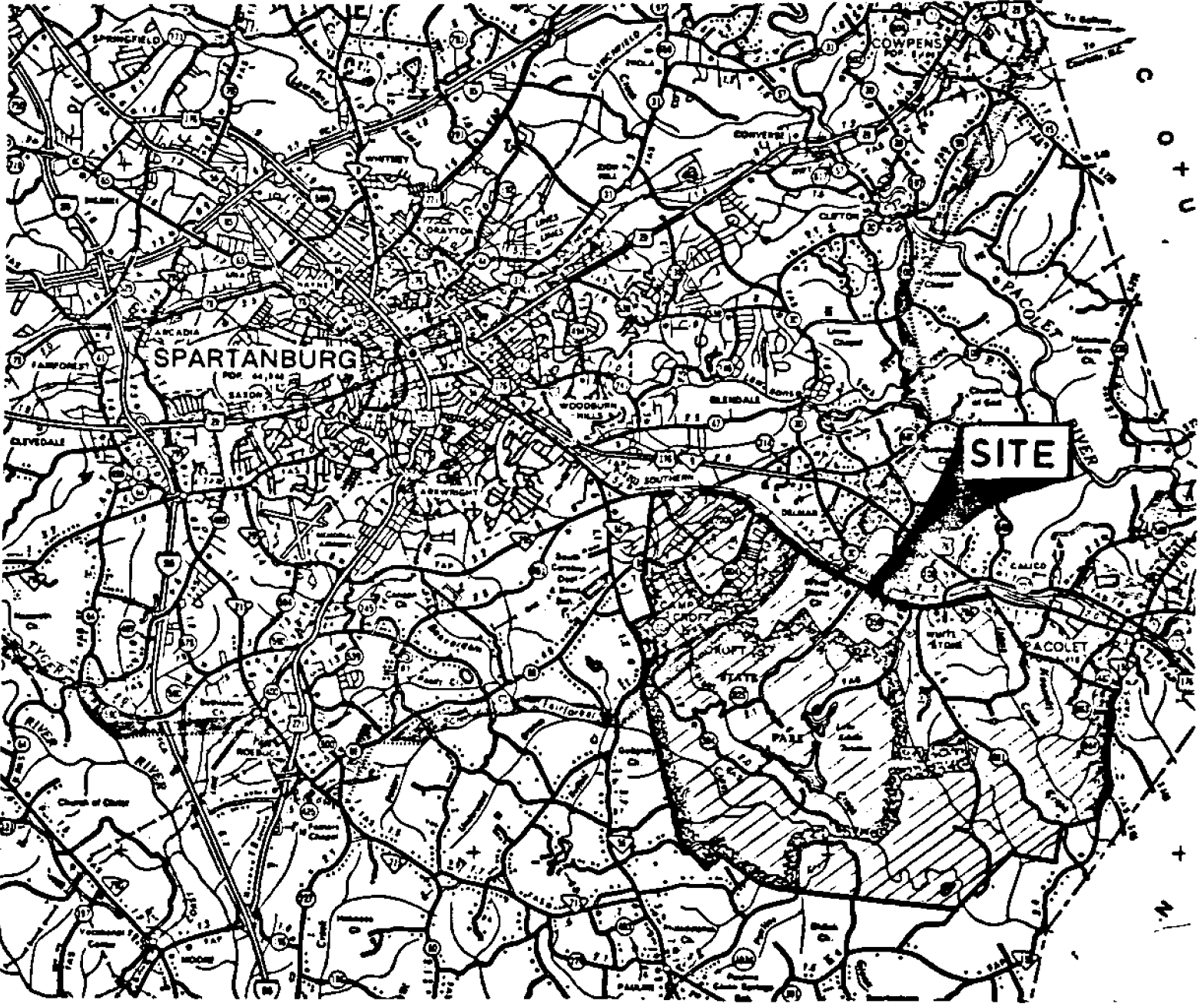

CAMP CROFT ARMY TRAINING FACILITY  
SPARTANBURG COUNTY, SOUTH CAROLINA  
SITE NO. I04SC001600

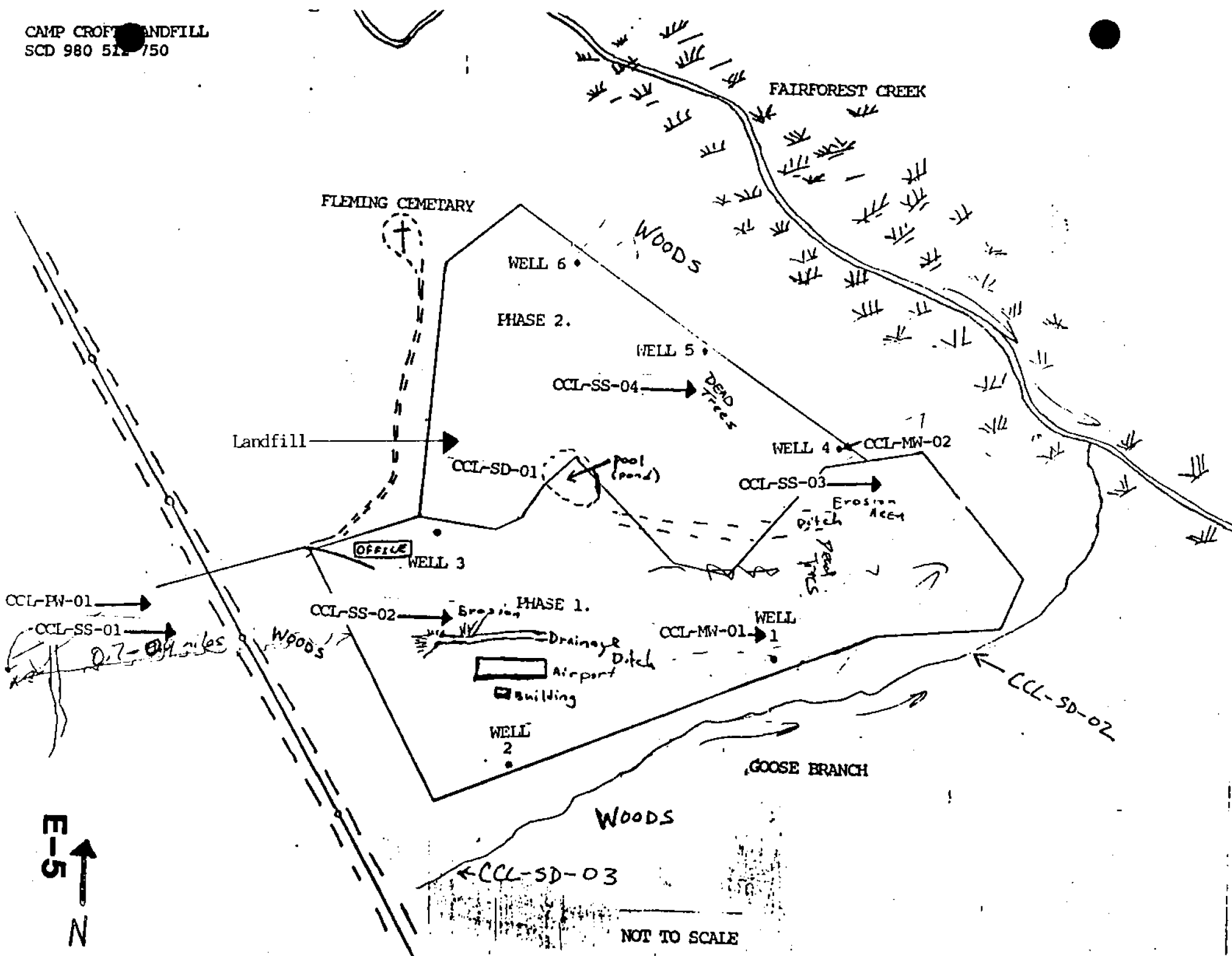

E-5  
↑  
N

NOT TO SCALE



Identify as  
Landfill →  
Add Plot Title:  
"Camp Croft Landfill: Domestic  
USE"

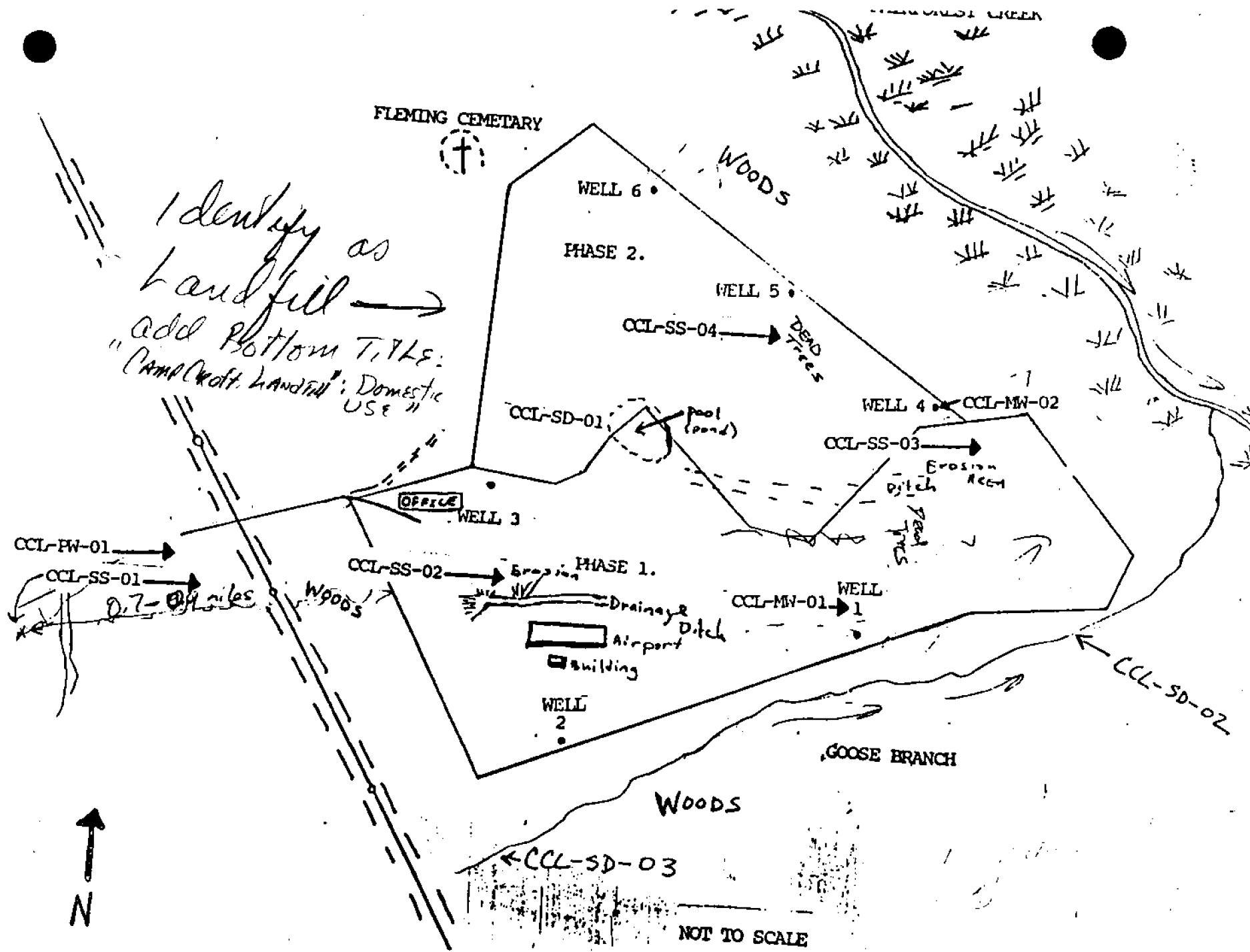

E-5

0  
A  
K  
R  
A  
P  
A

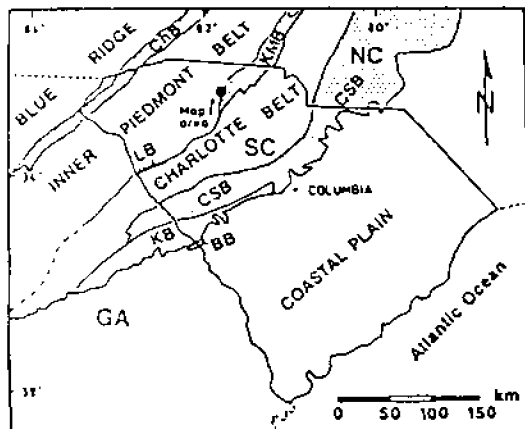

MAP KEY

- pgn-ogn paragneiss-orthogneiss
- bvs metamorphosed volcanic and sedimentary rocks (Battleground Formation)
- bjb manganiferous mica schist of the Jumping Branch Member of the Battleground Formation
- Dpmmc Devonian Pacolet Mills megacrystic granite
- hgs,p,g Hammett Grove Meta-igneous Suite
- gr unaltered granite
- db Mesozoic diabase dikes
- peg pegmatite dikes

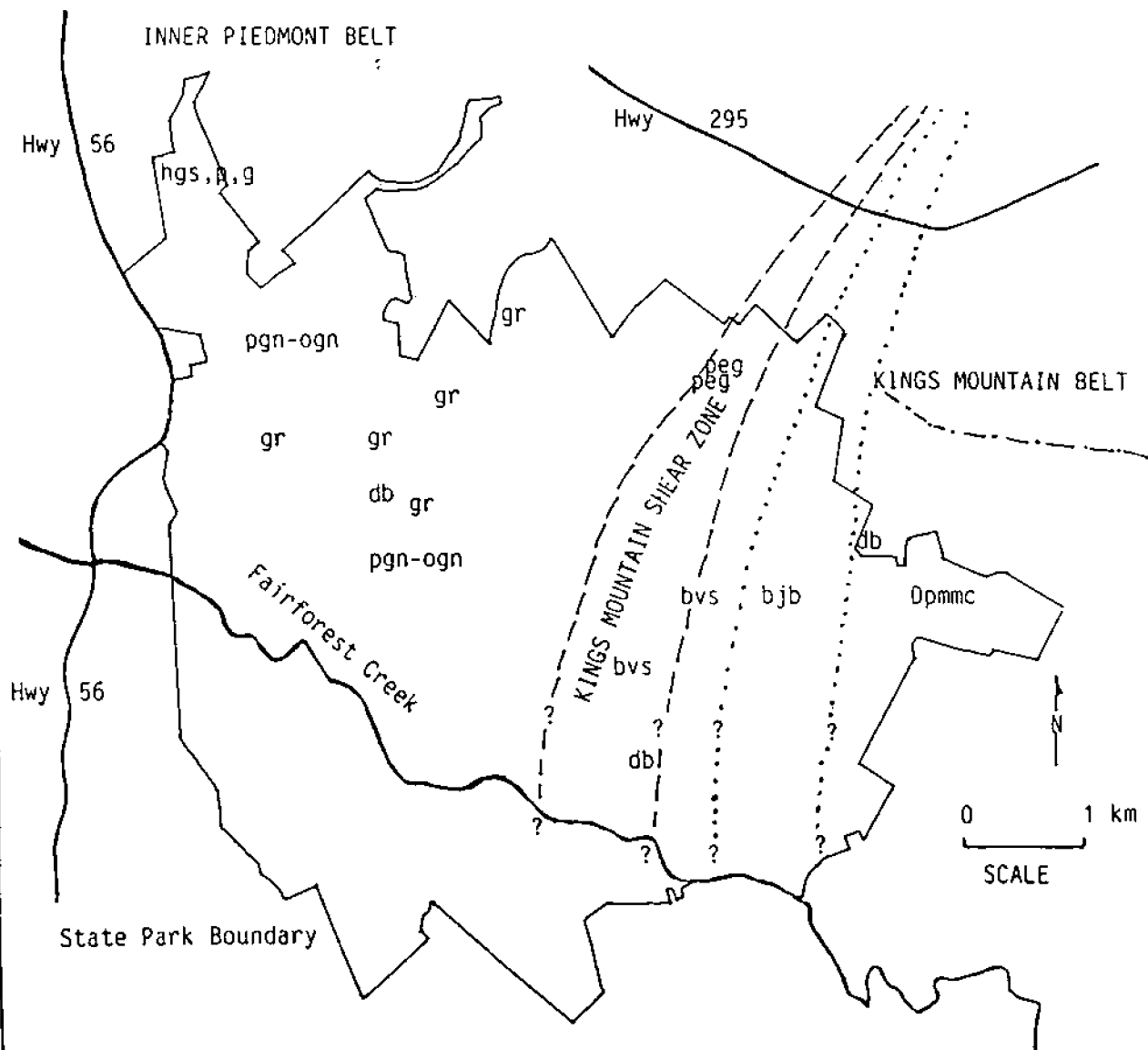

Generalized Geologic Map of Croft State Park  
 (adapted from Mittwede 1988,1989).  
 by Dr. T.A. Ferguson, Dept. of Geology  
 Wofford College, Spartanburg, SC.

# CRUISE

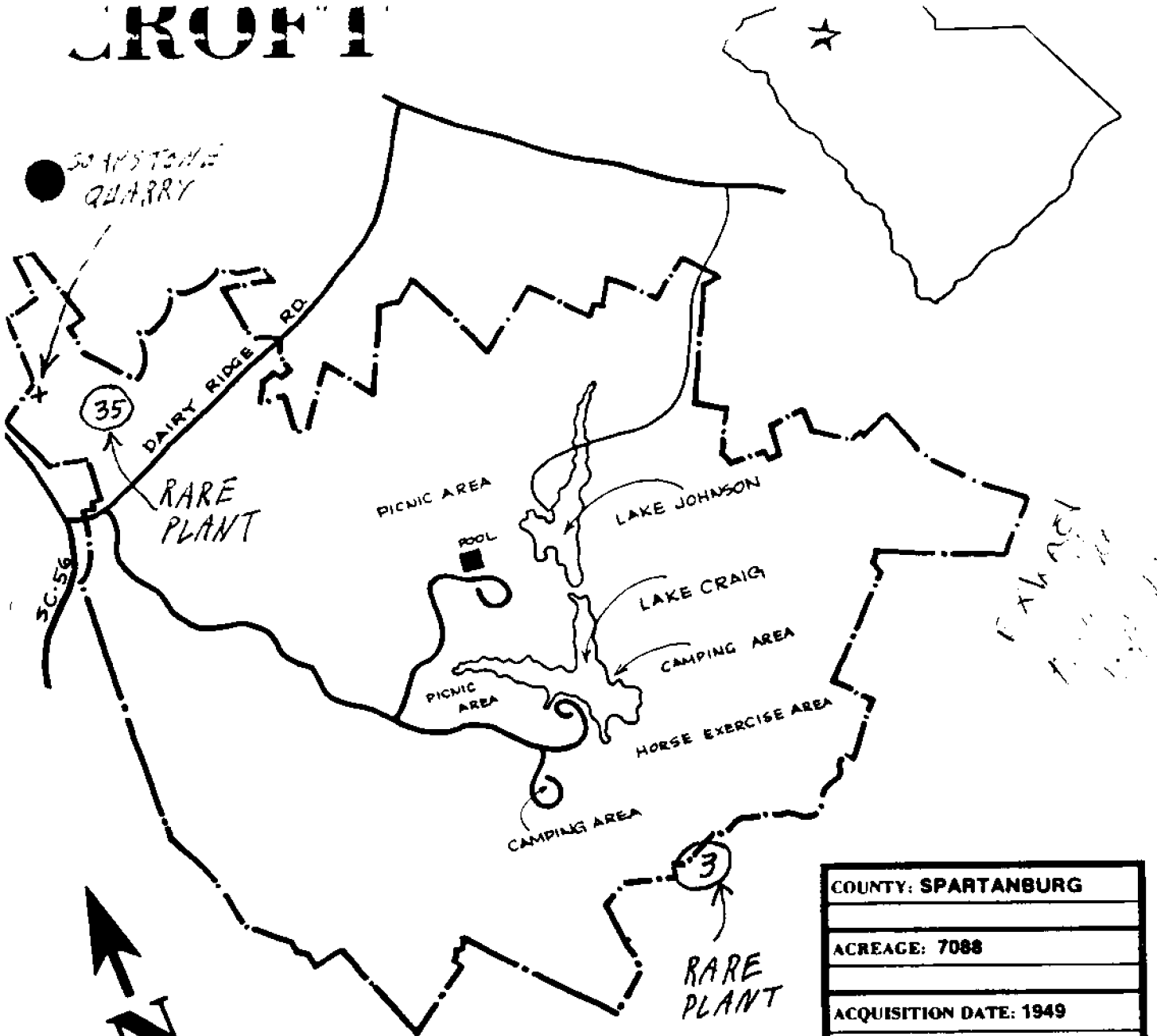

COUNTY: SPARTANBURG
ACREAGE: 7088
ACQUISITION DATE: 1949
TITLE DATA: PURCHASED U.S.
GOVERNMENT: REVERSIONARY FOR 20 YEARS

	CURRENT	POTENTIAL
A - PRESERVING NATURAL AREAS		
B - RECREATIONAL USE OF NATURAL RESOURCES		
C - INTERPRETING NATURAL HISTORY		
D-1 - PRESERVING HISTORIC SITES		
D-2 - INTERPRETING HISTORIC SITES		

ation & T  
Carolina

N STP  
2920

rish

E-7



SOUTH CAROLINA GEOLOGICAL SURVEY  
OPEN-FILE REPORT 64

**GEOLOGIC MAPS OF THE PACOLET AND  
PACOLET MILLS 7.5-MINUTE QUADGANGLES,  
SOUTH CAROLINA**

BY

STEVEN K. MITTWEDE  
SOUTH CAROLINA GEOLOGICAL SURVEY  
5 GEOLOGY ROAD  
COLUMBIA, SOUTH CAROLINA 29210-9998

SOUTH CAROLINA STATE BUDGET AND CONTROL BOARD  
DIVISION OF RESEARCH AND STATISTICAL SERVICES  
SOUTH CAROLINA GEOLOGICAL SURVEY

COLUMBIA, SOUTH CAROLINA

1989

## EXPLANATION FOR PLATES 1 and 2

### **KINGS MOUNTAIN BELT (CAROLINA TERRANE)**

- pcs -- metamorphosed and variably deformed plutonic rocks of the Polecat Creek meta-igneous suite; mostly of granodioritic to granitic composition (Plate 2); interpreted as subvolcanic intrusion.
- gb -- metamorphosed gabbro; two small bodies; that in east-central part of Pacolet Mills quadrangle possibly related to pcs; that in north-central part of Pacolet Mills quadrangle probably related to Blue Branch ultramafites (Plate 2).
- md -- metamorphosed (?) mafic dike, deeply weathered; within pcs at eastern edge of Pacolet Mills quadrangle (Plate 2).
- tc -- talc schist; one exposure near Goucher School; unknown affinity, possibly related to northwest-trending diabase dike (Plate 2).

#### **Battleground Formation:**

- bvmi -- metamorphosed mafic to intermediate (basaltic to andesitic) volcanic rocks; mainly amphibole gneiss and amphibolite, with minor amounts of felsic metavolcanic rocks (Plate 2).
- bvfi -- metamorphosed, schistose to gneissic, felsic to intermediate (rhyolitic to dacitic) volcanic rocks; mainly pyroclastic (lapilli, plagioclase crystal and quartz-crystal tuffs), but with some flows (Plate 2).
- bsvf -- quartz-sericite schist (locally pyritic) and felsic metavolcanic rocks (Plate 2); schist is interpreted to be altered volcanic rock.
- q -- quartzite; within bsvf unit (Plate 2).
- bvs -- metamorphosed, schistose to gneissic, volcanic and sedimentary rocks; some quartz-mica schist; rocks exposed in Big Blue Branch (north-central Pacolet Mills quadrangle) may be granodioritic intrusion; bvs also in south-central Pacolet quadrangle (Plate 1).
- bjb -- Jumping Branch Manganiferous Member; manganiferous mica schist with concordant layers of gondite; exposed on prominent south-trending ridge at White Stone (south-central Pacolet quadrangle, Plate 1).

mss -- mica schist and metasiltstone/metamudstone; adjacent to Bald Rock granite (Plate 2); questionably assigned to the Battleground Formation.

Hammett Grove Meta-igneous Suite (thrust slices or klippen):

hgs -- altered (steatitized and serpentized) ultra-mafites (metaperidotite); mostly soapstone, impure talc schist and antigorite serpentinite (Plate 1 and 2).

hgp -- metapyroxenite (Plate 1).

hgg -- metagabbro (Plates 1 and 2).

hgb -- amphibolitic metabasalt; best exposed in North Goucher Creek south of White Plains (Plate 2).

hgcr -- rodingitized metasediment (chert ?) and rodingite (Plate 1).

---

**INNER PIEDMONT BELT (PIEDMONT TERRANE)**

pgn-ogn -- paragneiss and orthogneiss; mainly biotite and granitic gneisses; with sparse amphibole gneiss and minor amounts of amphibolite (Plate 1 and 2).

am -- amphibolite, locally gneissic; as interlayers (basaltic flows ?) within pgn-ogn unit (Plates 1 and 2).

qms -- quartz-mica schist; locally contains aluminosilicates, garnets, or both (Plates 1 and 2).

---

Devonian Pacolet Mills pluton (syn-or post-metamorphic):

Dpmmc -- megacrystic (1-5 cm-long potassium feldspar), biotite-rich granite; probably granodioritic composition.

Dpmt -- fine- to medium-grained granitoid of tonalitic (?) composition; on west side of pluton (Plate 1).

Dpmgd -- medium- to coarse-grained to porphyritic granodiorite.

Dpmmg -- fine- to medium-grained monzogranite.

---





as -- aluminous mica schist; occurs as isolated roof pendants to Pacolet Mills pluton (contacts dotted).

brg -- Bald Rock granite (post-metamorphic); southeastern corner of Pacolet Mills quadrangle (Plate 2).

gr	--	undeformed granite; in pods or sills (syn- or post-kinematic).
db	--	Mesozoic diabase dike; outcrop or float boulders; long dike in northwestern quarter of Pacolet Mills quadrangle is informally named the Goucher Creek diabase dike.
qv	--	quartz vein.
sm	--	silicified microbreccia (Plate 2); in narrow rectilinear zones.
peg	--	granitic pegmatite; in dikes mainly near margins of Pacolet Mills pluton.

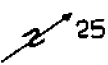
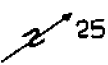
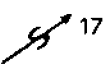
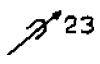
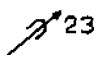
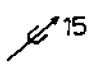
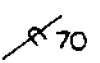
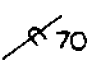
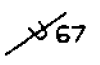
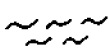
-----

### Symbols

-----	--	contact
	--	strike and dip of foliation and/or compositional layering
		bearing and plunge of fold axis showing asymmetry in down-plunge view
		dextral
		sinistral
		bearing and plunge of symmetrical fold surface
		antiformal
		synformal
		overturned fold, with attitude of axial surface
		antiform
		synform
x	--	instructive exposure, boulders, or preponderance of float material (within plutons).
	--	shear zone; narrow zones of Alleghanian ductile deformation, locally containing mylonites and asymmetrical shear crenulations (in Jones Creek shear zone, crenulations indicate right-lateral movement).
	--	sand dredging operation
	--	talc prospect
	--	gold prospect

⌘ Au -- inactive gold mine  
⌘ st -- active stone quarry  
⌘ st -- inactive stone quarry



ORDNANCE AND EXPLOSIVE WASTE  
ARCHIVES SEARCH REPORT  
FOR  
FORMER CAMP CROFT ARMY TRAINING FACILITY  
SPARTANBURG, SOUTH CAROLINA  
PROJECT NUMBER I04SC001603

APPENDIX F

LETTERS/MEMORANDUMS/CORRESPONDENCE

APPENDIX F

LETTERS/MEMORANDUMS/CORRESPONDENCE

Table of Contents

- 
- F-1 Letter, HQ, Infantry Replacement Training Center (IRTC), Camp Croft, SC, 23 August 1945, Subject: History of IRTC, Camp Croft, South Carolina
- F-2 Site Summary Sheet, DERP FUDS Site No. I04SC001600, Camp Croft Army Training Facility, Spartanburg, SC, 19 September 1991
- F-3 DERP FUDS FDE, Camp Croft Army Training Facility, Spartanburg, SC, Site No. I04SC001600, 25 November 1991
- F-4 Project Summary Sheet, DERP FUDS CON/HTW Project No. I04SC001601, Camp Croft Army Training Facility, Spartanburg, SC, Site No. I04SC001600, 19 September 1991
- F-5 Project Summary Sheet, DERP FUDS HTW Project No. I04SC001602, Camp Croft Army Training Facility, Spartanburg, SC, Site No. I04SC001600, 19 September 1991
- F-6 Project Summary Sheet, DERP FUDS OEW Project No. I04SC001603, Camp Croft Army Training Facility, Spartanburg, SC, Site No. I04SC001600, 19 September 1991
- F-7 Letter, DA, Office of the Chief Engineer, Ref: File No. 602, Camp Croft, SC, 20 December 1948
- F-8 Certificate of Deduinding, 9800th S.U.-O.E., Det #8, Bomb and Shell Disposal undated
- F-9 Memorandum For Record, USACE, SACEN-E (Steve Morrison), 15 August 1984, Subject: Site Visit to Camp Croft, Spartanburg
- F-10 Telephone Conversation between Steve Morrison, USACE, SACEN and John E. Gosset, Sr., Maintenance Engineer at Camp Croft during WWII, 20 August 1984
- F-11 Telephone Conversation between Steve Morrison, USACE, SACEN and MSG High, 48th EOD, Fort Jackson, SC, 23 August 1984
- F-12 Conversation Record between Jeff Beckner, Garraty and Miller and Robbin Blackman, USACE, SACEN, Subject: Camp Croft - Location of Wells, 8 October 1987
- F-13 Memorandum, DA, CESASRE-MM, 31 May 1989, Subject: DERP Real Estate Information for Camp Croft, SC
- F-14 "Note to Jim" from an employee, USACE, SACEN, 5 September 1990

F-15 Telephone Conversations between Steve Holdeman, Corps of Engineers, Charleston District and Lt. Harold Hines, Spartanburg County Sheriff, Bomb Squad Unit; Sgt Craig, 48th EOD, Fort Jackson, SC; Keith Windham, Park Superintendent, Croft State Park; Greg Henschel, Narcotics Division, Columbia, SC (formerly of the 48th EOD), 5 September 1990, Subject: Calls Related to Ordnance at Camp Croft.

F-16 Sketch, CESAC, Rifle Range, Whitestone area, Camp Croft, 19 June 1991

F-17 Memorandum, USACE, Charleston District, Planning Branch, October 15, 1991, Subject: Croft State Park and Vicinity, formerly Camp Croft Army Training Facility, DERP-FUDS Site No. I04SC001600

F-18 Memorandum, SC Department of Parks, Recreation and Tourism (PRT), Division of State Parks, October 29, 1991, Subject: Croft State Park, formerly Camp Croft Army Training Facility, DERP-FUDS Site No. I04SC001600

F-19 Conversation Record between Joe Watson, Chief Naturalist, SC Department of PRT and Wayne Bogan, Jr. USACE, Charleston District, 30 October 1991, Subject: Camp Croft - Recently discovered Mortar, Live

F-20 Conversation Record between 48th EOD staff, Ft. Jackson, SC and Wayne Bogan, Jr., USACE, Charleston District, 30 October 1991, Subject: Mortar Round at Camp Croft

F-21 Conversation Record between Walt Perro, USACE, Huntsville Division and Wayne Bogan, Jr., USACE, Charleston District, 30 October 1991, Subject: Mortar Round at Camp Croft

INDEX SHEET

File Under No.

314.7 Military Histories

SYNOPSIS

6/10/45  
314.7(25 Sep 45)

Subject:

12. HISTORIES OF SUBORDINATE UNITS, ARMY GROUND FORCES.

Histories prepared in compliance with letter, Hq AGF, 314.7/100 (16 Mar 44)GNHIS, 16 March 1944, Subject: "Histories of Subordinate Units, Army Ground Forces," will terminate as of 1 September 1945, and will be completed by 31 December 1945.

(314.7(25 Sep 45)GNHIS)

Documents filed under No.

INSTRUCTIONS: Under "Synopsis" make brief entry showing date of communication and from which received and synopsis sufficient to identify the papers. When these index sheets become numerous under a subject, they will be clustered on the consolidated index sheet and then destroyed.

HEADQUARTERS  
INFANTRY REPLACEMENT TRAINING CENTER  
Camp Croft, S. C.

GHRKA-GPG/mcc

314.7

23 August 1945

SUBJECT: History of IRTC, Camp Croft, South Carolina.

TO: Commanding General, Replacement and School Command,  
Army Ground Forces, Birmingham 3, Alabama.

Reference is made to letter your headquarters, file 314.7  
GHRSH, subject: "History of Subordinate Installations of Replacement  
and School Command", dated 17 August 1945. In compliance with para-  
graph 5 of reference letter, there is inclosed one copy of a brief  
history of this IRTC.

FOR THE COMMANDING GENERAL:

GEORGE P. GILLAN,  
Major, AGD,  
Adjutant General.

1 Incl.  
History of IRTC, CpCroft.

FILE COPY

314.7  
GHRSH  
GPG/mcc

HEADQUARTERS  
INFANTRY REPLACEMENT TRAINING CENTER  
Camp Croft, S. C.

BRIEF HISTORY OF IRTC, CAMP CROFT, SOUTH CAROLINA

Following is a brief, largely chronological, record of major operational events in the history of Camp Croft, South Carolina to date.

10 February 1941. The Infantry Replacement Center at Camp Croft was activated, in pursuance of a letter from the Secretary of War, subject: "Replacement Centers", dated 25 October 1940, and 2nd indorsement thereto by Headquarters 4th Corps Area dated 29 January 1941. The battalions assigned to this replacement center were redesignated on this date. The old or original designation was 1st to 18th, inclusive, and the new designation given was 26th to 40th, inclusive, and the 50th Battalions.

Following are the dates of activation of the battalions together with type of training to be given in each one.

6 May 1941	26th Bn.	Hq Co Specialists
6 May 1941	27th Bn.	Serv Co Specialists Cos E & F (Col)
6 May 1941	28th Bn.	A-T Co
6 May 1941	29th Bn.	HW Co
6 May 1941	30th Bn.	HW Co
20 Feb 1941	31st Bn.	HW Co
13 Feb 1941	32nd Bn.	Rifle Co
19 Feb 1941	33rd Bn.	" "
13 Feb 1941	34th Bn.	" "
19 Feb 1941	35th Bn.	" "
17 Feb 1941	36th Bn.	" "
19 Feb 1941	37th Bn.	" "
18 Feb 1941	38th Bn.	" "
17 Feb 1941	39th Bn.	" "
18 Feb 1941	40th Bn.	" "
20 Feb 1941	50th Bn.	" " (Col)

15 February 1941, the Hq and Hq Detachment, 6th Infantry Training Group was activated, and designated to act as Headquarters of the Replacement Center.

20 March 1941, the Hq and Hq Detachment, 7th Infantry Training Group was activated. Incorporated in this group were ten battalions, the 32nd to 40th and the 50th Bn (Col). All of these battalions were rifle battalions.

14 April 1941, the 8th Infantry Training Group was activated. This group included the 26th to 30th Bns, inclusive. These battalions were Specialist and Heavy Weapons Companies as noted above.

7 September 1941. Co. D, 40th ITR inactivated; activated Co D, Special Training Battalion.

20 October 1941. The Center was reorganized on this date as follows:

Headquarters, Infantry Replacement Training Center.

Headquarters Co, IRTC.

Hq. & Hq. Det, 6th Infantry Training Regiment, 32nd to 36th Bns.

Hq. & Hq. Det, 7th Infantry Training Regiment, 37th to 40th Bns.

Hq. & Hq. Det, 8th Infantry Training Regiment, 26th to 28th Bns.

Hq. & Hq. Det, 9th Infantry Training Regiment, 29th, 30th, 31st & 60th Bns.

The 6th, 7th and 8th Infantry Training Groups were inactivated.

18 April 1942. The Hq. & Hq. Det, 10th Infantry Training Regiment were activated. The 50th Bn. was transferred from the 9th to the 10th Infantry Training Regiment.

6 May 1942. Co. C, 40th ITR inactivated and activated as Co C, Special Training Unit, 40th ITR.

18 July 1942. 49th ITR activated. Cos E & F of the 27th Bn (now attached to the 50th Bn for administration) are assigned to the 49th Bn, and redesignated as Cos A & B, 49th ITR.

The 36th ITR is transferred from the 6th ITR to the 7th ITR.

The 28th ITR is transferred from the 8th ITR to the 9th ITR.

The 40th ITR is relieved from the 7th ITR, redesignated as the 40th ITR (Special Training Unit) and under direct control of IRTC Hq.

4 September 1942. IRTC and Station Complement become separate commands.

19 April 1943. 71st Replacement Battalion activated, attached to 6th ITR.

25 April 1943. Infantry Officer Replacement Pool activated.

17 May 1943. 71st Replacement Battalion relieved from attached to 6th ITR.

9 August 1943. The 40th Bn, Special Training Unit, is inactivated as such and activated as the 40th ITR and assigned to the 7th ITR. Co E, 40th ITR, is activated as a Special Training Unit.

19 October 1943. Hq. & Hq. Det, 8th ITR, inactivated.  
26th and 27th ITB's designated separate ITB's.

1 November 1943. The following units are inactivated:

Hq. & Hq. Det, 10th ITR  
Co C, 40th ITB  
Co S, Special Training Unit, 40th ITB  
Co B, 49th ITB  
Cos A and D, 50th ITB.

2 November 1943. Cos in 71st Replacement Battalion redesignated as follows:

Co A, 71st Replacement Bn - 230 Repl Co.  
Co B, 71st Replacement Bn - 231 Repl Co.  
Co C, 71st Replacement Bn - 232 Repl Co.

30 November 1943. 71st Replacement Battalion transferred to A. S. F.

1 December 1943. Co B, 50th ITB inactivated.

13 January 1944. Co A, 49th ITB and Co B, 50th ITB, inactivated.  
Co D, 40th ITB, is redesignated as Co C, 40th ITB.

15 January 1944. Hq. & Hq. Det, 50th ITB, inactivated.  
49th ITB is inactivated.

13 March 1944. 41st ITB organized and assigned to the 9th ITR (Rifle Bn.).

20 March 1944. 8th ITR organized. Composed of the following battalions:

26th ITB - Hq Cos  
27th ITB - Serv Cos  
29th ITB - AT Cos - to be converted to Service Companies as each A-T  
Company completes its present cycle.

8 April 1944. WAC Detachment organized.

8 November 1944. WAC Detachment disbanded.

20 December 1944. FA Detachment organized.

12 January 1945. FA Detachment discontinued, absorbed by Hq Co, IRTC.

19 March 1945. WAC Detachment organized.

The total number of men ordered into this center since its activation through 31 July 1945 is 199,839; the number shipped out during that period is 181,925.



The following officers have commanded the Infantry Replacement Training Center at Camp Croft, S. C.

10 February 1941	to	27 March 1941	L. A. Kunsig, Col, Inf. -
28 March 1941	to	14 August 1941	O. W. Griswold, Brig Gen, USA -
15 August 1941	to	19 August 1941	W. G. Jones, Lt Col, Inf.
20 August 1941	to	24 August 1941	T. D. Finley, Col, Inf.
25 August 1941	to	19 January 1942	A. M. Patch, Brig Gen, USA -
20 January 1942	to	26 January 1942	L. C. Davidson, Col, Inf.
27 January 1942	to	25 February 1942	C. E. Ertner, Col, Inf.
28 February 1942	to	8 March 1942	L. C. Davidson, Col, Inf.
9 March 1942	to	23 June 1942	P. L. Ransom, Brig Gen, USA
24 June 1942	to	18 October 1942	C. F. Thompson, Maj Gen, USA
19 October 1942	to	8 November 1942	R. W. Bussell, Brig Gen, USA
9 November 1942	to	28 May 1944	D. S. Wilson, Maj Gen, USA
27 May 1944	to	25 June 1944	F. V. Logan, Brig Gen, USA -
26 June 1944	to	date	J. H. Hester, Maj Gen, USA -

SITE SURVEY SUMMARY SHEET  
FOR  
CAMP CROFT ARMY TRAINING FACILITY, SC  
19 SEPTEMBER 1991

SITE NAME: Formerly Camp Croft Army Training Facility.

LOCATION: Located southeast of the city of Spartanburg in Spartanburg County, South Carolina; see vicinity and site maps attached.

SITE HISTORY: Camp Croft was used as an infantry replacement training center for the Army Ground Forces, Fourth Service Command. Infantry units were trained along with artillery and mortar units from 1941 to 1944. The site was disposed of in 1947.

7400  
The site consisted of 19,044.46 acres which is today used as a state park, industrial area, and residential area. Detailed maps of the site were not found. Through interviews, however, it was determined that much of the ammunition and waste used at the site was buried when the site was closed. This equipment was often buried in trenches or not buried at all. Over the past twenty years, there have been numerous instances where citizens have found ordnance in the form of grenades and small arms ammunition. As many as 80 grenades were found in one location by a Reserve unit that was on maneuvers in the area. The state park has restricted the use of metal detectors which has decreased the number of reports of ordnance. There are reports, however, where local residents removed six to twelve pieces of ordnance per house being constructed in some areas. Much of the ordnance is expected to be buried below the surface.

SITE VISIT: A site visit was conducted on 19 June 1991 by Cheryl Peyton, Wayne Bogan, and Rodney Reid, CESAC-EN-PR. They visited the Spartanburg County Courthouse and spoke with Keith Windon at Camp Croft State Park. A previous site visit was conducted on 12 August 1984. On 5 September 1990, Keith Windon, Croft State Park Superintendent; Lt. Harold Hines of the Spartanburg County Bomb Disposal Unit; Greg Henschel, formerly of the 48 Ordnance Disposal Unit; and Staff Sergeant Craig, currently with the 48th Explosive Unit; were contacted regarding the site.

CATEGORY OF HAZARD: CON/HTW, HTW, OEW.

PROJECT DESCRIPTION:

- a. CON/HTW. Interviews revealed that during the closure of the site, drums and other materials were placed in wells which were then closed.
- b. HTW. A landfill, possibly containing medical wastes is located on the site where a hospital stood.

c. BD/DR. No further action. There is no evidence of BD/DR for which the Government is responsible at this site.

d. OEW. A tremendous amount of ordnance is located on the site, including live mortars, grenades, rockets, and chemical weapons. A 44-acre tract of land was restricted to surface use only due to its use as an impact area.

AVAILABLE STUDIES AND REPORTS: Site Inspection Report, Camp Croft Landfill, Department of Health and Environmental Control, 30 March 1990.

Site Survey Summary Report, CESAC-EN-E, August 1984.

PROJECT POC: Wayne Bogan, (803) 724-4366 is the Charleston District POC.

# VICINITY MAP

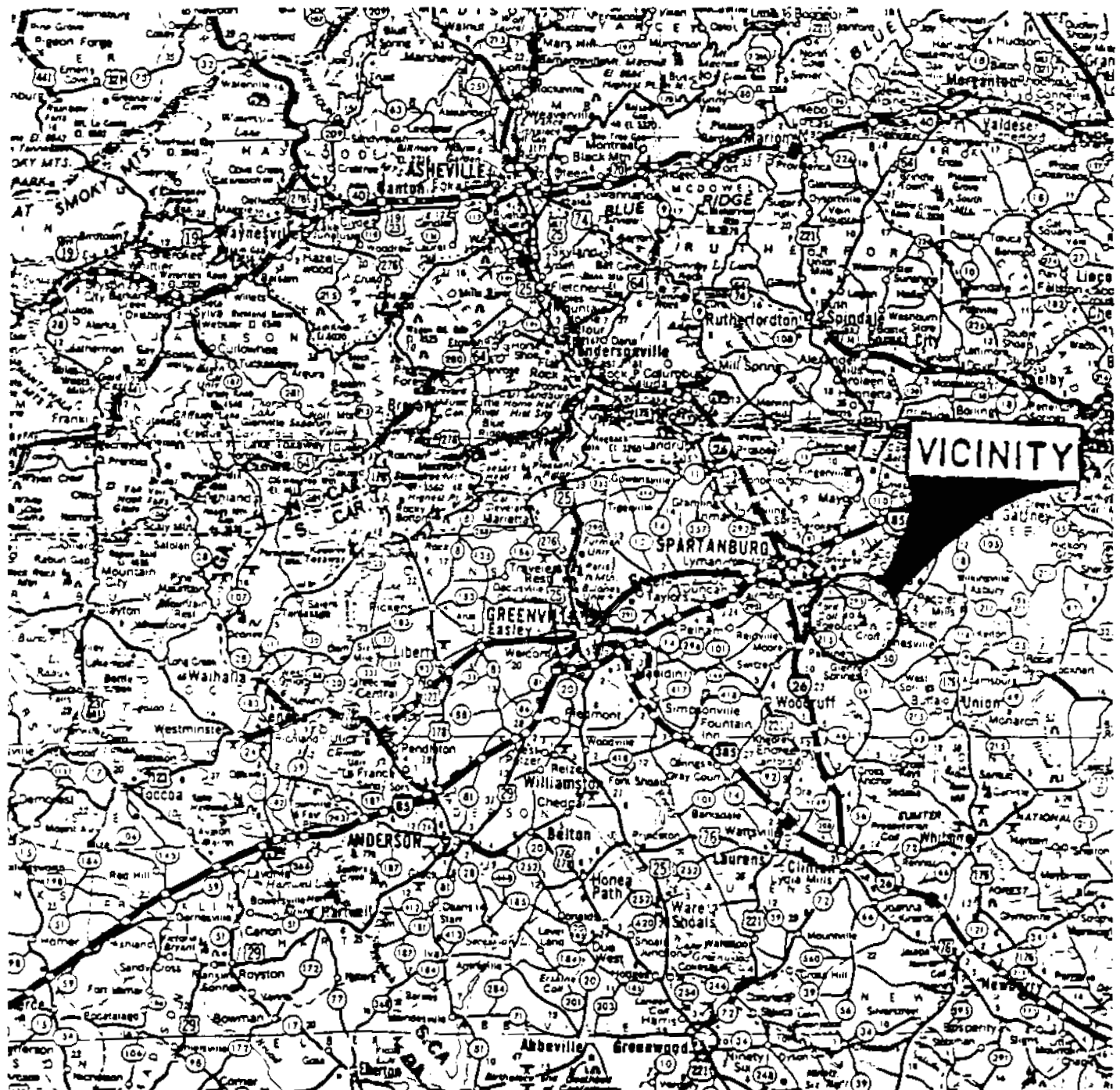

CAMP CROFT ARMY TRAINING FACILITY  
SPARTANBURG COUNTY, SOUTH CAROLINA  
SITE NO. I04SC001600

# SITE MAP

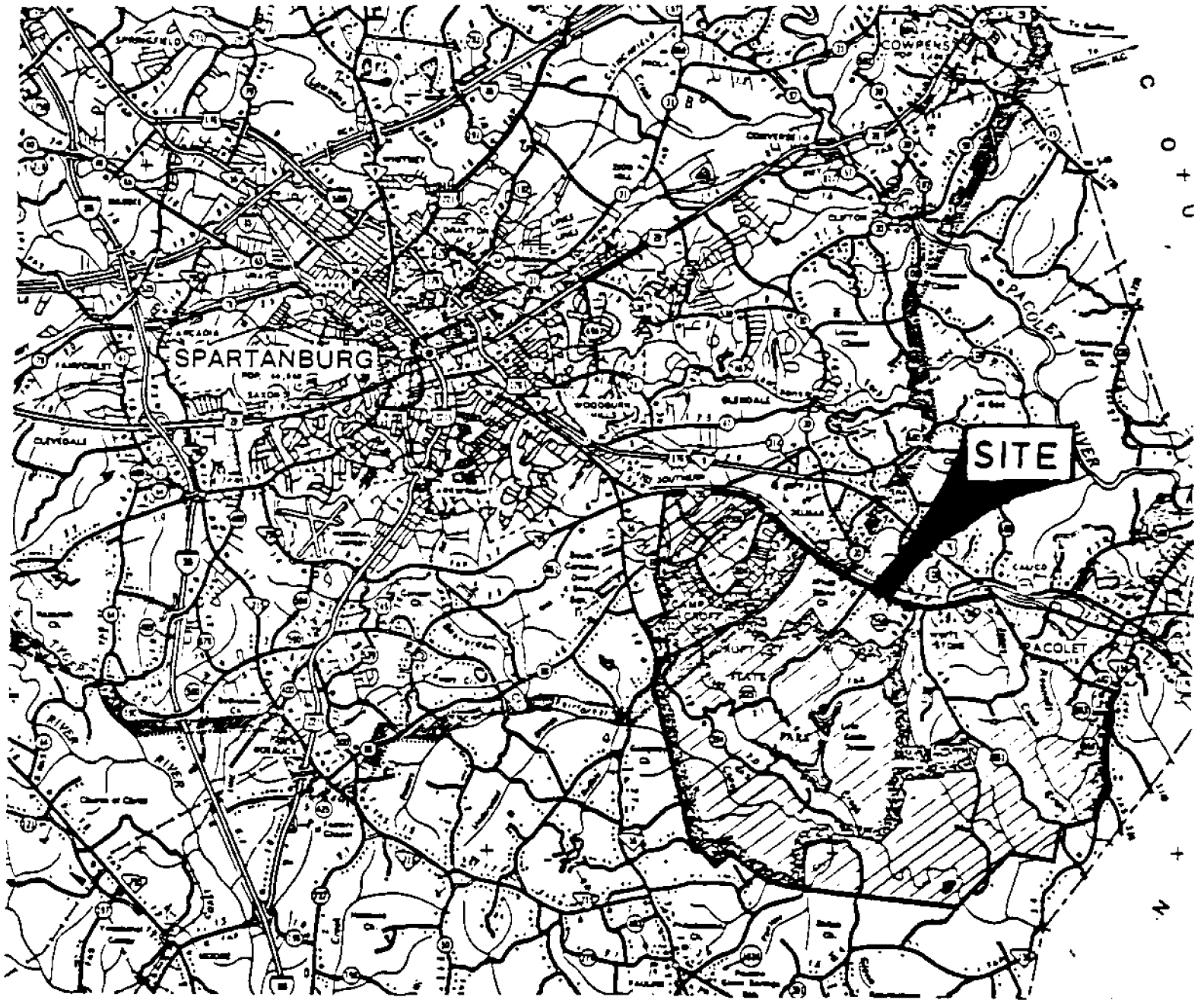

CAMP CROFT ARMY TRAINING FACILITY  
SPARTANBURG COUNTY, SOUTH CAROLINA  
SITE NO. I04SC001600

DEFENSE ENVIRONMENTAL RESTORATION PROGRAM  
FORMERLY USED DEFENSE SITES PROGRAM  
FINDINGS AND DETERMINATION OF ELIGIBILITY

CAMP CROFT, SOUTH CAROLINA  
SITE NO. I04SC001600

FINDINGS OF FACT

1. Camp Croft was located three miles southeast of the city of Spartanburg, in Spartanburg County, South Carolina. Between 1941 and 1944, the United States acquired 19,044.46 acres comprising 19,039.04 acres in fee, 5.42 acres in easement interests, six no-area easements, and two no-area licenses. Acquisition was accomplished by condemnation. The no-area easements were for sewer line rights-of-way. One no-area license was for fencing, and the other for waterline right-of-way.

2. Camp Croft, also known as Camp Croft Military Reservation, was utilized as an infantry replacement training center for the Army Ground Forces under the command of the Fourth Service Command. Improvements to the site consisted of administrative buildings, mess halls, barracks, a hospital, warehouses, chapels, and a stockade to house prisoners of war.

3. In 1947, the War Department declared 19,044.46 acres comprising 19,039.04 acres of fee land and 5.42 acres in easement interests excess to the War Assets Administration. Amendments to the original Declaration of Surplus noted presence of ordnance and mustard gas on the installation. In 1947, 2.14 acres of easement interests were conveyed to Duke Power Company by quitclaim deed, 7.70 acres of fee land and improvements were transferred by letter to the Federal Public Housing Authority, and the Federal Farm Mortgage Administration disposed of 4,936.24 acres of fee land by 45 separate quitclaim deeds without recapture provisions. In 1948, a quitclaim deed conveyed 0.34 of an acre of fee land and improvements to Upper South Carolina Conference of the Methodist Church and by a separate quitclaim deed conveyed an additional 0.34 of an acre of fee land and improvements to Spartanburg First Baptist Church. In 1949, 7,088.08 acres of fee land were conveyed by quitclaim deed to South Carolina Commission of Forestry, with the stipulation that the acreage be used for public parks and recreation for a 20-year period, restricting 44 acres of the conveyance to land surface use only and stipulating recapture provisions. Real Estate files reflect that 1,118.72 acres of fee land were sold to Spartanburg County Foundation, and 5,886.83 acres of fee land and 3.28 acres of easement interests were disposed of by quitclaim deed to former owners, veterans, and non priority holders without recapture; however, though these conveyances were referenced, no documentation to substantiate these conveyances was part of real estate audit files. The quitclaim deed conveying the 7,088.08 acres to the South Carolina Commission of Forestry should have recorded acreage at 7,088.68 acres, which accounts for 0.60 of an acre of the discrepancy in disposal of the land acquired for the installation. The remaining 0.19 of an acre discrepancy is unaccounted for in the disposal information.

SITE NO. I04SC001600

DETERMINATION

Based on the foregoing Findings of Fact, the site has been determined to be formerly used by Department of Defense. It is therefore eligible for the Defense Environmental Restoration Program - Formerly Used Defense Sites established under 10 USC 2701, et seq.

25 Nov 1991

DATE

John F. Sobke

JOHN F. SOBKE  
Major General, USA  
Commanding

PROJECT SUMMARY SHEET  
FOR  
DERP-FUDS CON/HIW PROJECT I04SC001601  
CAMP CROFT ARMY TRAINING FACILITY  
SITE NO. I04SC001600  
19 SEPTEMBER 1991

PROJECT DESCRIPTION: The site contains several locations where drums were placed inside wells during closure procedures at the site.

PROJECT ELIGIBILITY: The contents of the drums are unknown and are potential sources of environmental contaminants.

POLICY CONSIDERATIONS: There has been no beneficial use of the wells or drums since Department of Defense (DOD) usage.

PROPOSED PROJECT: The project consists of:

- a. locating and testing the contents of the drums,
- b. removing, overpacking, and disposing of all located drums, and
- c. restoring all disturbed areas.

DD FORM 1391: Attached.

DISTRICT POC: Wayne Bogan, CESAC-EN-FR, (803) 724-4366.



1. COMPONENT ARMY		FY 19__ MILITARY CONSTRUCTION PROJECT DATA			2. DATE 19 SEP 91	
3. INSTALLATION AND LOCATION Camp Croft			4. PROJECT TITLE Remove Drums			
5. PROGRAM ELEMENT		6. CATEGORY CODE CON/HTW	7. PROJECT NUMBER I045C001601	8. PROJECT COST (\$000) 22.6		
9. COST ESTIMATES						
ITEM		U/M	QUANTITY	UNIT COST	COST (\$000)	
Construction					10.0	
Contingency - 10%					1.0	
Subtotal					11.0	
S&A - 8%					0.9	
Design - 6%					0.7	
Field Investigation and Lab Fees					5.0	
Environmental Assessment					5.0	
Total					22.6	
10. DESCRIPTION OF PROPOSED CONSTRUCTION						
<ul style="list-style-type: none"> <li>- Locate and sample wells</li> <li>- Remove drums if found</li> <li>- Test groundwater and soil</li> <li>- SHERP - Safety Health and Emergency Response Plan</li> </ul>						

PROJECT SUMMARY SHEET  
FOR  
DERP-FUDS HTW PROJECT I04SC001602  
CAMP CROFT ARMY TRAINING FACILITY  
SITE NO. I04SC001600  
19 SEPTEMBER 1991

PROJECT DESCRIPTION: The site may contain soil and groundwater contamination due to the leakage of drums containing hazardous and toxic wastes in wells where they were dumped during the closure of the site. The wells were closed after drums and other materials were dumped in them.

The site also is reported to contain a landfill near the hospital and several trenches where excess items were buried during the closure of the site. The landfill may contain medical wastes. Several unused x-ray machines were uncovered during subsequent construction on the site.

PROJECT ELIGIBILITY: The possibility of leaking drums and other contaminants in the wells, landfill, and trenches are potential sources of environmental contaminants.

POLICY CONSIDERATIONS: No record exists of use of the wells, landfill, or trenches since the Department of Defense (DOD) occupancy.

PROPOSED PROJECT: The project consists of:

- a. determining the extent, if any, of soil and groundwater contamination on the site,
- b. remediating soil and groundwater contamination, and,
- c. restoring the site to background conditions.

EPA Form 2070-12: Attached

DISTRICT POC: Wayne Bogan, CESAC-EN-PR, (803) 727-4366.

 <b>POTENTIAL HAZARDOUS WASTE SITE PRELIMINARY ASSESSMENT PART I - SITE INFORMATION AND ASSESSMENT</b>				<b>I. IDENTIFICATION</b> <small>01 STATE OF SITE NUMBER</small> SC 104SC001600	
<b>II. SITE NAME AND LOCATION</b>					
<small>01 SITE NAME (Local, National, or International name of site)</small> Camp Croft			<small>02 STREET ROUTE NO. OR SPECIFIC LOCATION IDENTIFIER</small> Hwy 295		
<small>03 CITY</small> Spartanburg		<small>04 STATE</small> SC	<small>05 ZIP CODE</small> 29302	<small>06 COUNTY</small> Spartanburg	<small>07 COUNTY OR CONG. DIST. CODE</small> 
<small>08 COORDINATES - LATITUDE</small>		<small>LONGITUDE</small>			
<small>10 DIRECTIONS TO SITE (Indicate the nearest street name)</small> The site is along Hwy 295 covering areas from Pacolet to Whitestone to Spartanburg.					
<b>III. RESPONSIBLE PARTIES</b>					
<small>01 OWNER of waste</small> Department of Defense (not current owner)			<small>02 STREET (Name, No., Address)</small> Hwy 295		
<small>03 CITY</small> Spartanburg		<small>04 STATE</small> SC	<small>05 ZIP CODE</small> 29302	<small>06 TELEPHONE NUMBER</small> ( )	
<small>07 OPERATOR of waste and off-site site control</small> SC State Parks			<small>08 STREET (Name, No., Address)</small>		
<small>09 CITY</small>		<small>10 STATE</small>	<small>11 ZIP CODE</small>	<small>12 TELEPHONE NUMBER</small>	
<small>13 TYPE OF OWNERSHIP (Check one)</small> <input type="checkbox"/> A PRIVATE <input type="checkbox"/> B FEDERAL <input checked="" type="checkbox"/> C STATE <input checked="" type="checkbox"/> D COUNTY <input type="checkbox"/> E MUNICIPAL <input checked="" type="checkbox"/> F OTHER residential <input type="checkbox"/> G UNKNOWN					
<small>14 OWNER/OPERATOR NOTIFICATION ON FILE (Check one)</small> <input type="checkbox"/> A RCRA 3001 DATE RECEIVED _____ <input type="checkbox"/> B UNCONTROLLED WASTE SITE (RCRA 112) DATE RECEIVED _____ <input type="checkbox"/> C NONE					
<b>IV. CHARACTERIZATION OF POTENTIAL HAZARD</b>					
<small>01 ON SITE INSPECTION</small> <input checked="" type="checkbox"/> YES    DATE <u>06/19/91</u> <input type="checkbox"/> NO		<small>07 CHECK OF THE SITE</small> <input type="checkbox"/> A. EPA <input type="checkbox"/> B. EPA CONTRACTOR <input type="checkbox"/> C. STATE <input type="checkbox"/> D. OTHER CONTRACTOR <input type="checkbox"/> E. LOCAL HEALTH OFFICIAL <input checked="" type="checkbox"/> F. OTHER SAC, Corps of Engineers			
<small>CONTRACTOR NAME(S):</small>					
<small>02 SITE STATUS (Check one)</small> <input type="checkbox"/> A. ACTIVE <input checked="" type="checkbox"/> B. INACTIVE <input type="checkbox"/> C. UNKNOWN		<small>03 YEARS OF OPERATION</small> _____ 1961 _____ 1966 _____ <small>(BEGINNING YEAR) (ENDING YEAR)</small> <input type="checkbox"/> UNKNOWN			
<small>04 DESCRIPTION OF SUBSTANCES POSSIBLY PRESENT, KNOWN, OR ALLEGED</small> Possible contamination from drums and medical waste dumped into wells and landfills. Possible that drums may contain chemical weapons.					
<small>05 DESCRIPTION OF POTENTIAL HAZARD TO ENVIRONMENT AND/OR POPULATION</small> The potential hazards are groundwater contamination, surface water contamination fire/explosive conditions (unexploded ordnance) and soil contamination.					
<b>V. PRIORITY ASSESSMENT</b>					
<small>01 PRIORITY FOR INSPECTION (Check one) (High or medium is defined in Section 2.1. Status determined per Part 2. Inspection of potential Contaminants and activities)</small> <input type="checkbox"/> A. HIGH <input checked="" type="checkbox"/> B. MEDIUM <input type="checkbox"/> C. LOW <input type="checkbox"/> D. NONE					
<b>VI. INFORMATION AVAILABLE FROM</b>					
<small>01 CONTACT</small> WAYNE BOGAN		<small>02 OF Agency Organization</small> SAC, CORPS OF ENGINEERS		<small>03 TELEPHONE NUMBER</small> '803' 724-4366	
<small>04 PERSON RESPONSIBLE FOR ASSESSMENT</small> WAYNE BOGAN		<small>06 AGENCY</small> SAC	<small>08 ORGANIZATION</small> CORPS OF ENGINEERS	<small>07 TELEPHONE NUMBER</small> '803' 724-4366	<small>09 DATE</small> <u>09/18/91</u> <small>(MONTH DAY YEAR)</small>

EPA FORM 2070-12 (7-81)





POTENTIAL HAZARDOUS WASTE SITE  
PRELIMINARY ASSESSMENT  
PART 3 - DESCRIPTION OF HAZARDOUS CONDITIONS AND INCIDENTS

L IDENTIFICATION  
01 STATE SC 02 SITE NUMBER IO4SC001600

## E. HAZARDOUS CONDITIONS AND INCIDENTS

01  A GROUNDWATER CONTAMINATION 02  OBSERVED (DATE \_\_\_\_\_)  POTENTIAL  ALLEGED  
03 POPULATION POTENTIALLY AFFECTED \_\_\_\_\_ 04 NARRATIVE DESCRIPTION  
Possible contamination from drums and medical waste placed in wells and landfills. Possible contamination from chemical weapons. Possible hazardous/toxic materials and unknown quantities of buried ordnance.

01  B SURFACE WATER CONTAMINATION 02  OBSERVED (DATE \_\_\_\_\_)  POTENTIAL  ALLEGED  
03 POPULATION POTENTIALLY AFFECTED \_\_\_\_\_ 04 NARRATIVE DESCRIPTION  
SEE A Above

01  C CONTAMINATION OF AIR 02  OBSERVED (DATE \_\_\_\_\_)  POTENTIAL  ALLEGED  
03 POPULATION POTENTIALLY AFFECTED \_\_\_\_\_ 04 NARRATIVE DESCRIPTION  
NONE NOTED

01  D FIRE/EXPLOSIVE CONDITIONS 02  OBSERVED (DATE \_\_\_\_\_)  POTENTIAL  ALLEGED  
03 POPULATION POTENTIALLY AFFECTED \_\_\_\_\_ 04 NARRATIVE DESCRIPTION  
SEE A Above  
Possible unexploded ordnance.

01  E DIRECT CONTACT 02  OBSERVED (DATE \_\_\_\_\_)  POTENTIAL  ALLEGED  
03 POPULATION POTENTIALLY AFFECTED \_\_\_\_\_ 04 NARRATIVE DESCRIPTION  
NONE NOTED

01  F CONTAMINATION OF SOIL 02  OBSERVED (DATE \_\_\_\_\_)  POTENTIAL  ALLEGED  
03 AREA POTENTIALLY AFFECTED \_\_\_\_\_ 04 NARRATIVE DESCRIPTION  
SEE A Above

01  G DRINKING WATER CONTAMINATION 02  OBSERVED (DATE \_\_\_\_\_)  POTENTIAL  ALLEGED  
03 POPULATION POTENTIALLY AFFECTED \_\_\_\_\_ 04 NARRATIVE DESCRIPTION  
SEE A Above

01  H WORKER EXPOSURE/INJURY 02  OBSERVED (DATE \_\_\_\_\_)  POTENTIAL  ALLEGED  
03 WORKERS POTENTIALLY AFFECTED \_\_\_\_\_ 04 NARRATIVE DESCRIPTION  
NONE NOTED

01  I POPULATION EXPOSURE/INJURY 02  OBSERVED (DATE \_\_\_\_\_)  POTENTIAL  ALLEGED  
03 POPULATION POTENTIALLY AFFECTED \_\_\_\_\_ 04 NARRATIVE DESCRIPTION  
SEE A Above  
Possible contamination from unexploded ordnance on state park and in residential areas.

EPA		POTENTIAL HAZARDOUS WASTE SITE PRELIMINARY ASSESSMENT PART 3 - DESCRIPTION OF HAZARDOUS CONDITIONS AND INCIDENTS		I. IDENTIFICATION	
				01 STATE SC	02 SITE NUMBER 10490001600
<b>II. HAZARDOUS CONDITIONS AND INCIDENTS</b> (continued)					
01 <input type="checkbox"/> J. DAMAGE TO FLORA 04 NARRATIVE DESCRIPTION	02 <input type="checkbox"/> OBSERVED (DATE _____)	<input type="checkbox"/> POTENTIAL	<input type="checkbox"/> ALLEGED		
NONE NOTED					
01 <input type="checkbox"/> K. DAMAGE TO FAUNA 04 NARRATIVE DESCRIPTION	02 <input type="checkbox"/> OBSERVED (DATE _____)	<input type="checkbox"/> POTENTIAL	<input type="checkbox"/> ALLEGED		
NONE NOTED					
01 <input type="checkbox"/> L. CONTAMINATION OF FOOD CHAIN 04 NARRATIVE DESCRIPTION	02 <input type="checkbox"/> OBSERVED (DATE _____)	<input type="checkbox"/> POTENTIAL	<input type="checkbox"/> ALLEGED		
NONE NOTED					
01 <input checked="" type="checkbox"/> M. UNSTABLE CONTAINMENT OF WASTES (See Part 1, Section 3.2.2 for details)	02 <input type="checkbox"/> OBSERVED (DATE _____)	<input checked="" type="checkbox"/> POTENTIAL	<input type="checkbox"/> ALLEGED	03 POPULATION POTENTIALLY AFFECTED _____	04 NARRATIVE DESCRIPTION
Past occurrences of unexploded ordnance discovered and potential for future sitings.					
01 <input type="checkbox"/> N. DAMAGE TO OFF-SITE PROPERTY 04 NARRATIVE DESCRIPTION	02 <input type="checkbox"/> OBSERVED (DATE _____)	<input type="checkbox"/> POTENTIAL	<input type="checkbox"/> ALLEGED		
NONE NOTED					
01 <input type="checkbox"/> O. CONTAMINATION OF SEWERS, STORM DRAINS, WWTPS 04 NARRATIVE DESCRIPTION	02 <input type="checkbox"/> OBSERVED (DATE _____)	<input type="checkbox"/> POTENTIAL	<input type="checkbox"/> ALLEGED		
NONE NOTED					
01 <input type="checkbox"/> P. ILLEGAL/UNAUTHORIZED DUMPING 04 NARRATIVE DESCRIPTION	02 <input type="checkbox"/> OBSERVED (DATE _____)	<input type="checkbox"/> POTENTIAL	<input type="checkbox"/> ALLEGED		
NONE NOTED					
06 DESCRIPTION OF ANY OTHER KNOWN, POTENTIAL OR ALLEGED HAZARDS					
NONE NOTED					
III. TOTAL POPULATION POTENTIALLY AFFECTED: _____					
IV. COMMENTS					
Charleston District, Corps of Engineers maintains a file <sup>ic</sup> on the current information for the project. Point of contact is Wayne Bogan, CESAC-EN-PR, (803) 724-4366					
V. SOURCES OF INFORMATION (See Section 3.2.2 for details)					
Interviews, real estate information, site visits.					

PROJECT SUMMARY SHEET  
FOR  
DERP-FUDS OEW PROJECT I04SC001603  
CAMP CROFT ARMY TRAINING FACILITY  
SITE NO. I04SC001600  
19 SEPTEMBER 1991

PROJECT DESCRIPTION: The project consists of a 44 acre area "restricted to surface use only" when the site was released. The exact coordinates of the area are included in the project file. This area was used as an impact area during training in World War II for artillery, mortars, grenades, rifles, machine guns, and bazookas. There are other areas that have possible ordnance contamination. A golf course located next to the State Park removed large amounts of ordnance during excavation. Occurrences of public findings of ordnance have decreased in the past few years due to the restrictions on the use of metal detectors in the State Park. There have been occurrences in the past where as many as 80 grenades were found in one location. Interviews with the County Sheriff's Department have revealed that they expect to have as many as six to twelve pieces of ordnance removed per residential home during construction.

PROJECT ELIGIBILITY: The unexploded ordnance and potential of chemical weapons are a tremendous threat to the health and safety of the public located in the area and the environment.

POLICY CONSIDERATIONS: The ordnance located on the site occurs from former military training in the area with small arms, machine guns, mortars, and artillery.

PROPOSED PROJECT: The project consists of:

- a. locating and removing unexploded ordnance and chemical weaponry on the site, and
- b. restoring the site to background conditions.

RAC: Attached.

DISTRICT POC: Wayne Bogan, CESAC-EN-PR, (803) 724-4366.

727 4674

APPENDIX A  
RISK ASSESSMENT PROCEDURES FOR  
EXPLOSIVE ORDNANCE (EXO) OEW

Site Name Camp Croft Rater's Name Wayne Bogar  
 Site Location Spartanburg, SC Organization CE5AC-ED-PR  
 DERP Project # I04SC001603 RAC 1

EXO RISK ASSESSMENT:

This risk assessment procedure was developed in accordance with MIL-STD 882B and AR 385-10.

The EXO risk assessment is based upon documented evidence consisting of records searches, reports of Explosive Ordnance Disposal (EOD) detachment actions, and field observations, interviews, and measurements. These data are used to assess the risk involved based upon the hazards identified at the site. The risk assessment is composed of two factors, hazard severity and hazard probability.

Any field activities should be made with the assistance of qualified EOD personnel.

Part I. Hazard Severity. Hazard severity categories are defined to provide a qualitative measure of the worst credible mishap resulting from personnel exposure to various types and quantities of unexploded ordnance items.

TYPE OF ORDNANCE

A. Conventional Ordnance and Ammunition

	<u>YES</u> VALUE	<u>NO</u> VALUE	VALUE
Small Arms (.22 cal - .50 cal)	2	0	<u>2</u>
Medium/Large Caliber (20 mm and larger)	10	0	<u>10</u>
Bombs, Explosive	10	0	<u>0</u>
Bombs, Practice (w/spotting charges)	6	0	<u>0</u>
Grenades, Hand and Rifle, Explosive	10	0	<u>10</u>
Grenades, Practice (w/spotting charges)	6	0	<u>6</u>



	<u>YES</u> VALUE	<u>NO</u> VALUE	VALUE
Landmines, Explosive	10	0	<u>0</u>
Landmines, Practice (w/spotting charges)	6	0	<u>0</u>
Rockets, Guided Missiles, Explosive	10	0	<u>0</u>
Detonators, Blasting Caps	10	0	<u>0</u>
Demolition Charges	10	0	<u>0</u>
Conventional Ordnance and Ammunition Value (Maximum of 10).			<u>10</u>

B. Pyrotechnics

	<u>YES</u> VALUE	<u>NO</u> VALUE	VALUE
Any Munition Containing White Phosphorus or other Pyrophoric Material (i.e., Spontaneously Flammable)	10	0	<u>10</u>
Any Munition Containing a Flame or Incendiary Material (i.e., Napalm, Triethylaluminum Metal Incendiaries)	6	0	<u>0</u>
Military Flares	4	0	<u>0</u>
Pyrotechnics Value (Maximum of 10).			<u>10</u>

C. Bulk High Explosives (Bulk explosives not an integral part of conventional ordnance).

	<u>YES</u> VALUE	<u>NO</u> VALUE	VALUE
Primary or Initiating Explosives (Lead Styphnate, Lead Aride, Nitroglycerin, Mercury Aride, Mercury Fulminate, etc.)	10	0	<u>0</u>
Booster, Bursting or Fuse Explosives (PETN, Compositions A, B, C, Tetryl, TNT, RDX, HMX, HMX, Black Powder, etc.)	10	0	<u>0</u>

	<u>YES</u> VALUE	<u>NO</u> VALUE	VALUE
Military Dynamite	10	0	<u>0</u>
Less Sensitive Explosives (Ammonium Nitrate, Favier Explosives, etc.)	3	0	<u>0</u>
High Explosives Value (Maximum value of 10).			<u>0</u>

D. Propellants

	<u>YES</u> VALUE	<u>NO</u> VALUE	VALUE
Solid or Liquid Propellants	6	0	<u>0</u> <u>0</u>

E. Chemical Agents/Radiological Materials/Munitions

	<u>YES</u> VALUE	<u>NO</u> VALUE	VALUE
Radiological	25	0	<u>0</u>
Toxic Chemical Agents (Choking, Nerve, Blood, Blister)	25	0	<u>25</u>
Incapacitating Agent (BZ)	10	0	<u>0</u>
Riot Control and Miscellaneous (Vomiting, Tear, Chlorine, Mustard Simulant)	5	0	<u>0</u>
Any Munition Containing Smoke, Illumination, Signal Charge	4	0	<u>0</u>

Chemical Agents/Radiological Materials/Munitions Value (Maximum 25).

25

Total Ordnance and Explosive Waste Characteristics Value (Total =  
A + B + C + D + E with a Maximum value of 61).

45

TABLE 1  
HAZARD SEVERITY

Description	Category	Value
CATASTROPHIC	I	$\geq 21$
CRITICAL	II	$\geq 13 < 21$
MARGINAL	III	$\geq 5 < 13$
NEGLIGIBLE	IV	$< 5$

\* Apply Hazard Severity to Table 3.

Part II. Hazard Probability. The probability that a hazard has been or will be created due to the presence and other rated factors of explosive ordnance (EXO) on a formerly used DOD site.

AREA, EXTENT, ACCESSIBILITY OF CONTAMINATION

A. Locations of Contamination

	<u>YES</u> VALUE	<u>NO</u> VALUE	VALUE
Within Tanks, Pipes, Vessels or Other confined locations.	5	0	<u>0</u>
On the surface or within 3 feet.	5	0	<u>5</u>
Inside walls, ceilings, or other parts of Buildings or Structures.	4	0	<u>0</u>
Subsurface, greater than 3 feet in depth.	3	0	<u>3</u>

Value for location of EXO (Maximum Value of 5).

5

B. Distance to nearest inhabited locations or structures likely to be at risk from EXO site (roads, parks, playgrounds, and buildings).

<u>Distance to Nearest Target</u>	VALUE
Less than 1250 feet	(5)
1250 feet to 0.5 miles	4
0.5 miles to 1.0 mile	3
1.0 mile to 2.0 miles	2
2.0 miles to 5.0 miles	1
Over 5.0 miles	0

Distance to Persons Value (Maximum Value of 5).

5

C. Numbers and types of Buildings within a 2 mile radius measured from the hazardous area, not the installation boundary.

Number of Buildings	VALUE
0	0
1 to 10	1
11 to 50	2
51 to 100	3
101 to 250	④
251 or Over	5

Number of Buildings Value (Maximum Value of 5). 4

D. Types of Buildings

	VALUE
Educational, Child Care, etc.	5
Residential, Hospitals, Hotels, etc.	⑤
Commercial, Shopping Centers, etc.	⑤
Industrial Warehouse, etc.	4
Agricultural, Forestry, etc.	3
Detention, Correctional	2
Military	1
No Buildings	0

Types of Buildings Value (Maximum Value of 5). 5

E. Accessibility to site refers to the measures taken to limit access by humans or animals to ordnance and explosive wastes. Use the following guidance:

Barrier	Assigned Value
A 24-hour surveillance system (e.g., television monitoring or surveillance by guards or facility personnel) which continuously monitors and controls entry onto the facility;	0

or  
Barrier

Assigned Value

An artificial or natural barrier (e.g., a fence combined with a cliff), which completely surrounds the facility; and a means to control entry, at all times, through the gates or other entrances to the facility (e.g., an attendant, television monitors, locked entrances, or controlled roadway access to the facility).

0

Security guard, but no barrier

1

A barrier, (any kind of fence) but no separate means to control entry

2

Barriers do not completely surround the facility

3

No barrier or security system

5

Accessibility Value (Maximum Value of 5).

3

F. Site Dynamics - This deals with site conditions that are subject to change in the future, but may be stable at the present. Examples would be excessive soil erosion by beaches or streams, increasing land development that could reduce distances from the site to inhabited areas or otherwise increase accessibility.

VALUE

None Anticipated  
Expected

0

5

(Maximum Value of 5)

5

Total value for hazard probability.  
Sum of Values A through F.  
(Not to exceed 30). Apply this value to Hazard Probability Table 2 to determine Hazard Level.

27

TABLE 2

HAZARD PROBABILITY

Description	Level	Value
FREQUENT	A	≥27
PROBABLE	B	≥21 <27
OCCASIONAL	C	≥15 <21
REMOTE	D	≥ 8 <15
IMPROBABLE	E	<8

♦ Apply Hazard Probability to Table 3.

Part III. Risk Assessment. The risk assessment value for this site is determined using the following Table 3. Enter with the results of the hazard probability and hazard severity values.

TABLES 1 AND 2

HAZARD SEVERITY - I  
(from Table 1)

HAZARD PROBABILITY - A  
(from Table 2)

TABLE 3

Probability Level		FREQUENT A	PROBABLE B	OCCASIONAL C	REMOTE D	IMPROBABLE E
Severity Category:						
CATASTROPHIC	I	1	1	2	3	4
CRITICAL	II	1	2	3	4	5
MARGINAL	III	2	3	4	4	5
NEGLIGIBLE	IV	3	4	4	5	5

Note: The risk assessment code for EXO is not equivalent to the risk assessment code prescribed in AR 385-10:

RISK ASSESSMENT CODE (RAC)

- RAC 1     Imminent Hazard - Emergency action required to mitigate the hazard or protect personnel (i.e., Fencing, physical barrier, guards, etc.).
- RAC 2     Action required to mitigate hazard or protect personnel. Feasibility study is appropriate.
- RAC 3     Action required to evaluate potential threat to personnel. High priority Site Inspection is appropriate.
- RAC 4     Action required to evaluate potential threat to personnel. Site Inspection is appropriate.
- RAC 5     No action required.

Justification. In narrative form, summarize the documented evidence that supports this risk assessment.



101-101

DEPARTMENT OF THE ARMY  
Office of the Chief of Engineers  
Washington

Refer to file No. 604 Camp Croft, S. C. ENCL 2

20 December 1948

War Assets Administration  
Office of Real Estate Disposal  
Washington, D. C.

Dear Sir:

Reference is made to your letter of 10/17/48 and 1/27/49 in which you request  
that the title to the property be transferred to the War Assets Administration.

FOR THE CHIEF OF ENGINEERS

Sincerely yours,

W. H. HASTINGS  
Colonel, Corps of Engineers  
Assistant Chief of Engineers for Real Estate

GO 257

CERTIFICATE OF DEDUDDING

All lands within Camp Croft (All ranges) Spartanburg, S.C. have been given a careful visual inspection and have been cleared of all dangerous and/or explosive material as reasonably possible to discover. For the best of my knowledge and belief, this range will not require additional dedudding to render it safe for publication.

C/Sgt J. Wagner  
Sgt J. Wagner, Capt  
9800 S.W. - O.S. Det. #8  
Hornet/Boat Disposal Team

15 August 1984  
Morrison/614

MFR

Subject: Site Visit to Camp Croft, Spartanburg Co.,

In compliance with instructions contained in DR 335-1-1, 1 December 1980, report of site visit ~~at~~ by Stephen J. Morrison is made as follows:

a. Time of visit: 1200-1800, 12 August 1984.

b. Place: Croft State Park and surrounding lands that formerly made up ~~Camp~~ <sup>Camp</sup> Croft, a WW <sup>II</sup> training facility, Spartanburg County, S.C.

c. Purpose: To inspect a candidate site for work under the Environmental Restoration Defense Account (ERDA).

d. Persons Present:

Norman Mc Gee, Sav. Dist., Real Estate  
Rick Thomas, Fort Stewart, Savannah, Ga  
(Preparing Recapture Report on ~~Camp~~ <sup>Camp</sup> Croft)  
Ray Hayes, Superintendent, Croft State Park

e. Specific Matters Considered:

(1) Reference: MSC, HNDSD-PM, Huntsville Div, 201735Z JUL 84, SUBJ: ERO  
(2) Norman Mc Gee was to have provided maps of ~~the~~ <sup>the</sup> Camp Croft and Fort Moultrie installations. ~~The~~ <sup>maps</sup> ~~showed~~ <sup>showed</sup> no detail and ~~were~~ <sup>were</sup> of little use, either for identifying the <sup>areas of former</sup> military activity ~~at~~ (e.g., bombing ranges, storage sites, motor pool ~~at~~) or for locating boundaries of the 40-year-old ~~at~~ installations with reference to existing roads and properties.

(2) At 1300 we met Mr. Ray Hayes who has worked at Croft State Park for 14 years. ~~Camp~~ <sup>F-9</sup> ~~State~~ <sup>7,000</sup> Park was ~~given~~ <sup>given</sup> to the Sta ~~+~~

of the 19,044 acres that were <sup>transferred to State and</sup> ~~local ownership~~ <sup>after</sup> Camp Croft was closed. Mr. Hayes said he knew of no structures <sup>left by the Army</sup> inside the park that were considered hazardous or unsightly. Some structures had been converted to picnic shelters; other bunker-like structures were being used by Boy Scouts and others. Mr. Hayes knew of no toxic or other wastes that had been left on ~~the~~ lands given to the State and no incidents of contaminants leaking into surface or ground water, except from existing industrial sources outside of the ~~ERDA's~~ <sup>ERDA's</sup> responsibility. Mr. Hayes told of one incident when Boy Scouts had uncovered two cases of 50 mm machine gun ammunition, which ~~was~~ presumably had been buried <sup>prior to</sup> ~~the~~ transfer of the property to the State. He also told of finding "several" hand grenades scattered about a wooded area near an old foundation. He did not know if the grenades were "live" or merely deactivated training devices. We returned to the site but were unable to <sup>go to</sup> ~~find~~ any grenades on the ground surface. Mr. Hayes also said that when a nearby golf course was being built <sup>outside</sup> ~~the~~ state park) a great number of ~~unexploded~~ unexploded mortars and other ordnance ~~were~~ <sup>were</sup> uncovered and hauled away. He said similar items had been reported <sup>from time to time</sup> ~~on~~ former Camp Croft property now privately owned. Of the 7,000 acres in the park, Mr. Hayes ~~was~~ <sup>felt</sup> sure that there were no toxic wastes, unexploded ordnance, or hazardous structures above ground surface in the areas open to the public. If unexploded ordnance were present in other <sup>he said</sup> areas, it could create problems later if the park wished to expand into these areas. 44 acres in the park were restricted <sup>to surface use only</sup> in a quit claim deed ~~because~~ because of its previous use as an F-9 jet

and bazooka ranges," and the potential for "unexploded and dangerous bombs, shells, rockets, mines, and charges either upon or below the surface." This area has since been used on a number of occasions by the 391st Infantry for practice maneuvers and, according to Mr Hayes, it has been cleared of any surface hazards. On several occasions, personnel from Fort Jackson deactivated or exploded ordnance that had been found on park property.

(3) Mr Hayes said that much of the land which had been taken by the Government to create Camp Croft was ~~reacquired~~ <sup>reacquired</sup> by former owners. Other lands were ~~acquired~~ <sup>acquired</sup> by a Spartanburg County Foundation (SCF) which ~~sold~~ <sup>sold</sup> the land ~~to~~ <sup>to</sup> private companies or organizations. ~~SCF~~ ~~was~~ <sup>was</sup> asked to put together ~~the~~ <sup>the</sup> current tax maps of the area showing current owners and to make an overlay of the old Camp Croft boundaries at the same scale.

(4) We drove over the State Park property and much of the privately owned land. Several Army structures outside the park had been converted to ~~to~~ <sup>to</sup> business structures, ~~to~~ <sup>to</sup> apartments, or other uses. Mr Hayes had not heard of any problems on lands outside the park due to hazardous structures, debris, wastes, or ordnance left by the Army but recommended that we contact a Mr. Browley who had worked ~~with~~ <sup>with</sup> the SCF. He also said that a John Gossett <sup>of Spartanburg</sup> had been an officer at Camp Croft and a long time local resident, and could possibly tell us <sup>more</sup> about the operation of the camp, <sup>steps</sup> <sup>to</sup> remove ordnance, and any problems that may have occurred after the lands were transferred from DoD.

~~Mr.~~ Instructions issued or commitments made: Mr. McBean ~~SCF~~ ~~revisited~~ Mr. Morrison agreed to follow-up on the ~~two~~ <sup>two</sup> leads given by Mr Hayes and to begin preparation of the survey report requested.

reference e(1)

~~based on~~ <sup>brief</sup> field visit,

9. Camp Croft does not appear to have any problems ~~related~~ related to former OOD activities, with the <sup>possible</sup> exception of unexploded ordnance. Because ~~Croft~~ Croft State Park is used by a number of persons, including <sup>the Army,</sup> Scouts, ~~campers~~ campers, equestrians, hikers, and others that might dig below the ground ~~and~~ surface or stray into areas which have not been <sup>thoroughly</sup> cleared, there is a real potential for injury. Because the old camp covered over 19,000 acres and explosive devices may have been fired, <sup>or stored</sup> over a wide area, no quick scan or clean up program can be implemented. I recommend that the current survey report note the potential risk of unexploded ordnance <sup>at former Camp Croft property</sup> but address primarily the lack of <sup>any</sup> debris ~~problem~~ problem - which is what SAOPD's Dennis Barnett says is ~~the~~ Huntsville's <sup>concern</sup> main ~~concern~~ at this time. A plan of study - to be accomplished later would include ~~the~~

- (1) Obtaining a <sup>detailed</sup> map of the Camp Croft military facility, including the location of various <sup>ordnance</sup> activities.
- (2) Obtaining a map of current owners as described in paragraph e(2).
- (3) Interviews with most of <sup>the</sup> current owners whose <sup>properties</sup> ~~properties~~ <sup>are</sup> within any area formerly used for chemical storage, ordnance storage, or impact areas of artillery, mortars, grenades, bazookas, etc as determined by the detailed maps.
- (4) ~~Assessment of~~ <sup>description and cost</sup> estimates <sup>for</sup> scanning a limited number of areas, <sup>and</sup> removal of any unexploded ordnance <sup>hazardous</sup> or chemicals, and <sup>the</sup> disposal of same.

Mr. Cunningham, Trustee, Spartanburg Co. Foundation

Said that the Foundation acquired land from the Camp Croft property and resold it to various private organizations or to individuals. The Foundation tried to attract industry ~~that~~ <sup>that</sup> would provide local employment, create opportunities for recreation, establish residential housing, and otherwise sell the land to the public good. Some land was sold to individuals or development companies.

Mr. Cunningham said that his involvement with the Foundation did not extend back ~~to~~ many years, and he was not with the Foundation when it acquired the lands from the DoD. He was not sure how many acres were acquired by the Foundation. He said that to his knowledge there were no toxic chemicals, hazardous structures, debris, or unexploded ordnance on Foundation property, but he seemed to know less about the former Foundation properties than Mr. Hayes or Mr. Gosset. He suggested that we contact the Spartanburg Co. Sheriff's Office about the frequency of finding unexploded ordnance. He made vague reference to an old dump that was either on Hivann Co. property or on park property. He said that the dump ~~had~~ <sup>had</sup> been used in recent times and that he was not sure what the Army had put in the dump, if anything.

Mr. Browley, a former trustee of the Spartanburg Co. Foundation was called (8-21-84). He knew little about the original acquisition of property by the foundation or who the <sup>current</sup> major property owners were. He knew of no problems that had occurred on foundation owned property. He suggested that I call Mr. Stanley W. Converse who is still with the Founda

Mr. John E. Gosset, Sr. (818) 585 0668

8-20-84

Was maintenance engineer at Camp Coft during the war. Assisted with some construction and other work in the areas where explosives were used. He also worked on tearing down buildings after the war; many were simply pushed down and burned. He said that he had heard of other units that had thrown old drums (contents unknown), ordinance, and other materials down wells which were then closed up. Two or three wells which were not shown on the Army's maps were never closed, he said. At one time there were detailed maps of the individual artillery ranges, mortar ranges, rifle ranges, and other areas. He said Fort Jackson may have them, since they were called on occasion to come blow up mortars and other live ammunition discovered after the Camp's closing.

Mr. Gosset and his extended family acquired "about 1,100 Acres" of the former camp. He knew of no ~~chemicals~~ chemicals, unexploded ordinance, or other problems on their lands. He said that his son, John E. Gosset, Jr., also knew something about it.





8/23/84

## Fort Jackson, 48<sup>th</sup> EOD

Master Sergeant High, FTS 678-5126, Comm. 751-5126

23 Aug 84 Sgt. High returned my call after reviewing records of 48<sup>th</sup> EOD on Camp Croft area.

He said that over the past year they have not been called to Camp Croft (but County bomb disposal may have).

The year before last, they were called out to Camp Croft one or two times for ordnance disposal.

Prior to 2 years ago, the 48<sup>th</sup> EOD was going up to Camp Croft about once each month.

Most of the ordnance <sup>recovered by 48<sup>th</sup> EOD</sup> was 60-80 mm practice mortars (just steel - no charge); some ~~were~~ <sup>were</sup> practice mortars with fuses and spotting charges (could cause harm if exploded, but would not throw shrapnel over a wide area); a few were high explosives (very dangerous).

Based on the ordnance commonly used at similar training areas, there may also be <sup>Stokes</sup> mortars with white phosphorus, plasticized white phosphorus, or, possibly toxic gases.

When 48<sup>th</sup> EOD requested detailed information on the type of training, ordnance, and destruction or removal of hazardous materials, it was told through the Dept. of the Army to drop the request and that EOD would be contacted if they had a need to know.

There is a lot of political activity associated with the identification and removal of hazardous materials.

Suggested that we contact FORSCOM in Atlanta, Dep. Ops., 1-800-241-9135, Fort McPherson, to try to get more info on maps & former DOD use of Camp Cro.

Also the Ft. Jackson Museum Curator may have old maps or

# CONVERSATION RECORD

TIME AM

DATE 8 Oct 87

TYPE

 VISIT CONFERENCE TELEPHONE INCOMING OUTGOING

ROUTING

NAME/SYMBOL

INT

Location of Visit/Conference:

NAME OF PERSON(S) CONTACTED OR IN CONTACT WITH YOU

Jeff Beckner

ORGANIZATION (Office, dept., bureau, etc.)

Garraty &amp; Miller

TELEPHONE NO.

803  
649-3981

SUBJECT

Camp Croft - location of Water Wells

SUMMARY

Mr. Beckner was seeking information on the location of three water wells supposedly left when Camp Croft was closed. He said the wells were put in in the early 40's. I looked through our files and relayed the limited information which had been gathered by Steve Morrison in 1984. I suggested he call Jim Simpson, CESASRE and Don Duncan, DHEC, Columbia and George Milam or Laurie Brooks, DHEC, Greenville. Mr. Beckner also talked to Mr. Morrison about the area.

ACTION REQUIRED

NAME OF PERSON DOCUMENTING CONVERSATION

Robin Blackman

SIGNATURE

Robin L. Blackman

DATE

10/8/87



ACTION TAKEN

SIGNATURE

TITLE

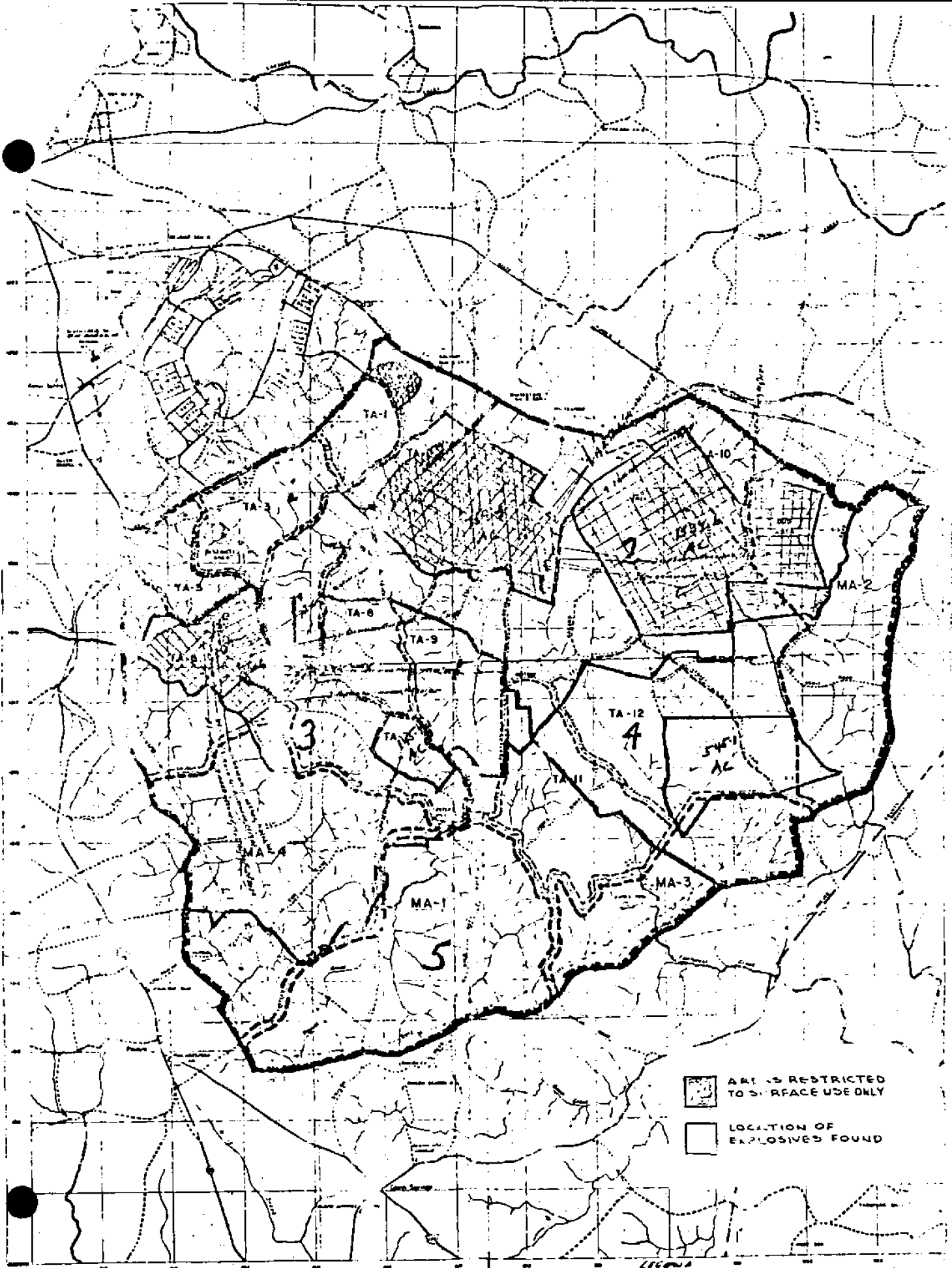
DATE



 AREAS RESTRICTED TO SURFACE USE ONLY  
 LOCATION OF EXPLOSIVES FOUND

1. This map is the property of the Army and is loaned to you for your use only. It is not to be distributed outside your organization.

2. This map is the property of the Army and is loaned to you for your use only. It is not to be distributed outside your organization.

3. This map is the property of the Army and is loaned to you for your use only. It is not to be distributed outside your organization.

**CAMP CROFT-13**  
**AND VICINITY**  
 BATTERY DEPARTMENT TRAINING CENTER



**DEPARTMENT OF THE ARMY**

SAVANNAH DISTRICT, CORPS OF ENGINEERS

P.O. BOX 800

SAVANNAH, GEORGIA 31402-0800

REPLY TO  
ATTENTION OF:

CESASRE-MM

31 May 1989

MEMORANDUM FOR: Commander, Charleston District, ATTN: CESAC-EN-PR  
(Blackman)

SUBJECT: Defense Environmental Restoration Program, Real Estate Information  
for Camp Croft, South Carolina

Enclosed is real estate information regarding Camp Croft, South Carolina.  
You had requested drawings only since the report has been completed.  
Please contact Sherry Oenbrink at (912) 944-5016, if you have any questions.

FOR THE COMMANDER:

Encl

A handwritten signature in cursive script, reading "Clyde E. Martin, Jr.", is written over the typed name.

CLYDE E. MARTIN, JR.  
Acting Chief, Management & Disposal  
Branch  
Real Estate Division

5 SEPT 90

JIM,

It looks as though time may be a little tight for the Camp Croft examination. In looking through Steve M's notes when he initially investigated the site, the format for procedures in reporting the findings were so different as a "new" site is essentially necessary to conform with the present format. Steve's notes are excellent in that they documented the problems of the time but fail to be as specific as the new format warrants. The site was ~19000 acres and has been extensively subdivided. The bulk (7000ac) is in holding as Croft State Park. Documented are accounts of all manner of explosives, some still active, disposed of by Ft. Jackson's 48<sup>th</sup> Explosive Ordnance Disposal<sup>(EOD)</sup> Unit. Most of the recovered ordnance was 60-80 mm practice mortars ~~which were~~ (have a sighting charge that could injure someone if exploded but do not throw shrapnel over a large area) but a few were actual high explosive shells. It is possible that shells containing white phosphorus, plasticized white phosphorus, and/or possibly toxic gas. I spoke with Steve and he said one person told him that they dumped a lot of the ordnance left over (after closing the camp) into a lake and at a later time several truck loads of ammo was removed. I spoke with Staff Sergeant Craig at Ft. Jax and he said they haven't been up there in the 2 years he has been with the EOD Unit.

F-14

Also, related in the file and in speaking with Steve, there are accounts (some presumed hearsay and 1 possibly confirmed) of dumping drums, ordnance, and other materials into the wells on the site. There is an account of a dump (landfill) with possible use after Army vacancy.

Spoke with Lt. Harold Hines of ~~Spargenberg~~ Spartanburg Sheriff's Dept. Bomb Disposal Unit and he said a lot of ordnance is regularly removed from the area-- primarily practice mortars and handgrenades. He took a carload of ordnance down to Ft. Jackson recently and one of the mortars was a real round. When an ordinary lot is cleared he expects 6-12 rounds to be uncovered. One time they found 80 live grenades stacked by a tree. He believes a long time ago (30 yr) a child was injured by a shell. He says you can still tell where the firing ranges were. He said there is suspicion that chemical weapons are "out there."

When ~~the~~ developing the area behind the hospital, crates of new, unused X-Ray machines were found. He heard that upon closing of the camp most everything was buried in pits and trenches.

CAMP CROFT CALLS RELATED TO ORDNANCE

PROJECT

5 SEPTEMBER 1990

Steve Holdeman

Lt. Harold Hines - Spartanburg Co. Sheriff

Bomb Disposal Unit

Tel #: (803) 596-2624  
2646

Lt. Hines said there is alot of ordnance out there-- confirms the practice mortars & grenades and live mortars and grenades. In just clearing a lot (ex. for house), he expects 6-12 pieces to be uncovered. He carries shells & grenades to Ft. Jax periodically. He related a story where, during practice maneuvers in the woods, they found 80 live grenades stacked next to a tree. Says you can still tell where the firing ranges are. Lt. Hines says he feels chemical weapons are present somewhere. When ~~exc~~<sup>exc</sup>avating the hospital numerous crates of new, unused X-Ray machines were found.

Staff Sergeant Craig - 48<sup>th</sup> Explosive Ordnance Disposal Unit

Fort Jackson, SC

COMM #: 803 751-5126 (FTS) 678-5126

Sgt. Craig said that in the 2 years he had been with the 48<sup>th</sup>, they had not received any calls for Disposal in that area. No one in the office could relate anything between Steve Morrison's 1984 visit and Sgt. Craig's 1988 recollection.

Richard Bishop  
450 Croft St. PK  
S 29302.

Park Superintendent Keith Windham - Croft State Park

OFFICE  
Tel #: (803) 585-1283 or SUPERINTENDANT RES. 585-0419

Grenade last winter and <sup>machine</sup> ~~gun~~ shells a few months ago, along with a mortar shell found by a person with a metal detector. The person was in the "back" area of the park several miles from the nearest recreation area (developed). There are fewer accounts now that the use of metal detectors is prohibited. Mr. Windham succeeded Mr. Hayes who is listed by Steve Morrison as the best local POC. He advised us to contact Joe Frank Watson - chief naturalist, to get approval for any investigations that might be done (803-734-0157).

Greg Henschel (formerly of the 48th) SLED, Narcotics Div.  
Columbia, SC tel #: 737-9000

When Camp Croft was going to be turned back to the County, they requested Ft. Jax's 48th ODU to decontaminate the area. The 48th needed to know what was fired so they would know what to expect. The higher up Army told them to drop the request because the info was classified. Rumor (unconfirmed) has it that chemical weapons were used and that is why the info was classified. When he was with the 48th, they removed 82mm practice mortars, practice grenades, and 2.36 and 3.5 (size?) rockets. Very little high explosive. He says the practice mortars pose little hazard. 50 yrs. of deterioration. **F-15** 11



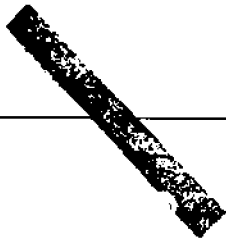

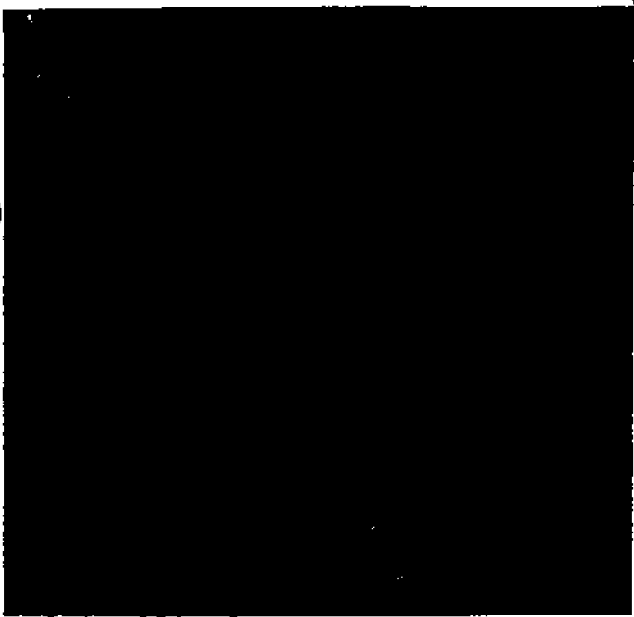

12305119648 8/12/84 POLAROID\*2  
S.C. Fish & Wildlife, leased to  
Located just north of Lake Ed-  
win Johnson. Used to store fertilizer

REC-APR 14 1985



12305119648 POLAROID\*2  
Quanset Hut, located at old rifle  
range. Area has been cleared and  
control burned. N. of Dairy Ridge Rd.

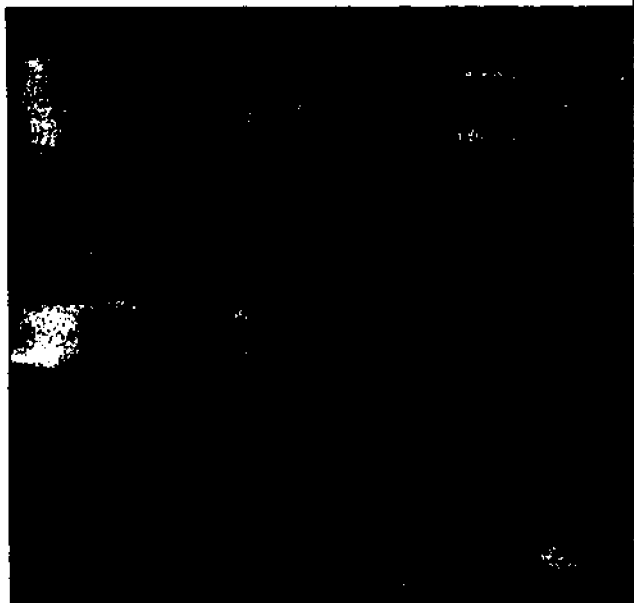

12305119648 POLAROID\*2  
Rifle range in background. Storage  
bunkers in foreground on left Also in  
background to left of lg oak trees

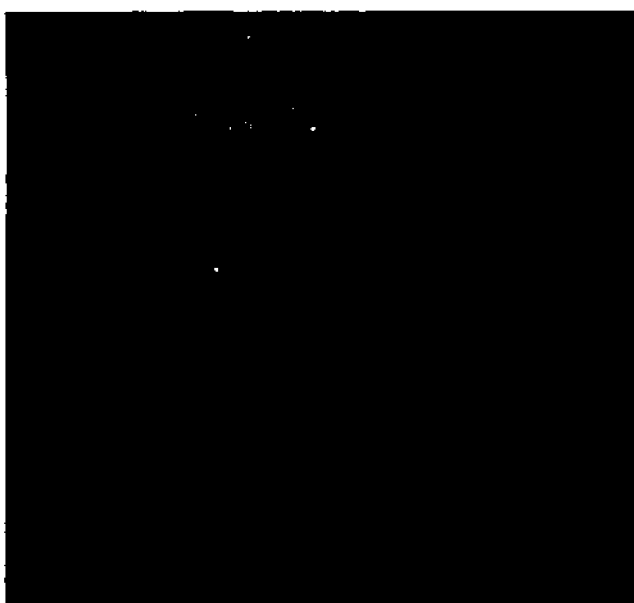

12305119648 POLAROID\*2  
Portion of former Camp Croft.  
Formerly motor pool according to RMB  
Hayes Now Union Camp Corp. 8/13/84

CAMP COPT

19 June 91

Interview of Keith Windom

shell found best winter in Whitestone Area.  
Wall up there

STATE PARK IS 7100 ACRES

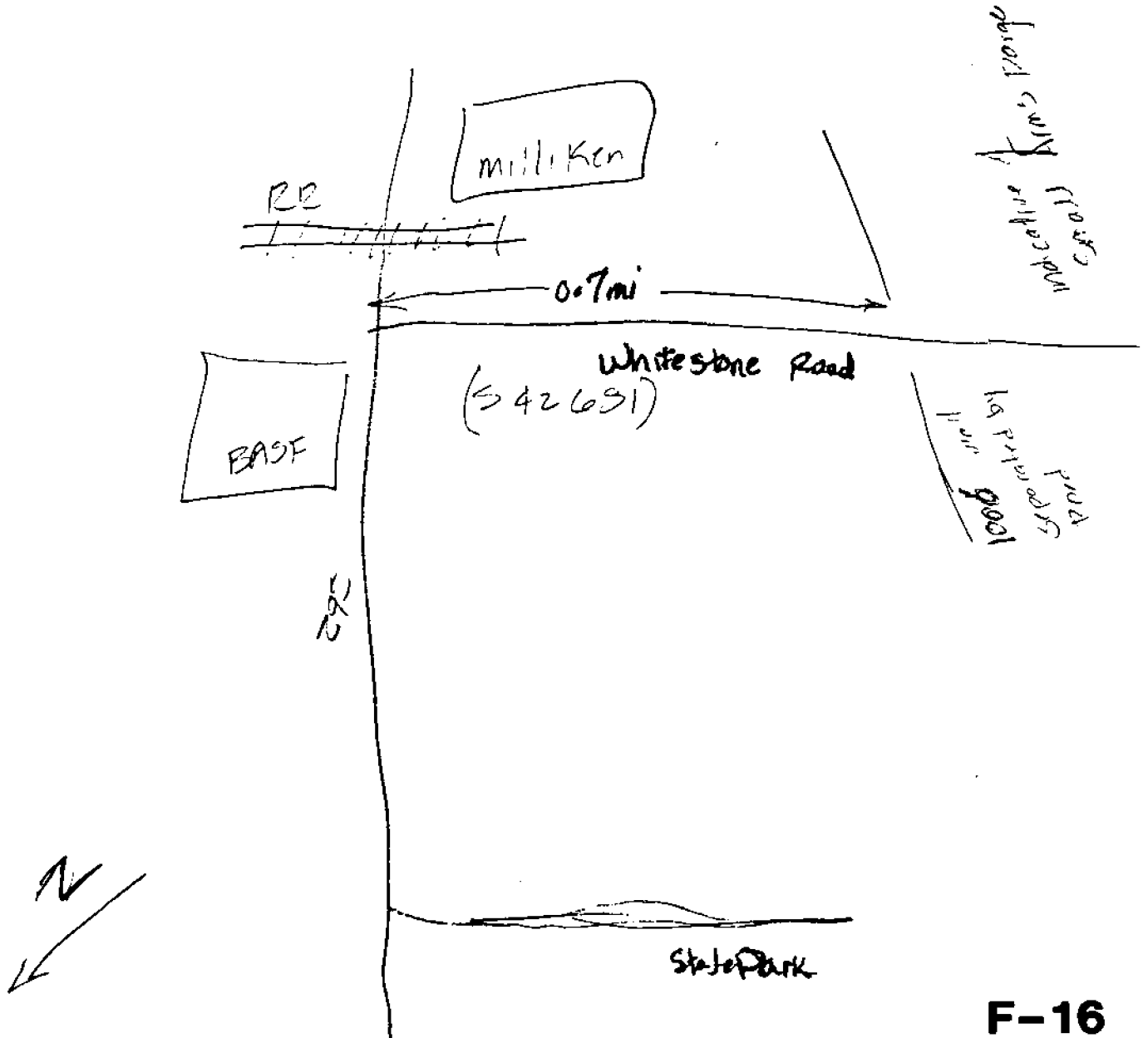

about 1000  
indicated  
CPT

1000  
1000  
good



↑  
169

CAMP CROFT

10456 001600

Looking down wall at small arms range.

19 JUNE 91

051807Z JUN 91

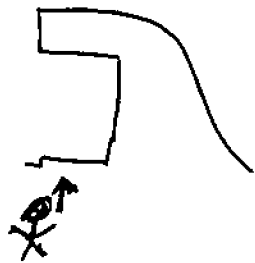

October 15, 1991

Planning Branch

SUBJECT: Croft State Park and Vicinity, formerly Camp Croft  
Army Training Facility, DERP-FUDS Site No. I04SC001600

Mr. Richard Bishop  
Park Superintendent, Croft State Park  
450 Croft State Park Road  
Spartanburg, SC 29302

Dear Mr. Bishop:

Enclosed is a fact sheet defining the Defense Environmental Restoration Program for Formerly Used Defense Sites (DERP-FUDS) and an Inventory Project Report (INPR). In the INPR we recommended that the site (Camp Croft) be examined for ordnance and hazardous waste. The INPR has been sent to our Division office for review, approval, and funding. The turnaround for approval is normally one year before we may begin construction. Due to the massive size of the original training facility, over 19,000 acres, Camp Croft will require a great deal of coordination and examination.

The actual work done at the project will depend upon the decision made at our Division office. We will closely coordinate our construction schedule for the removal of ordnance and hazardous waste with you and the surrounding community upon approval and funding of the project.

If you have any further questions, please contact Mr. Wayne Bogan at (803) 724-4366.

Sincerely,

BOGAN/4366  
A:016UPDAT

Joseph E. Keithley, Jr., P. E.  
Chief, Engineering and Planning  
Division

Enclosure

MEYER/EN-P

PREACHER/EN-PR

JACKSON/EN-P

KEITH: **F-17**

OCT 17 1991



Fred P. Brinkman, Executive Director

Division of State Parks  
Charles W. Harrison, Director  
(803) 734-0159  
FAX (803) 734-1017

October 29, 1991

Mr. Wayne Bogan  
Corps of Engineers  
P.O. Box 919  
Charleston, SC 29402-0919

Re: Croft State Park, formerly Camp Croft Army Training Facility,  
DERP-FUDS Site No. I04SC001600.

Dear Mr. Bogan:

We read with interest your fact sheet defining the Defense Environmental Restoration Program for formerly used defense sites. We look forward to hearing that this project has been approved and funded.

In the meantime we plan to request that the ordinance disposed unit at Ft. Jackson do a limited survey in an area where an unexploded mortar round was recently uncovered. If this action will present any problems for you and your study please let us know.

*Refer to note in  
log book 30 Oct 91*

*(WB)*

Sincerely,

Joe F. Watson  
Chief Naturalist  
Division of State Parks

PJFW643/klg

**F-18**

# CONVERSATION RECORD

TIME 30 Oct 91 DATE 2:00pm (1600)

TYPE  VISIT  CONFERENCE  TELEPHONE  
 INCOMING  OUTGOING

ROUTING	
NAME/SYMBOL	INT

Location of Visit/Conference:

NAME OF PERSON(S) CONTACTED OR IN CONTACT WITH YOU: Joe Watson  
 ORGANIZATION (Office, dept., bureau, etc.): Division of State Parks  
 TELEPHONE NO.: 803-734-0159

SUBJECT: Camp Croft. - Recently discovered mortar; live.

**SUMMARY**

Received letter from Joe Watson. I called and asked about the recently found mortar round ~~by~~. Two young men on the N.E. corner of the park where Hennington Rd. goes into the park property. The round was intact. The county contacted Ft. Jackson, EOD, who came and detonated the round. (803-751-5126) ~~The guy~~. He said he was going to write Ft. Jackson and request a limited survey of the area where the round was located. I said I would write them as well and would coordinate w/ the county.

ACTION REQUIRED: Call county + write letter to EOD + call EOD.

NAME OF PERSON DOCUMENTING CONVERSATION: Wayne Bogan, Jr.  
 SIGNATURE: Wayne Bogan, Jr.  
 DATE: 30 Oct 91

ACTION TAKEN

SIGNATURE: \_\_\_\_\_ TITLE: \_\_\_\_\_ DATE: \_\_\_\_\_



# CONVERSATION RECORD

TIME

2:45

DATE

30 Oct 91

TYPE

 VISIT CONFERENCE TELEPHONE INCOMING OUTGOING

ROUTING

NAME/SYMBOL

INT

Location of Visit/Conference:

NAME OF PERSON(S) CONTACTED OR IN CONTACT WITH YOU

Walt Perro

ORGANIZATION (Office, dept., bureau, etc.)

HND

TELEPHONE NO.

205-955-5142

SUBJECT

Mortar Round at Camp Croft.

SUMMARY

I asked Walt if there was a specific procedure for requesting that Ft. Jack EOD come and do a limited survey of the area. He agreed that a letter to them should be enough. I updated the situation on Camp Croft and explained what I was trying to do there.

ACTION REQUIRED

Send letter.

NAME OF PERSON DOCUMENTING CONVERSATION

Wayne Bogan, Jr.

SIGNATURE

Wayne Bogan, Jr.

DATE

30 Oct 91

ACTION TAKEN

SIGNATURE

TITLE

DATE

# CONVERSATION RECORD

TIME  
2:30

DATE  
30 Oct 91

TYPE

VISIT

CONFERENCE

TELEPHONE

INCOMING

OUTGOING

ROUTING

NAME/SYMBOL	INT

Location of Visit/Conference:

NAME OF PERSON(S) CONTACTED OR IN CONTACT WITH YOU

ORGANIZATION (Office, dept., bureau, etc.)

TELEPHONE NO.

?

FT. Jack, EOD

803-751-5126

SUBJECT

Mortar round at ~~FT Jackson~~ Camp Croft

SUMMARY

I talked w/ the fella who took the call from the county. He said they traveled to Camp Croft and detonated the round. He walked a 500m x 200m area around the location of the mortar and found several relics such as fuses, casings, etc. I suggested the limited survey of the area and he said they were waiting on an official letter requesting the survey. I said I would get in touch w/ the county and one of us would send out a letter. He suggested writing to:

Cpt. William Schesser

48th Ordnance Department, EOD.

Ft Jackson, SC 29207

ACTION REQUIRED

Call County - write letter

NAME OF PERSON DOCUMENTING CONVERSATION

SIGNATURE

DATE

Wayne Bogan, Jr.

Wayne Bogan, Jr.

30 Oct 91

ACTION TAKEN

SIGNATURE

TITLE

DATE

ORDNANCE AND EXPLOSIVE WASTE  
ARCHIVES SEARCH REPORT  
FOR  
FORMER CAMP CROFT ARMY TRAINING FACILITY  
SPARTANBURG, SOUTH CAROLINA  
PROJECT NUMBER I04SC001603

APPENDIX G

REAL ESTATE DOCUMENTS

APPENDIX G

REAL ESTATE DOCUMENTS

Table of Contents

- 
- G-1 Property Plat of Reservation, Camp Croft, SC (Showing location of individual tracts), June 17, 1941, see Document L-12
- G-2 Drawing No. 1021-7 (four sheets), War Department, Office of the Division Engineer, South Atlantic Division, Camp Croft Military Reservation, January 15, 1946 , see Document L-13
- G-3 Quitclaim, South Carolina, former Camp Croft, 26 May 1949

see Appendix L-12

see Appendix L-13

ROUTING AND TRANSMITTAL SLIP

Date 8 AUG 64

TO: (Name, office symbol, room number, building, Agency/Post)

1 SACEN-E (Steve MORRISON)

Initials

Date

Action	File	Note and Return
Approval	For Clearance	For Conversation
As Requested	For Correction	Prepare Reply
Circulate	For Your Information	See Me
Comment	Investigate	Signature
Coordination	Justify	

REMARKS

Re: E.R.D.A. site, Camp Croft

Note 44 acre restricted use area.

DO NOT use this form as a RECORD of approvals, concurrences, disposals, clearances, and similar actions

FROM: (Name, org. symbol, Agency/Post)

Room No.—Bldg.

RE-MCA (McGEE)

Phone No. 5202

OPTIONAL FORM 41 (Rev. 7-76)  
Prescribed by GSA  
FPMR (41 CFR) 101-11.206

300m (GALVIA)

WHEREAS, the Department of the Army, in its capacity as the primary authority for the regulation of...

WHEREAS, the Department of the Army, in its capacity as the primary authority for the regulation of...

WHEREAS, the Department of the Army, in its capacity as the primary authority for the regulation of...

WHEREAS, the Department of the Army, in its capacity as the primary authority for the regulation of...

WHEREAS, the Department of the Army, in its capacity as the primary authority for the regulation of...

Begin at the intersection of...  
 1. 1/2 mile from pin 1  
 2. 1/2 mile from pin 1  
 3. 1/2 mile from pin 1  
 4. 1/2 mile from pin 1  
 5. 1/2 mile from pin 1  
 6. 1/2 mile from pin 1  
 7. 1/2 mile from pin 1  
 8. 1/2 mile from pin 1  
 9. 1/2 mile from pin 1  
 10. 1/2 mile from pin 1  
 11. 1/2 mile from pin 1  
 12. 1/2 mile from pin 1  
 13. 1/2 mile from pin 1  
 14. 1/2 mile from pin 1  
 15. 1/2 mile from pin 1  
 16. 1/2 mile from pin 1  
 17. 1/2 mile from pin 1  
 18. 1/2 mile from pin 1  
 19. 1/2 mile from pin 1  
 20. 1/2 mile from pin 1  
 21. 1/2 mile from pin 1  
 22. 1/2 mile from pin 1  
 23. 1/2 mile from pin 1  
 24. 1/2 mile from pin 1  
 25. 1/2 mile from pin 1  
 26. 1/2 mile from pin 1  
 27. 1/2 mile from pin 1  
 28. 1/2 mile from pin 1  
 29. 1/2 mile from pin 1  
 30. 1/2 mile from pin 1  
 31. 1/2 mile from pin 1  
 32. 1/2 mile from pin 1  
 33. 1/2 mile from pin 1  
 34. 1/2 mile from pin 1  
 35. 1/2 mile from pin 1  
 36. 1/2 mile from pin 1  
 37. 1/2 mile from pin 1  
 38. 1/2 mile from pin 1  
 39. 1/2 mile from pin 1  
 40. 1/2 mile from pin 1  
 41. 1/2 mile from pin 1  
 42. 1/2 mile from pin 1  
 43. 1/2 mile from pin 1  
 44. 1/2 mile from pin 1  
 45. 1/2 mile from pin 1  
 46. 1/2 mile from pin 1  
 47. 1/2 mile from pin 1  
 48. 1/2 mile from pin 1  
 49. 1/2 mile from pin 1  
 50. 1/2 mile from pin 1  
 51. 1/2 mile from pin 1  
 52. 1/2 mile from pin 1  
 53. 1/2 mile from pin 1  
 54. 1/2 mile from pin 1  
 55. 1/2 mile from pin 1  
 56. 1/2 mile from pin 1  
 57. 1/2 mile from pin 1  
 58. 1/2 mile from pin 1  
 59. 1/2 mile from pin 1  
 60. 1/2 mile from pin 1  
 61. 1/2 mile from pin 1  
 62. 1/2 mile from pin 1  
 63. 1/2 mile from pin 1  
 64. 1/2 mile from pin 1  
 65. 1/2 mile from pin 1  
 66. 1/2 mile from pin 1  
 67. 1/2 mile from pin 1  
 68. 1/2 mile from pin 1  
 69. 1/2 mile from pin 1  
 70. 1/2 mile from pin 1  
 71. 1/2 mile from pin 1  
 72. 1/2 mile from pin 1  
 73. 1/2 mile from pin 1  
 74. 1/2 mile from pin 1  
 75. 1/2 mile from pin 1  
 76. 1/2 mile from pin 1  
 77. 1/2 mile from pin 1  
 78. 1/2 mile from pin 1  
 79. 1/2 mile from pin 1  
 80. 1/2 mile from pin 1  
 81. 1/2 mile from pin 1  
 82. 1/2 mile from pin 1  
 83. 1/2 mile from pin 1  
 84. 1/2 mile from pin 1  
 85. 1/2 mile from pin 1  
 86. 1/2 mile from pin 1  
 87. 1/2 mile from pin 1  
 88. 1/2 mile from pin 1  
 89. 1/2 mile from pin 1  
 90. 1/2 mile from pin 1  
 91. 1/2 mile from pin 1  
 92. 1/2 mile from pin 1  
 93. 1/2 mile from pin 1  
 94. 1/2 mile from pin 1  
 95. 1/2 mile from pin 1  
 96. 1/2 mile from pin 1  
 97. 1/2 mile from pin 1  
 98. 1/2 mile from pin 1  
 99. 1/2 mile from pin 1  
 100. 1/2 mile from pin 1

WHEREAS, the said recommendations are contained in a letter from the Office of the Chief of Engineers, Department of the Army, to the War Assets Administration, dated December 20, 1948, a copy of the pertinent portions of which is attached hereto and made a part hereof, and

WHEREAS, the Department of the Army has made certain other recommendations pertaining to the use of the lands hereby conveyed and hereinafter described, except the portions of said lands restricted to surface use only as hereinafter described, may be necessary and

*Campdraft*

**SOUTH CAROLINA**

**CONCEALMENT DEED**

**KNOW ALL MEN BY THESE PRESENTS THAT:**

WHEREAS the property hereinafter described, was declared surplus for the needs of the United States of America pursuant to the provisions of the Surplus Property Act of 1946 (50 Stat. 765) as amended, and War Assets Administration Regulations No. 1, as amended (31 CFR 108) and;

WHEREAS the property hereinafter described, was formerly used by the Department of the Army as an impact area of artillery, mortar, grenade, rifle, machine gun, and barbed wire, and;

WHEREAS such property was subjected to contamination by the introduction of unexploded and dangerous bombs, shells, rockets, mines, and charges, either upon or below the surface thereof; and;

WHEREAS the GRANTOR, by and through the Corps of Engineers, Department of the Army, has caused the property to be inspected and has decontaminated the same to the extent deemed reasonably necessary in the opinion of the GRANTOR, and consistent with economic limitations, and has made certain recommendations pertaining to the uses to which the land may be devoted; and;

WHEREAS the Department of the Army has recommended that the following described portion of said property be restricted to surface use only:

Beginning at the north corner of tract 701 at an iron pin on the east bank of County Road and thence S 52-56° E 1183.96 ft to an iron pin thence S 36-21-43° W 380.19 ft to an iron pin thence S 36-16-15° W 508.96 ft to an iron pin thence S 37-22-00° W 611.59 ft to an iron pin in the east line of a branch thence S 39-50-15° W 207.15 ft to an iron pin thence S 10-02-00° W 172.10 ft to an iron pin thence S 37-19-30° W 515.71 ft to an iron pin thence S 37-19-45° W 123.91 ft to an iron pin thence S 37-23-15° W 137.81 ft thence S 37-25-30° W 497.60 ft to an iron pin thence S 17-09-30° W 165.15 ft to an iron pin thence S 16-59-00° W 305.57 ft to an iron pin thence S 56-05-15° W 372.18 ft to an iron pin thence S 56-19-30° W 1118.56 ft to an iron pin on the east line of the County Road thence along the east line of the road S 19-47-45° E 694.00 ft to an iron pin thence S 30-11-45° E 1108.70 ft to an iron pin thence S 32-41-47° E 592.15 ft to an iron pin thence S 38-17-00° E 1060.59 ft to an iron pin thence S 52-25-00° E 1257 ft to an iron pin thence S 15-16-00° E 527 ft more or less to an iron pin the point of beginning, containing 114.00 ± more or less ac.

WHEREAS the said recommendations are contained in a letter from the Office of the Chief of Engineers, Department of the Army to the War Assets Administration, dated December 20, 1948, a copy of the pertinent portions of which is attached hereto and made a part hereof; and;

WHEREAS the Department of the Army has made certain other recommendations pertaining to the use of individual portions of the land hereby conveyed and hereinafter described, except that portion of said land restricted to surface use only as hereinafter described, may be devoted to and;



WHEREAS, the said recommendations are contained in a certificate, a copy of which is attached hereto, and under part hereof; and

WHEREAS, the GRANTOR, by attaching such certificate does not intend, nor shall it be construed to have made, any representation or warranties pertaining to the condition of the land; and

WHEREAS, the GRANTOR hereinafter designated, has advised the desire to purchase such property with full knowledge of, and notwithstanding the foregoing;

NOW, THEREFORE, the UNITED STATES OF AMERICA, acting by and through the Federal Farm Mortgage Corporation, and its pursuant to the power and authority contained in the provisions of the Surplus Property Act of 1946 (58 Stat. 765), as amended, and particularly by Public Law 616, 80th Congress, approved June 10, 1948, Regulation No. 17 of the Surplus Property Board (101 F.R. 376), a Order of the Secretary of Agriculture dated April 26, 1947 (101 F.R. 1447) and Order of the Government of the Farm Credit Administration dated April 26, 1947 (101 F.R. 1461), GRANTOR, in consideration of the premises, the continuous use and maintenance of the premises by the SOUTH CAROLINA STATE COLLEGE OF FORESTRY, GRANTOR, for scientific, public and public recreational purposes, the observance and performance of the covenants, conditions, restrictions and reversions hereinafter contained, and in consideration of the payment of the sum of thirty-nine thousand five hundred and 00/100 Dollars (\$39,500.00) in hand paid by the GRANTOR, receipt of which is hereby acknowledged, has granted, bargained, sold, released and forever quitclaimed, and by these presents does grant, bargain, sell, release and forever quitclaim, without any warranties, express or implied, recourse or liability whatsoever, even as to the restitution of the purchase price, to the GRANTOR, its successors and assigns, subject to the exception and reservation of certain materials and rights hereinafter set out, all the right, title, interest and estate of the GRANTOR in and to the following described property situated lying and being in the County of Spartanburg, State of South Carolina, to-wit:

Beginning at concrete monument on the south side of old State Highway No. 74 at the northeast corner of Spartanburg County Foundation property and road thence with the Foundation as lines S. 28-53 W. 362.85', S. 25-42 W. 382.05', S. 21-39 W. 441.58', S. 14-25 W. 658.66', S. 11-46 W. 636.22', S. 05-03 W. 167.13', S. 00-15 N. 301.22', S. 11-18 E. 303.22', S. 17-44 W. 100.15', S. 10-46 W. 81.65', S. 19-15 W. 250.45', S. 33-01 W. 127.18', S. 70-02 W. 163.05', S. 80-16 W. 615.45', S. 77-11 W. 313.88', S. 57-08 W. 409.17', S. 49-54 W. 122.20', S. 15-24 W. 802.18', S. 16-37 W. 697.60', S. 50-48 W. 277.44', S. 11-13 E. 181.18', S. 50-02 E. 949.95', S. 67-30 E. 238.30', S. 48-05 W. 533.80', S. 00-27 W. 409.73', S. 21-11 E. 208.91', S. 10-27 E. 111.08', S. 37-33 W. 1108.93', S. 32-09 W. 566.91', S. 57-50 E. 300.00', S. 22-41 W. 194.50', S. 07-37 W. 363.90', S. 19-21 E. 322.20', S. 32-47 E. 678.20', S. 57-13 W. 140.27', thence leaving the line of the Foundation property and road S. 81-40 W. 1107', S. 10-35 E. 190', S. 76-15 W. 632', S. 77-12 W. 57', S. 08-55 E. 271.6', S. 09-25 E. 866', S. 08-40 E. 980', S. 75-20 W. 993', S. 08-40 E. 2105', S. 18-02 W. 120', S. 48-00 W. 147.55', S. 10-00 W. 1623', S. 46-30 W. 760', S. 09-21 E. 217.5', to U.S. Highway 176, thence along the highway S. 33-30 E. 1551', thence leaving the highway S. 06-58 E. 1404.9', S. 02-25 E. 757', S. 67-05 W. 150', S. 08-10 E. 238', S. 01-45 W. 590', to U.S. Highway 176, S. 07-30 E. 155.5', S. 02-11 W. 230', S. 02-11 W. 912.5', S. 26-40 W. 517.4', S. 30-35 W. 225.3', thence leaving the highway S. 44-17 E. 273.9', S. 10-06 W. 303.2', S. 00-46 E. 188.3', S. 13-40 E. 138.6', S. 15-08 E. 269', S. 05-23 W. 280', S. 03-02 W. 411.16', S. 06-53 E. 127.2', S. 03-18 E. 520.64', S. 23-33 E. 351.2', S. 33-41 E. 535', S. 29-17 E. 198.9', S. 23-54 E. 311.3', S. 16-19 E. 278', S. 13-58 E. 570', S. 12-10 E. 157', S. 50-09 E. 382', S. 49-14 E. 300.3', S. 51-31 E. 175.0', S. 50-08 E. 257.3', S. 18-42 E. 208.9', S. 21-30 E. 244.8', S. 45-03 E. 320', S. 18-41 E. 319', S. 63-25 E. 185', S. 63-25 E. 518', S. 63-25 E. 167', S. 25-40 E. 1600', S. 25-40 E. 1536', S. 45-45 E. 1342', S. 45-45 E. 898'

N 75-55 E 350' W 18-10 E 214' N 75-10 E 156' N 07-00 W 201' N  
 N 14-50 E 195' N 148-35 E 895' N 52-40 E 1287' N 148-50 E 610' N  
 N 11-00 E 139' N 15-15 E 910' N 11-50 W 611' N 00-35 E 252' N  
 N 12-00 E 600' N 05-15 E 1571' N 25-30 W 4000' N 77-50 W 195' N  
 N 11-15 E 240' N 72-05 E 120' N 11-15 E 347' N 74-50 E 368' N  
 N 30-35 E 215' N 07-10 E 530' N 62-00 E 310' N 75-45 E 513' N  
 N 10-10 E 400' N 72-40 E 971' N 57-00 E 550' N 75-00 E 252' N  
 N 01-00 E 435' N 75-20 E 800' N 74-10 E 540' N 06-00 W 362' N  
 N 17-45 E 330' N 10-20 E 290' N 24-40 E 162' N 59-15 W 1126' N  
 N 11-55 E 207' N 26-35 E 940' N 15-55 W 316' N 22-35 E 239' N  
 N 74-00 E 965' N 01-10 E 1100' N 12-55 E 58' N 00-15 E 1120' N  
 N 00-15 E 215' N 25-15 E 1411' N 61-30 W 1035' N 35-10 W 201' N  
 N 14-00 W 180' N 26-35 W 220' N 26-35 W 207' N 65-30 W 710' N  
 N 00-30 W 85' N 60-10 W 150' N 66-10 W 1043' N 06-15 W 760' N  
 N 70-30 W 97' N 74-30 W 800' N 06-05 W 755' N 80-45 W 290' N  
 N 07-10 E 250' N 00-00 W 955' N 21-05 W 352' N 24-55 W 540' N  
 N 26-55 E 600' N 62-30 W 1150' N 05-45 E 614' N 13-15 E 975' N  
 N 01-35 W 910' N 18-30 E 1975' N 14-30 E 265' N 15-35 W 660' N  
 N 12-10 W 125' N 14-30 W 590' N 14-30 W 920' N 37-15 W 250' N  
 N 26-15 W 145' N 52-30 W 306' N 29-35 W 179' N 04-14 W 724' N  
 N 52-30 W 1070' N 15-14 W 521' N 19-20 W 125' N 10-14 W 1060' N  
 N 32-05 W 200' N 32-05 W 717' N 12-12 W 593' N 80-12 W 420' N  
 N 38-10 W 101' N 20-15 W 785' N 15-37 W 1189' N 13-13 W  
 1617' N 27-17 W 1016' N 61-55 E 1264' N 80-25 W 289' N  
 N 07-20 E 515' N 01-15 E 4051' N 07-17 W 152' N 25-10 E  
 260' N 25-00 E 350' N 71-10 E 162' N 59-15 E 130' N 45-00 E  
 195' N 72-50 E 335' N 20-30 W 700' N 65-15 E 37' N 10-00 E  
 290' N 61-30 W 600' N 20-30 W 1595' N 67-15 E 505' N 71-13 E  
 255' N 01-21 E 502' N 76-10 E 156' N 79-22 E 157' N 51-19 E  
 07' N 14-30 E 637' N 11-15 E 767' N 26-30 W 435' N 61-00 E  
 290' N 32-30 E 157' N 50-30 E 204' N 74-00 E 100' N 52-30 E  
 175' N 13-15 E 300' N 28-00 E 200' N 05-15 E 207' N 08-20 E  
 170' N 01-00 E 190' N 34-45 W 264' N 11-00 E 970' N 50-55 W  
 165' N 60-06 W 225' N 60-06 W 375' N 63-06 E 158' N 60-06 W 62' N  
 to the point of beginning, containing 7088.08 acres & more or less,  
 being tracts 9, 17, 30, 31, 32, 14, 50, 51 and 53, 52, 54, 55, 56,  
 57, 58, 59, 60, 61, 62, 63, 64, 65, 66, 67,  
 68, 69, 70, 71, 72, 73, 74, 75, 149, 160, 171, 172, 173, 174, 175, 176, 177, 178, 179, 180, 181, 182,  
 183, 184, 185, 186, 187, 188, 189, 190, 191, 192, 193, 194, 195, 196, 197, 198, 199, 200, 201, 202, 203, 204, 205, 206, 207, 208, 209, 210, 211, 212, 213, 214, 215, 216, 217, 218, 219, 220, 221, 222, 223, 224, 225, 226, 227, 228, 229, 230, 231, 232, 233, 234, 235, 236, 237, 238, 239, 240, 241, 242, 243, 244, 245, 246, 247, 248, 249, 250, 251, 252, 253, 254, 255, 256, 257, 258, 259, 260, 261, 262, 263, 264, 265, 266, 267, 268, 269, 270, 271, 272, 273, 274, 275, 276, 277, 278, 279, 280, 281, 282, 283, 284, 285, 286, 287, 288, 289, 290, 291, 292, 293, 294, 295, 296, 297, 298, 299, 300, 301, 302, 303, 304, 305, 306, 307, 308, 309, 310, 311, 312, 313, 314, 315, 316, 317, 318, 319, 320, 321, 322, 323, 324, 325, 326, 327, 328, 329, 330, 331, 332, 333, 334, 335, 336, 337, 338, 339, 340, 341, 342, 343, 344, 345, 346, 347, 348, 349, 350, 351, 352, 353, 354, 355, 356, 357, 358, 359, 360, 361, 362, 363, 364, 365, 366, 367, 368, 369, 370, 371, 372, 373, 374, 375, 376, 377, 378, 379, 380, 381, 382, 383, 384, 385, 386, 387, 388, 389, 390, 391, 392, 393, 394, 395, 396, 397, 398, 399, 400, 401, 402, 403, 404, 405, 406, 407, 408, 409, 410, 411, 412, 413, 414, 415, 416, 417, 418, 419, 420, 421, 422, 423, 424, 425, 426, 427, 428, 429, 430, 431, 432, 433, 434, 435, 436, 437, 438, 439, 440, 441, 442, 443, 444, 445, 446, 447, 448, 449, 450, 451, 452, 453, 454, 455, 456, 457, 458, 459, 460, 461, 462, 463, 464, 465, 466, 467, 468, 469, 470, 471, 472, 473, 474, 475, 476, 477, 478, 479, 480, 481, 482, 483, 484, 485, 486, 487, 488, 489, 490, 491, 492, 493, 494, 495, 496, 497, 498, 499, 500, 501, 502, 503, 504, 505, 506, 507, 508, 509, 510, 511, 512, 513, 514, 515, 516, 517, 518, 519, 520, 521, 522, 523, 524, 525, 526, 527, 528, 529, 530, 531, 532, 533, 534, 535, 536, 537, 538, 539, 540, 541, 542, 543, 544, 545, 546, 547, 548, 549, 550, 551, 552, 553, 554, 555, 556, 557, 558, 559, 560, 561, 562, 563, 564, 565, 566, 567, 568, 569, 570, 571, 572, 573, 574, 575, 576, 577, 578, 579, 580, 581, 582, 583, 584, 585, 586, 587, 588, 589, 590, 591, 592, 593, 594, 595, 596, 597, 598, 599, 600, 601, 602, 603, 604, 605, 606, 607, 608, 609, 610, 611, 612, 613, 614, 615, 616, 617, 618, 619, 620, 621, 622, 623, 624, 625, 626, 627, 628, 629, 630, 631, 632, 633, 634, 635, 636, 637, 638, 639, 640, 641, 642, 643, 644, 645, 646, 647, 648, 649, 650, 651, 652, 653, 654, 655, 656, 657, 658, 659, 660, 661, 662, 663, 664, 665, 666, 667, 668, 669, 670, 671, 672, 673, 674, 675, 676, 677, 678, 679, 680, 681, 682, 683, 684, 685, 686, 687, 688, 689, 690, 691, 692, 693, 694, 695, 696, 697, 698, 699, 700, 701, 702, 703, 704, 705, 706, 707, 708, 709, 710, 711, 712, 713, 714, 715, 716, 717, 718, 719, 720, 721, 722, 723, 724, 725, 726, 727, 728, 729, 730, 731, 732, 733, 734, 735, 736, 737, 738, 739, 740, 741, 742, 743, 744, 745, 746, 747, 748, 749, 750, 751, 752, 753, 754, 755, 756, 757, 758, 759, 760, 761, 762, 763, 764, 765, 766, 767, 768, 769, 770, 771, 772, 773, 774, 775, 776, 777, 778, 779, 780, 781, 782, 783, 784, 785, 786, 787, 788, 789, 790, 791, 792, 793, 794, 795, 796, 797, 798, 799, 800, 801, 802, 803, 804, 805, 806, 807, 808, 809, 810, 811, 812, 813, 814, 815, 816, 817, 818, 819, 820, 821, 822, 823, 824, 825, 826, 827, 828, 829, 830, 831, 832, 833, 834, 835, 836, 837, 838, 839, 840, 841, 842, 843, 844, 845, 846, 847, 848, 849, 850, 851, 852, 853, 854, 855, 856, 857, 858, 859, 860, 861, 862, 863, 864, 865, 866, 867, 868, 869, 870, 871, 872, 873, 874, 875, 876, 877, 878, 879, 880, 881, 882, 883, 884, 885, 886, 887, 888, 889, 890, 891, 892, 893, 894, 895, 896, 897, 898, 899, 900, 901, 902, 903, 904, 905, 906, 907, 908, 909, 910, 911, 912, 913, 914, 915, 916, 917, 918, 919, 920, 921, 922, 923, 924, 925, 926, 927, 928, 929, 930, 931, 932, 933, 934, 935, 936, 937, 938, 939, 940, 941, 942, 943, 944, 945, 946, 947, 948, 949, 950, 951, 952, 953, 954, 955, 956, 957, 958, 959, 960, 961, 962, 963, 964, 965, 966, 967, 968, 969, 970, 971, 972, 973, 974, 975, 976, 977, 978, 979, 980, 981, 982, 983, 984, 985, 986, 987, 988, 989, 990, 991, 992, 993, 994, 995, 996, 997, 998, 999, 1000, 1001, 1002, 1003, 1004, 1005, 1006, 1007, 1008, 1009, 1010, 1011, 1012, 1013, 1014, 1015, 1016, 1017, 1018, 1019, 1020, 1021, 1022, 1023, 1024, 1025, 1026, 1027, 1028, 1029, 1030, 1031, 1032, 1033, 1034, 1035, 1036, 1037, 1038, 1039, 1040, 1041, 1042, 1043, 1044, 1045, 1046, 1047, 1048, 1049, 1050, 1051, 1052, 1053, 1054, 1055, 1056, 1057, 1058, 1059, 1060, 1061, 1062, 1063, 1064, 1065, 1066, 1067, 1068, 1069, 1070, 1071, 1072, 1073, 1074, 1075, 1076, 1077, 1078, 1079, 1080, 1081, 1082, 1083, 1084, 1085, 1086, 1087, 1088, 1089, 1090, 1091, 1092, 1093, 1094, 1095, 1096, 1097, 1098, 1099, 1100, 1101, 1102, 1103, 1104, 1105, 1106, 1107, 1108, 1109, 1110, 1111, 1112, 1113, 1114, 1115, 1116, 1117, 1118, 1119, 1120, 1121, 1122, 1123, 1124, 1125, 1126, 1127, 1128, 1129, 1130, 1131, 1132, 1133, 1134, 1135, 1136, 1137, 1138, 1139, 1140, 1141, 1142, 1143, 1144, 1145, 1146, 1147, 1148, 1149, 1150, 1151, 1152, 1153, 1154, 1155, 1156, 1157, 1158, 1159, 1160, 1161, 1162, 1163, 1164, 1165, 1166, 1167, 1168, 1169, 1170, 1171, 1172, 1173, 1174, 1175, 1176, 1177, 1178, 1179, 1180, 1181, 1182, 1183, 1184, 1185, 1186, 1187, 1188, 1189, 1190, 1191, 1192, 1193, 1194, 1195, 1196, 1197, 1198, 1199, 1200, 1201, 1202, 1203, 1204, 1205, 1206, 1207, 1208, 1209, 1210, 1211, 1212, 1213, 1214, 1215, 1216, 1217, 1218, 1219, 1220, 1221, 1222, 1223, 1224, 1225, 1226, 1227, 1228, 1229, 1230, 1231, 1232, 1233, 1234, 1235, 1236, 1237, 1238, 1239, 1240, 1241, 1242, 1243, 1244, 1245, 1246, 1247, 1248, 1249, 1250, 1251, 1252, 1253, 1254, 1255, 1256, 1257, 1258, 1259, 1260, 1261, 1262, 1263, 1264, 1265, 1266, 1267, 1268, 1269, 1270, 1271, 1272, 1273, 1274, 1275, 1276, 1277, 1278, 1279, 1280, 1281, 1282, 1283, 1284, 1285, 1286, 1287, 1288, 1289, 1290, 1291, 1292, 1293, 1294, 1295, 1296, 1297, 1298, 1299, 1300, 1301, 1302, 1303, 1304, 1305, 1306, 1307, 1308, 1309, 1310, 1311, 1312, 1313, 1314, 1315, 1316, 1317, 1318, 1319, 1320, 1321, 1322, 1323, 1324, 1325, 1326, 1327, 1328, 1329, 1330, 1331, 1332, 1333, 1334, 1335, 1336, 1337, 1338, 1339, 1340, 1341, 1342, 1343, 1344, 1345, 1346, 1347, 1348, 1349, 1350, 1351, 1352, 1353, 1354, 1355, 1356, 1357, 1358, 1359, 1360, 1361, 1362, 1363, 1364, 1365, 1366, 1367, 1368, 1369, 1370, 1371, 1372, 1373, 1374, 1375, 1376, 1377, 1378, 1379, 1380, 1381, 1382, 1383, 1384, 1385, 1386, 1387, 1388, 1389, 1390, 1391, 1392, 1393, 1394, 1395, 1396, 1397, 1398, 1399, 1400, 1401, 1402, 1403, 1404, 1405, 1406, 1407, 1408, 1409, 1410, 1411, 1412, 1413, 1414, 1415, 1416, 1417, 1418, 1419, 1420, 1421, 1422, 1423, 1424, 1425, 1426, 1427, 1428, 1429, 1430, 1431, 1432, 1433, 1434, 1435, 1436, 1437, 1438, 1439, 1440, 1441, 1442, 1443, 1444, 1445, 1446, 1447, 1448, 1449, 1450, 1451, 1452, 1453, 1454, 1455, 1456, 1457, 1458, 1459, 1460, 1461, 1462, 1463, 1464, 1465, 1466, 1467, 1468, 1469, 1470, 1471, 1472, 1473, 1474, 1475, 1476, 1477, 1478, 1479, 1480, 1481, 1482, 1483, 1484, 1485, 1486, 1487, 1488, 1489, 1490, 1491, 1492, 1493, 1494, 1495, 1496, 1497, 1498, 1499, 1500, 1501, 1502, 1503, 1504, 1505, 1506, 1507, 1508, 1509, 1510, 1511, 1512, 1513, 1514, 1515, 1516, 1517, 1518, 1519, 1520, 1521, 1522, 1523, 1524, 1525, 1526, 1527, 1528, 1529, 1530, 1531, 1532, 1533, 1534, 1535, 1536, 1537, 1538, 1539, 1540, 1541, 1542, 1543, 1544, 1545, 1546, 1547, 1548, 1549, 1550, 1551, 1552, 1553, 1554, 1555, 1556, 1557, 1558, 1559, 1560, 1561, 1562, 1563, 1564, 1565, 1566, 1567, 1568, 1569, 1570, 1571, 1572, 1573, 1574, 1575, 1576, 1577, 1578, 1579, 1580, 1581, 1582, 1583, 1584, 1585, 1586, 1587, 1588, 1589, 1590, 1591, 1592, 1593, 1594, 1595, 1596, 1597, 1598, 1599, 1600, 1601, 1602, 1603, 1604, 1605, 1606, 1607, 1608, 1609, 1610, 1611, 1612, 1613, 1614, 1615, 1616, 1617, 1618, 1619, 1620, 1621, 1622, 1623, 1624, 1625, 1626, 1627, 1628, 1629, 1630, 1631, 1632, 1633, 1634, 1635, 1636, 1637, 1638, 1639, 1640, 1641, 1642, 1643, 1644, 1645, 1646, 1647, 1648, 1649, 1650, 1651, 1652, 1653, 1654, 1655, 1656, 1657, 1658, 1659, 1660, 1661, 1662, 1663, 1664, 1665, 1666, 1667, 1668, 1669, 1670, 1671, 1672, 1673, 1674, 1675, 1676, 1677, 1678, 1679, 1680, 1681, 1682, 1683, 1684, 1685, 1686, 1687, 1688, 1689, 1690, 1691, 1692, 1693, 1694, 1695, 1696, 1697, 1698, 1699, 1700, 1701, 1702, 1703, 1704, 1705, 1706, 1707, 1708, 1709, 1710, 1711, 1712, 1713, 1714, 1715, 1716, 1717, 1718, 1719, 1720, 1721, 1722, 1723, 1724, 1725, 1726, 1727, 1728, 1729, 1730, 1731, 1732, 1733, 1734, 1735, 1736, 1737, 1738, 1739, 1740, 1741, 1742, 1743, 1744, 1745, 1746, 1747, 1748, 1749, 1750, 1751, 1752, 1753, 1754, 1755, 1756, 1757, 1758, 1759, 1760, 1761, 1762, 1763, 1764, 1765, 1766, 1767, 1768, 1769, 1770, 1771, 1772, 1773, 1774, 1775, 1776, 1777, 1778, 1779, 1780, 1781, 1782, 1783, 1784, 1785, 1786, 1787, 1788, 1789, 1790, 1791, 1792, 1793, 1794, 1795, 1796, 1797, 1798, 1799, 1800, 1801, 1802, 1803, 1804, 1805, 1806, 1807, 1808, 1809, 1810, 1811, 1812, 1813, 1814, 1815, 1816, 1817, 1818, 1819, 1820, 1821, 1822, 1823, 1824, 1825, 1826, 1827, 1828, 1829, 1830, 1831, 1832, 1833, 1834, 1835, 1836, 1837, 1838, 1839, 1840, 1841, 1842, 1843, 1844, 1845, 1846, 1847, 1848, 1849, 1850, 1851, 1852, 1853, 1854, 1855, 1856, 1857, 1858, 1859, 1860, 1861, 1862, 1863, 1864, 1865, 1866, 1867, 1868, 1869, 1870, 1871, 1872, 1873, 1874, 1875, 1876, 1877, 1878, 1879, 1880, 1881, 1882, 1883, 1884, 1885, 1886, 1887, 1888, 1889, 1890, 1891, 1892, 1893, 1894, 1895, 1896, 1897, 1898, 1899, 1900, 1901, 1902, 1903, 1904, 1905, 1906, 1907, 1908, 1909, 1910, 1911, 1912, 1913, 1914, 1915, 1916, 1917, 1918, 1919, 1920, 1921, 1922, 1923, 1924, 1925, 1926, 1927, 1928, 1929, 1930, 1931, 1932, 1933, 1934, 1935, 1936, 1937, 1938, 1939, 1940, 1941, 1942, 1943, 1944, 1945, 1946, 1947, 1948, 1949, 1950, 1951, 1952, 1953, 1954, 1955, 1956, 1957, 1958, 1959, 1960, 1961, 1962, 1963, 1964, 1965, 1966, 1967, 1968, 1969, 1970, 1971, 1972, 1973, 1974, 1975, 1976, 1977, 1978, 1979, 1980, 1981, 1982, 1983, 1984, 1985, 1986, 1987, 1988, 1989, 1990, 1991, 1992, 1993, 1994, 1995, 1996, 1997, 1998, 1999, 2000, 2001, 2002, 2003, 2004, 2005, 2006, 2007, 2008, 2

Pursuant to provisions of Executive Order No. 9908, of December 5, 1947 (12 F.R. 822).

All uranium, thorium, and all other materials determined pursuant to Section 5(b)(1) of the Atomic Energy Act of 1946 (60 Stat. 761) to be peculiarly essential to the production of fissionable material, contained in whatever concentration, deposited in the lands covered by this instrument are hereby reserved for the use of the United States, together with the right of the United States through its authorized agents or representatives at any time to enter upon the land and prospect for, mine, and remove the same making just compensation for any damage or injury occasioned thereby. However, such land may be used and any rights otherwise acquired by this disposition may be exercised as if no reservation of such materials had been made, except that when such was required in the extraction of any such material from the land in question, such material may not be transferred or delivered without a license under the Atomic Energy Act of 1946, as it now exists or may hereafter be amended, such material shall be the property of the United States Atomic Energy Commission, and the Commission may require delivery of such material to it by any person or other such material had been separated as such from the ore in which it was contained. If the Commission requires the delivery of such material to it, it shall pay to the person mining or extracting the same, or to such other person as the Commission determines to be entitled therefor, such sums including profits, as the Commission deems fair and reasonable for the discovery, mining, development, production, extraction, and other services performed with respect to such material prior to such delivery, but such payment shall not include any amount on account of the value of such material before removal from the place of deposit in nature. If the Commission does not require delivery of such material to it, the reservation hereby made shall be of no further force or effect.

Together with all and singular the rights, members, hereditaments, and appurtenances to the said premises belonging or in anywise incident or appertaining, except the materials and rights excepted and reserved above.

Said lands were only declared surplus and was assigned to the Federal Farm Mortgage Corporation as disposal agency pursuant to the provisions contained in the above-mentioned Act, Regulations and Order.

TO HAVE AND TO ENJOY, with all and singular the premises before mentioned, except the materials and rights excepted and reserved above, unto the said BOVEN (hereinafter) GRAYNE, its successors and assigns, forever, provided, however, that this conveyance is made and accepted upon such of the conditions hereinafter set forth, which shall be binding upon and enforceable against said GRAYNE, its successors and assigns and each of them.

In the event there is a breach of any of the conditions and covenants herein contained by the GRAYNE, its successors and assigns, whether caused by the legal inability of said GRAYNE, its successors and assigns, to perform said conditions and covenants, or otherwise, during said twenty-year (25-year) period, all right, title and interest in, and to, all of the said premises shall revert to and become the property of the United States of America and its heirs, and it shall have the immediate right of entry upon said premises and the GRAYNE, its successors and assigns, shall forfeit all right, title and interest in said premises and in any and all of the tenements, hereditaments and appurtenances thereto belonging.

PROVIDING, HOWEVER, that the failure on the part of the War Assets Administrator, or his successor in function, to require in any one or more instances, complete performance of any of the conditions or covenants herein contained shall not be construed as a waiver or relinquishment of such future performance, but the obligation of the GRAYNE, its successors and assigns, with respect to such future performance shall continue in full force and effect.

PROVIDED FURTHER, that in the event the War Assets Administrator, or his

successor in function, fails to exercise the option to re-enter the premises for any such term within twenty (20) years from the date hereof, all of said conditions and covenants, together with all rights of the United States of America to re-enter thereon as hereinafter provided, shall as of that date terminate and be extinguished.

The GRANTEE does by the acceptance of this deed covenant and agree, her self and her successors and assigns, forever, as follows:

1. For a period of twenty (20) years from the date of this conveyance, the premises above described shall be continuously used and maintained as and for public park and public recreational purposes, for public use, for public purposes, but for no other purposes.

2. For a period of twenty (20) years from the date of this conveyance, the GRANTEE, its successors and assigns, shall file biennial reports with the War Assets Administrator, or his successor in function, setting forth the use of the property during the preceding two-year (2-year) period, and other pertinent data establishing the continuous use of the property for the purposes set forth above.

3. The GRANTEE will not sell, lease, or otherwise dispose of, any of the premises above described, within twenty (20) years from the date of this conveyance, without first obtaining the written authorization of the Administrator, or his successor in function, by such sale, lease, or other disposal.

4. The GRANTEE may, during the said twenty-year (20-year) period, secure abrogation of all the said conditions and covenants, together with all rights of re-entry hereto contained, except the right of re-entry to the premises as combined in paragraph 5, hereinafter set forth, by: (a) payment of the unamortized portion of the fifty percent (50%) public benefit allowance granted the GRANTEE from the fair value of \$79,000.00, which amortization shall be at the rate of five percent (5%) per year, completed two (2) months of operation in accordance with the terms of transfer; and (b) approval of the War Assets Administrator, or his successor in function.

5. The GRANTEE shall have the right during the existence of any National Emergency declared by the President of the United States of America, or the Congress thereof, to the full and unrestricted possession, control and use of the premises, or any part thereof, without charge; PROVIDED THAT the GRANTEE shall be responsible during the period of such use, if occurring within a period of twenty (20) years from the date of this conveyance, for the entire cost of maintaining the premises, or any portion thereof, so used, and shall pay a fair rental for the use of any installations or structures which have been added thereto without Federal aid; PROVIDED, HOWEVER, that if such use is required after the expiration of a period of twenty (20) years from the date of this conveyance, or the GRANTEE, its successors and assigns, have secured the abrogation of the conditions subsequent to re-entry with all rights of re-entry as hereinabove provided, the GRANTEE shall pay a fair rental for the entire portion of the premises so used.

6. The GRANTEE will erect and maintain an adequate fence around the area hereinbefore described (as restricted to surface only), will post the area in a manner calculated to provide protection of the condition thereof, and will take such other steps as may be necessary to exclude the public from entry into such area, so long as the same remain contaminated.

7. In the event of a breach of any condition or covenant herein imposed, the Administrator or his successor and functions may immediately enter and possess himself of title to the herein conveyed premises for and on behalf of the United States of America.

8. In the event of a breach of any condition or covenant herein imposed, the GRANTEE will, upon demand by the Administrator or his successor and functions, take such actions, including the prosecution of suits or execution of such instruments, as may be necessary or required to evidence transfer of title to the herein conveyed premises to the United States of America.

By the acceptance of this instrument the GRANTEE admits and confesses to full knowledge with respect to the facts contained in the foregoing recital as to the possible contaminated condition of the property.

By acceptance of this instrument and in as further consideration of this conveyance, the GRANTEE for the benefit of only the War Assets Administration and of the GRANTEE, herein covenants and agrees for itself, its successors and assigns, to assume all risk for all personal injuries and property damages arising out of, on, or near, maintenance, use and occupation of the foregoing property and further covenants and agrees to indemnify and save harmless the War Assets Administration and the United States of America, their servants, agents, officers and employees, against any and all liability, claims, causes of action or suits due to or arising out of, or resulting from, immediately or remotely, the possible contaminated condition, ownership, use, occupation or presence of the GRANTEE or any other person upon the property, lawfully or otherwise. This covenant shall not be construed as consent for the State (or the Commission) to the said.

IN WITNESS WHEREOF, the United States of America has caused these presents to be executed in its name by the Federal Farm Mortgage Corporation, and the seal of the said Corporation to be hereunto affixed this 26th day of May 1942.

UNITED STATES OF AMERICA  
By Federal Farm Mortgage Corporation

*J. R. Downey, Jr.*  
J. R. Downey, Jr., Vice President

ATTEST: *W. C. McElbony*  
W. C. McElbony, Assistant Secretary

(Corporate Seal)

*W. C. McElbony*  
*W. C. McElbony*

STATE OF SOUTH CAROLINA  
COUNTY OF RICHLAND

PROBATE

PERSONALLY appeared before me  
that I am a Notary Public for the State of South Carolina, and I have known  
W. O. Medberry, Assistant Secretary, respectively, of Federal Farm  
Mortgage Corporation, of said seal and, and they are and each of them United States  
citizens and are said Corporation, acting for, and behalf of, and in the name  
of the United States of America, deliver to me the foregoing deed for the use and  
purpose therein mentioned, and that I am a Notary Public for the State of South Carolina,  
and I have witnessed the execution thereof.

*Grace S. Chase*  
Vice President

Sworn to and subscribed  
before me this 26th day  
of May, 1919.

*John H. ...*  
Notary Public for South Carolina

(Conformed Copy)

ORDNANCE AND EXPLOSIVE WASTE  
ARCHIVES SEARCH REPORT  
FOR  
FORMER CAMP CROFT ARMY TRAINING FACILITY  
SPARTANBURG, SOUTH CAROLINA  
PROJECT NUMBER I04SC001603

APPENDIX H  
NEWSPAPERS/JOURNALS

APPENDIX H

NEWSPAPERS/JOURNALS

Table of Contents

---

H-1 CAMP CROFT 50th ANNIVERSARY CELEBRATION, P.O. Box 15123, Spartanburg, South Carolina 29302, NEWS RELEASE, Camp Croft 50th Anniversary Celebration St. Luke United Methodist Church Festival Committee, July 26, 1991

H-2 GERMAN POW RETURNS 'HOME', The Spartanburg Herald-Journal, Laura Corbin, Staff Writer, August 9, 1981

H-3 CAMP CROFT WAS ACTIVATED IN '41, The Spartanburg Herald-Journal Bicentennial Edition, July 3, 1976

H-4 CROFT PLAYED KEY ROLE IN INFANTRY TRAINING, The Spartanburg Herald-Journal, undated

H-5 ARMY CAMP TO BE BUILT NEAR HERE, SITE ANNOUNCED FOR REPLACEMENT CENTER FOR ARMY, The Spartanburg Herald, November 9, 1940

H-6 Untitled article, The Paper, September 11, 1991

H-7 CAMP CROFT CHANGED SOLDIERS' LIVES, The Paper, September 11, 1991



**CAMP CROFT 50th ANNIVERSARY CELEBRATION**

P. O. Box 15123

Spartanburg South Carolina 29302

SPARTANBURG COUNTY LIBRARY  
SPARTANBURG, S. C. 29302

Sptbg.  
Pam.  
File

2-26-91

**NEWS RELEASE**

In 1941 major conflict spread throughout the world. Even before the Japanese bombed Pearl Harbor, our Government was making preparations for the war. Evidence of the war effort was taking place in Spartanburg, South Carolina, where a United States Army Infantry Replacement Center was being constructed under quartermaster Major Neil R. McKay. The camp was activated on February 10, 1941 by commanding officer Colonel L. A. Kunzig, who later became a General, and named in honor of Major General Edward Croft, a South Carolinian. The camp played a key role in World War II, providing basic training for thousands of infantry troops. During this time, Spartanburg became the host city to approximately 75,000 men and women of our armed forces annually.

Many of these young men and women elected to return and settle in our community. Others returned to their homes with memories connected to our town and state. On September 13 and 14, 1991, Camp Croft will be the site of a 50th Anniversary Celebration. All veterans of the camp, persons employed at the camp, and the general public are invited to participate in this gala event.

On Friday September 13, a golf tournament will be held at Cotton Creek Golf Club, located on the site of one of the former parade grounds. On Saturday, September 14, the celebration will continue on the grounds of South Carolina School for the Deaf and Blind with open-air entertainment, crafts, children's rides, souvenirs, and display of historical memorabilia of the Camp. A military ceremony dedicated to the veterans and their families, and tours of the camp site will highlight the day's activities.

The festivities will climax with a Saturday night dance in the gymnasium of the school with a live band (music appealing to all ages) but featuring the music of the '40's era.

For additional information, you may write to the address above or you may call Ray Anderson (803) 583-2105 or Helen Salerno (803) 583-9626.

This event is being sponsored by members of St. Luke United Methodist Church which is located on the corner of McKay Avenue and Croft Circle. It is one of the original chapels built in Camp Croft with a heritage that is dear to each member.

Camp Croft 50th Anniversary Celebration  
St. Luke United Methodist Church Festival Committee

SPARTANBURG COUNTY LIBRARY  
 P O BOX 2009  
 SPARTANBURG SC 29308  
 (USPS # 509-569)  
 1 101 1220 00/00/00  
 SPARTANBURG COUNTY

# ing Herald-Journal

burg, S.C. 29301 — Sunday, August 9, 1981 SPARTANBURG COUNTY LIBRARY

PRICE 50 CENTS

## German POW Returns 'Home'

Gerhard Ritters' eyes gleam at the sight of familiar surroundings. His face turns red with excitement as he points out what he recalls; what used to be here or there. He's intrigued by the changes that have taken place.

He stands on a sidewalk which runs along the front of an ordinary green house. To him, it's not just an ordinary sidewalk. He remembers walking down that walkway 35 years ago, when he was but a young man of 20. The concrete and rock surface ran in front of the hospital complex at Camp Croft near Spartanburg.

Ritters is recalling his two years at Camp Croft near Spartanburg during World War II, not as an American soldier stationed there but as a German prisoner of war, interned there.

For the first time since being released in

Staff Writer

**LAURA  
CORBIN**



1946. Ritters this past week visited the Camp Croft area in hopes of seeing familiar sights, of jogging his memory of pleasant, not fearsome, times, and of rekindling long-lost friendships.

"If I were to be asked which time in my life was the most carefree, the nicest," Ritters, who speaks very little English, says through interpreter Spartanburg busi-

nessman Howard Gombert, "I would say my two years at Camp Croft. There, it was a little more relaxed. There were no pressures. It was the best time in my life.

"We never felt under pressure. We felt for the first time in our lives as free people. With the German (political) system we were always under pressure. As prisoners, we were treated as normal human beings, not as prisoners."

Ritters planned his trip to the United States earlier this year, contacting the Spartanburg Area Chamber of Commerce for information about the area and about Camp Croft. Noting that Ritters and Gombert, owner of Gombert Volkswagen/Mazda, are from the same hometown, Krefeld, West Germany, the

Chamber asked Gombert to correspond with Ritters.

Although the two men are about the same age and grew up only about three blocks from each other, they never knew each other until this visit, on which Ritters was accompanied by his sons Martin, 22, and Stefan, 19.

Ritters talks of his days as a prisoner of war, sitting in a restaurant, The Brother's, located where Camp Croft administrative offices used to stand. Looking directly across the street, he recognizes some of the old camp buildings still standing and still being used.

"That's where the motor pool was located." He points toward the back of the Harley Corporation's buildings. Upon investigation, Ritters finds several of the old warehouses, lined in a row. He recalls the neatly-kept shelves on which the Army stacked shoes, socks, clothing and other necessary gear when the Camp served as a supply depot. Some of the structures are refurbished and being used for businesses.

On the Harley property stands the Camp's ice house, apparently abandoned. He later finds a building that was part of the motor pool, being used to house Camp Croft Fire Extinguishing Co.

Ritters is familiar with the motor pool's location because he was made a chauffeur at the Camp, driving workers to the fields to pick peaches and to chop trees, and officers to town for meetings and dinner.

Picking peaches was the reason Ritters and about 250 other German prisoners were transferred from Camp Forest in Tullahoma, Tenn., to Camp Croft. They were to stay for three months. The problem

they were transferred in March, long before the peaches are ready for harvest. "The Germans did pick peaches later," Ritters



**GERHARD RITTERS**  
As A Young Soldier

Ritters recalls other driving assignments, taking an hour's drive each way for prisoners to cut trees. He can't remember exactly where the forest was located, but he recalls driving off in the direction of Pauline and Glenn Springs.

He recalls being assigned to go to a building on the camp and to blow the horn, not being told exactly what he was supposed to do. He did as ordered, and five civilian women who worked at the camp came out of the building and got into the Buick automobile with him.

Ritters didn't wear POW garb because of the fear it might have caused among townspeople for him to be out of the camp. Instead, he wore U.S. Army fatigues. The



the  
g  
d  
n  
is  
se  
I  
it  
ad  
re  
or  
ry  
ae  
it  
be  
ld  
ve  
re

# Ritters Remembers Camp Cr

(Continued From Page 1)

lish to know where to take them, but that was all.

When they attempted to engage Ritters in a conversation, all he could say was that he was a German prisoner of war. "They all got silent. The two in the front with me moved closer to each other and the door. Not another word was spoken, to me or to each other, on the trip to town and on the way back." Later, Ritters happily reports, the women apparently were told they shouldn't fear the Germans, and they began requesting that he take them where they needed to go.

Ritters met and made friends with a lot of civilians who worked at and near the military camp, for the laundry, motor pool and other facilities. He wanted to find two men in particular, a Mr. Fleming who drove one of the motor pool cars, and Frank Ross. Both lived at Glendale, he said. On his brief visit to the Spartanburg area, Ritters was unable to find a trace of either man.

German prisoners were afforded a lot of freedom at Camp Croft, says Ritters, who owns a West German engineering firm that designs and makes specialty manufacturing equipment. Although the Americans had erected towers to overlook the camp, they quickly abandoned them, trusting the German prisoners so much. The gate was always open, Ritters says. "We could walk out, but nobody cared to, we were so well treated here." He had to walk outside the camp to get to the motor pool to pick up his car each morning. He went unattended.

Ritters did other work at the camp, cutting grass and trimming trees, and working in the kitchen. The Germans were given total run of the kitchen. They told the Americans what they wanted, and the Americans gave it to them. The prisoners were paid 10 cents per hour for their work, with which they could purchase items from Camp Croft canteen.

"We could not get the flour used for German rye bread, but we did our best," Ritters says. "The Americans were so pleased that they were sad when the war was over because we gave them such excellent food. We baked birthday cakes and produced many delicacies."

At the end of the war, as a matter of fact, Ritters says, the German prisoners were allowed to continue cooking and eating the good food, even though the Pentagon had ordered that because of the atrocities found in the European concentration camps, the German prisoners would receive only bread and lettuce. "Our (American) commanding officer read the order, but then told us that he knew we were not responsible for the atrocities. He respected us that much; that he would not enforce the Pentagon-order."

Gen. Bradley's troops captured the 1,500 Germans after the German officers surrendered by crossing a nearby mountain ridge into the American camp using a British soldier's truck. "The night before, this British soldier hauling food apparently made a wrong turn and drove directly into our camp," Ritters recalls. "When he said he thought he had made a mistake, we told him it didn't matter; we had no ammunition to capture him and we were going to give ourselves up to the Americans. We ate all the food, and the driver took the officers over the hill to the American camp. In effect, he was a prisoner for several hours," the robust German laughs.

Although there were 1,500 Germans, Ritters says, they had only four tanks, including the captured British tank he was driving. The Americans had more than 100 tanks.

As the sun was setting partially below the horizon, the Germans surrendered. "Daylight was fading as we faced the American troops. It was very humiliating to have to face the Americans."

Ritters says he and his fellow soldiers were not afraid when they were captured, only saddened. "We were very sad because we felt at that point we had the upper hand. We couldn't get supplies. There was no bullet in the tank (which led the 1,500 toward the Americans). We had three cannons whose mechanisms had long been thrown out into the desert. They were totally useless. We were faking it, though. We drove along like we were facing the Americans, ready for battle, but we could not fire a shot."

At 5 a.m., when the sun reappeared, the Germans capitulated. A cease-fire was declared.



POWS ARE PICTURED AT WORK IN THE CAMP CROFT

## HOME LAUNDRY

The German prisoners had everything they wanted at Camp Croft, Ritters says, "even more than the American soldiers." He explains that the prisoners set up a "secret organization," capturing (not stealing, he emphasizes) all types of material ranging from candy bars to clothing. The prisoners sold the items to civilians, who could buy them cheaper there than in town. They also received requests from American officers, who were not allowed in the warehouses, to "capture" certain items.

A complicated network was set up to deliver the items, Ritters says with another laugh. One prisoner would get the item from the warehouse and put it in a designated garbage can. Another would pick up the can, take it to another part of the camp, where the merchandise was delivered. "We never got caught."

To entertain themselves, the German prisoners started their own little zoo, Ritters recalls, complete with cats, dogs, chickens, rabbits and birds. They also played "football," which is soccer, on a field which remains empty except from undergrowth and trees. The Germans enjoyed the camp's canteen, where they could listen to the popular World War II song, composed in Germany, *Lili Marlene*, and to the *Beer Barrel Polka*.

They received regular mail service, writing their families constantly, he says, showing an official prisoner of war post card bearing on one side a picture of him at the Camp and on the other his name and serial number. The mail was directed through Switzerland, which was neutral during the war. One of the post cards was used later in 1964 to prove to the German government that Ritters had been a prisoner of war in the United States. The proof was to help him get compensation for his internment, but no German soldier has every received any, he says.

The German soldiers were required to greet any American officer whose path they crossed, but they were allowed to use the normal German greeting: the raised arm and hand and a "Hell, Hitler." That greeting was allowed throughout the war, Ritters says, until the end, when they were required to stop and instead use a simple salute.

The prisoners had been allowed to wear the German eagle and the Swastika until the end of the war, when they were ordered to remove the patches from their clothing.

Ritters' journey from being a German soldier to being a prisoner of war lasted only about two years. He joined the German army in 1941 at the age of 17 and trained with the cavalry, which actually rode horses into battle. He was sent to Russia and was on his way to Moscow when he was involved in his first battle encounter. He never saw the city.

In December 1941, the troops were turned back toward Germany, where Ritters trained as a tank driver. Six months later he was shipped to Tripoli, Africa, to be with Field Marshal Erwin Rommel's army. The troops moved southward, only to be told that the Americans had invaded in the north. Rommel turned the men around toward Tunisia to face the Americans, Gen. George Patton's and Gen. Omar Bradley's troops.

"For a while, we were very victorious in pushing the Americans back," Ritters says, "not because of equipment, but because we already had experience in desert warfare."

Rommel and some of his soldiers were stopped in Egypt in 1942, while some of the German troops continued fighting the Americans until March of 1943. The American army established itself very strongly and began to counterattack. On May 10, 1943, we ran out of everything: gasoline, ammunition. We stopped and gave ourselves up."

EXTRA SPECIAL EXTRA SPECIAL EXTRA SPECIAL EXTRA SPECIAL



**EXTRA HEAVY DUTY**  
**\$309\***

*Performance Tested*  
**COMMERCIAL MODEL AUTOMATIC DRYER**

- 3 TEMPS • DELICATE FLUFF
- PERMA PRESS COOL DOWN
- Two cycle selection
- Separate start switch
- Commercial cycle
- Porcelain enamel drum
- Heavy-duty heating coils
- Electronically tested dependability

**Giant Capacity**  
**FILTER FL**  
**Washer**  
**WITH BLEACH DISP**

- 4 Water Levels
- Cycles (Regular and Polyester Knit/Form Press)
- Bleach dispenser
- Filter Flo!
- 3 Wash/Rinse temperature select
- energy saving water rinse.

**\$219**



**COMMERCIAL MODEL**  
**3 TEMPS**

EXTRA SPECIAL EXTRA SPECIAL EXTRA SPECIAL EXTRA SPECIAL

MICROWAVES

Spacemaker\*

\$459\*

EXTRA WIDE OVEN CAPACITY  
SPEED EXHAUST FAN  
FREE ANTI-DROP TOP LIGHT  
SPACEMAKER COOKS BY  
TIME AND TEMPERATURE

MICROWAVE CONVENIENCE  
AND MORE KITCHEN COUNTER SPACE!

**THE INCREDIBLE! THE**  
**SPACEMAKER**  
**MICROWAVE OVEN**

Cabinet Mounted with Built-in Vent & Co.



EXPERT  
INSTALLATION  
AVAILABLE



1.3 Cu. Ft.  
This is not a  
strip-down model

\$219

\*DELIVERY OPTIONAL

- Full P
- Oven
- Rack
- Cook

# Camp Croft Was Activated In '41

Soon after the declaration of the emergency by President Franklin Roosevelt on Sept. 16, 1940, the War Department established Camp Croft as one of four camps designed essentially for the basic training of infantry troops.

The other camps were Camp Wheeler in Georgia, Camp Walters in Texas and Camp Roberts in California.

Camp Croft was built on a reservation purchased by the federal government. The cantonment area was about 2,500 acres of the 22,000 acre reservation.

On Feb. 10, 1941, Camp Croft was activated as the U.S. Army's Infantry Replacement Training Center by Colonel L.A. Kunzig, the commanding officer.

The camp, named for Major General Edward Croft, a South Carolinian born in 1875, contained graves of revolutionary soldiers and train from 18,000 to 20,000 soldiers every three months.

The \$10,000,000 complex had water lines, a sewerage system, a system of surfaced roads within the cantonment area, a hospital, a laundry, cold storage, highways leading to it and railway terminals. The constructing headmaster

The Chamber of Commerce suggested that the general range and maneuver area be used again for farming purposes. They also suggested that the cantonment area be used for housing and that commercial and industrial businesses be encouraged to use the warehouse and service area.

In 1946 the barracks at Camp Croft began to be renovated for use as apartments for veterans. Four hundred veterans had applied for this housing.

By April, 1947, 286 families had built and settled in the cantonment area and 21 families had settled in the area outside the cantonment where they were using the camp's water system. A small housing development outside the camp also used the water and sewerage systems. Twenty-three industries were located within the cantonment and 13 were adjacent the camp.

The Little Theatre, located in one of the camp buildings, is rented from the County Foundation at a rate of \$1 per year. The foundation owns about 200 acres of property that could be used for development in the camp area.



Teaching Civilians How To Soldier



## Monroe Doctrine Told Europe Not To Meddle

American interest in its freedom and in pursuing its ideas of freedom in spheres of its influence was born early in the history of this nation.

The Monroe Doctrine set forth the U.S. attitude about foreign influence in the western hemisphere. It was announced by President James Monroe in a message to Congress, December 2, 1823.

The key portion of the message containing the statement of doctrine follows:

"In the discussions to which this interest has given rise, and in the arrangements by which they may terminate, the occasion has been deemed proper for asserting as a principle in which rights and interests of the United States are involved, that the American continents, by the free and independent condition which they have assumed and maintain, are henceforth not to be considered as subjects for future colonization by any European power... we should consider any attempt on their part to extend their system to any portion of this hemisphere as dangerous to our peace and safety..."

The deepest point of the Atlantic Ocean is the Puerto

from 1940... Gen. L. K. ...  
Gen. Alexander M. ...  
Gen. G. H. Hubener, Gen. ...  
Francis V. Logan, Maj. Gen. ...  
John H. Hester, Col. Wilbur ...  
Fox, Gen. Paul Ransom, Gen. ...  
Charles J. ...  
D. S. Wilson and Col. ...  
Griffith.

The men at Camp Croft enjoyed the hospitality of the city of Spartanburg, which had six USO clubs. The men also had their own clubs at the camp including a Service Club, Officer's Club and the regimental headquarters. Many Spartans visited the camp to partake of the entertainment offered there.

Camp Croft was used in 1945 as a separation point for discharged soldiers. On Sept. 19, 1945, First Sergeant Joseph P. Hindock of Warren, Penn., was the first man discharged through Camp Croft.

In the first five weeks of the separation point operation 1,550 officers and enlisted men left the service from Camp Croft. Each day averaged about 75 enlisted men and nine officers. The first group to leave the camp contained eight enlisted men.

On Jan. 25, 1945, at the request of the Spartanburg County Legislative Delegation, city council, Chamber of Commerce, Veteran Housing Commission, civic clubs and other organizations in the county, the trustees of the Spartanburg County Foundation met with the War Assets Administration concerning the purchase of Camp Croft. It had been decided that the camp would not be made into a permanent military base.

The trustees of the County Foundation bought the camp in March, 1945, for more than \$1 million. David W. Anderson was placed in charge of Camp Croft surplus.

The foundation was given authority to dispose of the surplus and property in any way they saw fit, and the profits they obtained were to be used for the benefit of the county.

... .. Camp Croft ... ..

# Croft Played Key Role In Infantry Training

Camp Croft played a key role in World War II providing basic training for thousands of Infantry troops.

## Auditorium Built In 1951

Plans were mapped in 1946 for the construction of an auditorium near the main business district of Spartanburg.

Construction of the \$1,250,000 Memorial Auditorium began in 1950 and was completed late in 1951. On Dec. 20, 1951 the new Spartanburg Memorial Auditorium was filled to capacity for its grand opening.

The new auditorium was a joint city and county project and it brought fresh entertainment and excitement to Spartanburg. Big bands, symphonies, national and world-famous artists and Broadway hits played Spartanburg.

In 1957, the Memorial Auditorium Commission reported its first deficit and it has financial problems since then.

The main auditorium seats 3,400 which the arena has a seating capacity of 2,500 and is able to handle 1,000 persons at a banquet.

On Feb. 10, 1941, Camp Croft was activated as the U.S. Army's Infantry Replacement Training Center by Col. L.A. Kunzig, the commanding officer. The camp was built on 22,000 acres of land purchased by the federal government and was located outside the city limits.

The camp was named for Maj. Gen. Edward Croft, a South Carolinian born in 1875. The camp trained 18,000 to 20,000 soldiers every three months.

The \$10 million complex had water lines, a sewerage system, a system of surfaced roads within the cantonment area, a hospital, a laundry, cold storage, highways leading to it and railway terminals.

Commanders of Camp Croft from 1940 were Gen. L.A. Kunzig; Gen. O.W. Griswold, Gen. Alexander M. Patch, Jr., Gen. G.R. Hubener, Gen. Francis V. Logan, Gen. John H. Hester, Col. Witbur J. Fox, Gen. Paul Ransom, Gen. Charles P. Thompson Jr., Gen. D.S. Wilson and Col. F.D. Griffith.

Camp Croft was used in 1945 as a separation point for discharged soldiers. On Sept. 19, 1945, First Sgt. Joseph P. Hudock, of Warren, Pa., was the first man discharged through Camp Croft.

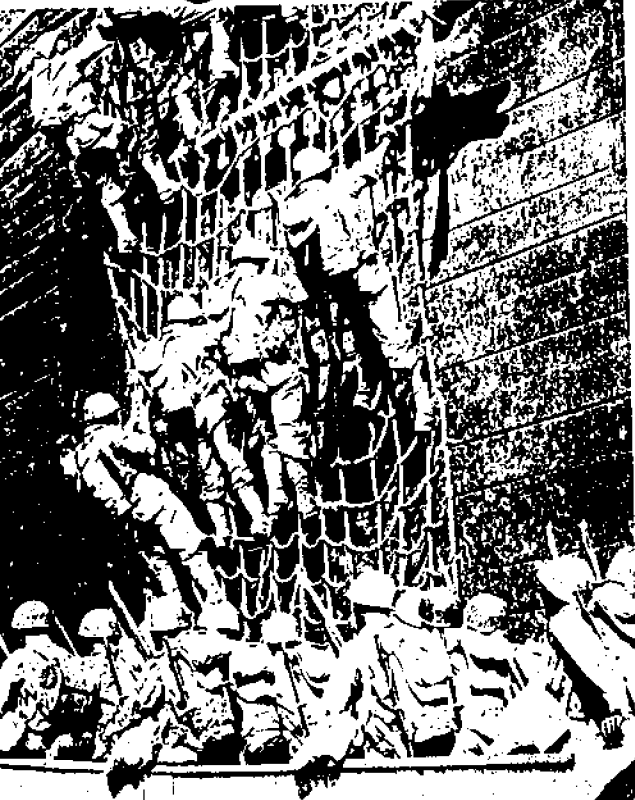

Training Was Tough, Constant



H-5

# ARMY CAMP TO BE BUILT NEAR HERE

Italians Thrown Back By Blows  
 Greeks Deliver

Where Are  
 Established

BRITAIN TO GET GREENVILLE HIGH SITE ANNOUNCED  
 HALF OF PLANES IN THRILLER, 12-4 FOR REPLACEMENT  
 PRODUCED IN U. S.

Three Against Two More  
 Reported Destroyed  
 NEW MEXICO THEY BEGAN  
 Strong Resistance Offered  
 by the Greeks  
 in the Mountains  
 in the Mountains

ENGLAND CLAIMS  
 VESSELS REPLACED  
 AS FAST AS SUNK  
 British Says 1,000,000 Tons  
 Replaced by New, Rebuilt  
 in 11 Months

U. S. CROP REPORT  
 SHOWS INCREASE  
 IN COTTON YIELD  
 Estimated Last Year's  
 Yield at 12,047,770 Bales  
 2,000,000 More in 1941

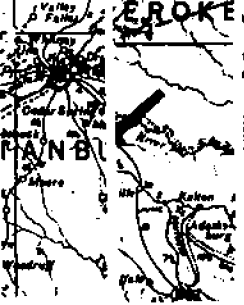

# EXTRA The Spburg Herald EXTRA

# WAR EXPLOD N PACIFIC AS JAPS ATT TWO U. S. BASES

Here's the Pacific War Zone

UNITED STATES  
 JAPAN

Members Strike at  
 Harbor, Philippine  
 Without Warning

its Raging Over Honolulu And  
 Movement in Progress Off Island  
 Ship is Torpedoed

### NEWS BULLETINS

NEW YORK, Dec. 7 (AP)—Japanese planes today were reported to have bombed the U. S. Army base at Pearl Harbor, Hawaii, and the U. S. Navy base at Ford Island, Hawaii. The planes were reported to have dropped incendiary bombs and to have caused considerable damage to the buildings and equipment at the bases. The Japanese planes were reported to have been shot down by U. S. anti-aircraft fire.

BRITISH CAPTURE Japs Try to Smash Blocked  
 7,500 AXIS ARMY  
 NAVY, AIR STRENGTH COMPARED  
 FORCES IN LIBYA

COLD WINDS BLOW  
 IN SOUTH AS SNOW  
 HITS SOME STATE

Japs Bombed War  
 The U. S. Navy reported today that it had received reports of a Japanese attack on Pearl Harbor, Hawaii, on December 7, 1941. The attack was reported to have been a surprise attack, and the Japanese planes were reported to have caused considerable damage to the base.

U. S. Navy  
 The U. S. Navy reported today that it had received reports of a Japanese attack on Pearl Harbor, Hawaii, on December 7, 1941. The attack was reported to have been a surprise attack, and the Japanese planes were reported to have caused considerable damage to the base.

U. S. Navy  
 The U. S. Navy reported today that it had received reports of a Japanese attack on Pearl Harbor, Hawaii, on December 7, 1941. The attack was reported to have been a surprise attack, and the Japanese planes were reported to have caused considerable damage to the base.

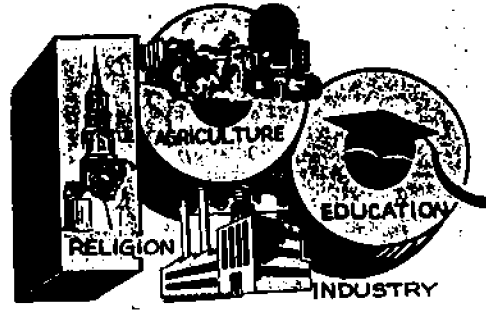

# World War II Dominates 1940-50 Era

By VICKI CASEY  
 Staff Writer

The 1940-50 decade in Spartanburg County was dominated by war activities — just as was the rest of the nation.

The start of the conflict in Europe in 1939 began to demand more and more attention from American interests.

President Roosevelt's domestic program for recovery from the Great Depression was also interrupted.

In Spartanburg, a major activity of the war effort centered around the location of an Army basic training center a few miles east of the city. Spartan James F. Byrnes was tapped by the president to help in a number of chores in helping to gear the nation for war and Byrnes later became a strong influence in the national government's efforts to end the war and achieve peace.

Major conflict began in Europe on Sept. 1, 1939 when Germany struck Poland in a fierce blitzkrieg. Two days later England and France declared war on Germany and soon the entire European continent was at war. The United States soon realized that it would be impossible to continue its policy of isolation. A move began to arm the United States. Aid was granted for England. The United States was on the verge of war. Roosevelt was re-elected and became the first president to serve three terms in office.

The country was steadily drifting into war with Germany when the Japanese attacked Pearl Harbor on Dec. 7, 1941. Congress declared war on Japan the next day and three days later declared war on the Germans and Italians.

The war continued; as the Allies closed in on Germany, Roosevelt died suddenly at Warm Springs, Ga. Harry S. Truman, who was chosen to serve as vice president during Roosevelt's fourth term in office assumed the presidency. On May 7, 1945, German surrendered unconditionally.

Three months later Truman ordered the new

father's car business after the war. But he couldn't stay away and returned after a year. The couple now lives in the peaceful Camp Croft community in a house built where a barrack once stood. In fact, they've had many veterans visit their home from out of town just to recall their basic training days.

Dozens of soldiers, like Salerno, fell in love in Spartanburg. "It was heaven for the women. You could just have your pick," Helen Salerno says with a laugh. The camp brought men and women together who never would have crossed paths otherwise.

"I always say that Uncle Sam shipped me my husband," says Mary Ruth DeLaddy of Pacolet. Her husband, Eugene, was living in Chicago when he was called into the service just a few months before bombing at Pearl Harbor. He spent 19 months overseas before coming to Camp Croft to train other young soldiers how to fight a war.

"Some of them were real young and would get homesick because they hadn't been home in three or four weeks. I could sympathize with them because I had spent two years and nine months before I had a furlough," he says.

DeLaddy met his wife at a dance. They were married and he never returned to Chicago. "I found the Lord, my wife and had my baby, all that I hold dear, in Spartanburg," says DeLaddy, who grew up an orphan. "I didn't have a family and my wife was from Pacolet, and she had a lot of family here. I could have taken the labels out of my cloths in Chicago, died, and no one would have ever known who I was," he said. "But Spartanburg's home, now."

A thread of memories like DeLaddy's stretches across the United States. It was an unforgettable time, because most soldiers had never been away from home before coming to Spartanburg. They left home-cooked meals for kitchen patrol. They left peace for early morning calisthenics and 10- to 15-mile hikes

(Continued on Page 32.)



Military wedding at Camp Croft

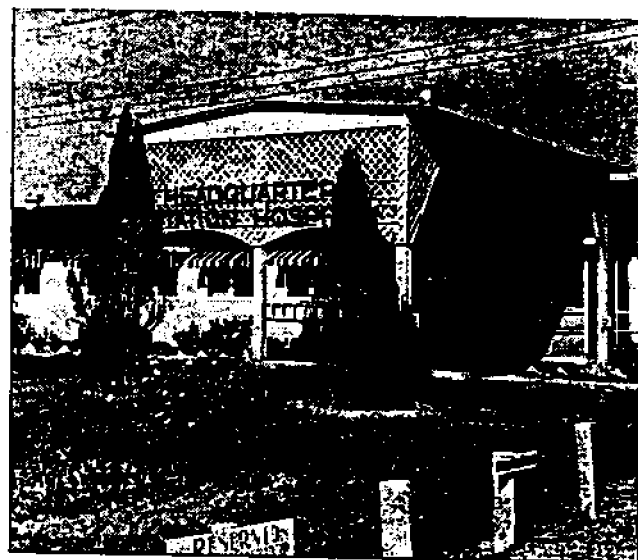

Station Hospital Headquarters

## Camp Croft changed soldiers' lives

Four generations ago the world was being sucked into the vortex of World War II. Life began changing for everyone.

Businesses, schools, factories, farms and homes were emptied of men as the service plucked them out of their prime and put them into the battlefields. Young mothers were often left to take care of the children and stretch their dollars while their husbands were sent away to learn how to take machine guns apart and prepare for a war that seemed foreign to them all; combat that was an ocean away from all they had ever known.

The fighting left no one untouched. It forced rations on meat, sugar,

rubber and gasoline. Families were issued a limited number of stamps to buy canned goods. The motto on a 1943 War Ration Stamp Book read: "If you don't need it, don't buy it." It was a slogan that became a part of living.

Soldiers with families received \$100 a month. Single men got paid \$50. The government was a conservative one and instilled the trait into its country. At one point during the war, it became illegal for a person in the United States to purchase more than three pairs of shoes in a year. Women couldn't buy "nonessential" high-heel shoes because excess materials went into durable soles for combat.

It was the worst of times and the best of times. Across the country, everyone anticipated war, prepared for it. In 1940, Spartanburg became a focal point as it was picked to host a basic training camp for the country's infantry. Long before the bomb was dropped on Pearl Harbor on Dec. 7, 1941, plans were being made here for Camp Croft.

Construction for the camp began in the winter of 1940 after the government had moved in and bought 22,000 acres of farm land about six miles southeast of the city. In 90 days, rows of barracks and army supply houses sprang up like

(Continued on Page 24.)



Pam.  
Ella

**T**o a generation entering retirement years, Camp Croft brings back memories of youth, fear, war and love.

Fifty years ago, thousands and thousands of soldiers were passing through Spartanburg on their way to war. The young men who came to the basic training camp during World War II were expected to learn how to fight and how to survive.

From chemical and jungle warfare to hand grenades and bazookas, in 13 weeks a man was to be ready to carry his own once he left Spartanburg. After crawling on their bellies under barbed wire fences, repeating drill after drill, hiking hundreds of miles through rough terrain carrying heavy packs, a civilian quickly became a rugged soldier.

"We all grew up fast," says Paul Lasnier, a first sergeant and instructor at Camp Croft in 1944. "You had to learn how to think for yourself."

More than 250,000 soldiers received their basic training at Camp Croft from the time it opened in 1941 until the war had ended in 1945. Today, several hundred of those soldiers live in the area. And many more residents can still recall what it was like having a busy military training camp just five miles outside of town.

"It was a different time from now. Everyone just seemed real close. It was like you had to be close because you'd probably never see each other again," said Helen Salerno, who worked as a secretary at the Officer's Club and met her husband, Bill, during the final year of Camp Croft.

Bill Salerno and Lasnier are like many World War II veterans who eventually called Spartanburg home. After the war, Lasnier returned to his job in Connecticut and upon retirement moved back.

Salerno, who came to Camp Croft to be discharged, returned with his wife, Helen, to his home in New York and worked in his

*'Boys became men. What we taught the men at Camp Croft, kept them alive. I served with Gen. Patton and he said the troops from Camp Croft were the finest replacement troops in America. ...'*

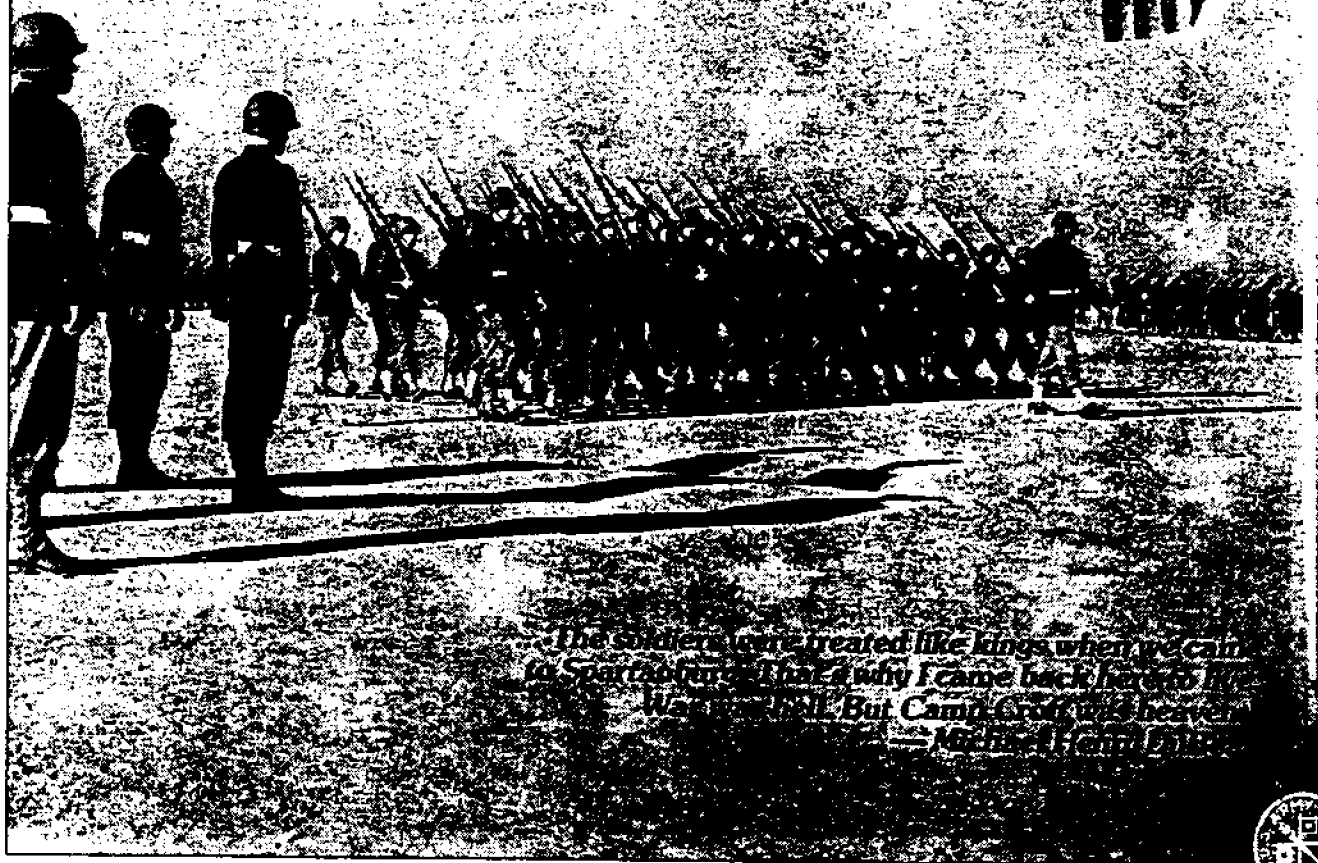

*The soldiers were treated like kings when we came to Spartanburg. That's why I came back here to live. War is hell. But Camp Croft was heaven.*  
— *Michael Hand*

father's car business after the war. But he couldn't stay away and returned after a year. The couple now lives in the peaceful Camp Croft community in a house built where a barrack once stood. In fact, they've had many veterans visit their home from out of town just to recall their basic training days.

Dozens of soldiers, like Salerno, fell in love in Spartanburg. "It was heaven for the women. You could just have your pick," Helen Salerno says with a laugh. The camp brought men and women together who never would have crossed paths otherwise.

"I always say that Uncle Sam shipped me my husband," says Mary Ruth DeLaddy of Pacolet. Her husband, Eugene, was living in Chicago when he was called into the service just a few months before bombing at Pearl Harbor. He spent 19 months overseas before coming to Camp Croft to train other young soldiers how to fight a war.

"Some of them were real young and would get homesick because they hadn't been home in three or four weeks. I could sympathize with them because I had spent two years and nine months before I had a furlough," he says.

DeLaddy met his wife at a dance. They were married and he never returned to Chicago. "I found the Lord, my wife and had my baby, all that I hold dear, in Spartanburg," says DeLaddy, who grew up an orphan. "I didn't have a family and my wife was from Pacolet, and she had a lot of family here. I could have taken the labels out of my cloths in Chicago, died, and no one would have ever known who I was," he said. "But Spartanburg's home, now."

A thread of memories like DeLaddy's stretches across the United States. It was an unforgettable time, because most soldiers had never been away from home before coming to Spartanburg. They left home-cooked meals for kitchen patrol. They left peace for early morning calisthenics and 10- to 15-mile hikes  
(Continued on Page 32.)



Military wedding at Camp Croft



Station Hospital Headquarters

## Camp Croft changed soldiers' lives

Four generations ago the world was being sucked into the vortex of World War II. Life began changing for everyone.

Businesses, schools, factories, farms and homes were emptied of men as the service plucked them out of their prime and put them into the battlefields. Young mothers were often left to take care of the children and stretch their dollars while their husbands were sent away to learn how to take machine guns apart and prepare for a war that seemed foreign to them all; combat that was an ocean away from all they had ever known.

The fighting left no one untouched. It forced rations on meat, sugar,

rubber and gasoline. Families were issued a limited number of stamps to buy canned goods. The motto on a 1943 War Ration Stamp Book read: "If you don't need it, don't buy it." It was a slogan that became a part of living.

Soldiers with families received \$100 a month. Single men got paid \$50. The government was a conservative one and instilled the trait into its country. At one point during the war, it became illegal for a person in the United States to purchase more than three pairs of shoes in a year. Women couldn't buy "nonessential" high-heel shoes because excess materials went into durable soles for combat.

It was the worst of times and the best of times. Across the country, everyone anticipated war, prepared for it. In 1940, Spartanburg became a focal point as it was picked to host a basic training camp for the country's infantry. Long before the bomb was dropped on Pearl Harbor on Dec. 7, 1941, plans were being made here for Camp Croft.

Construction for the camp began in the winter of 1940 after the government had moved in and bought 22,000 acres of farm land about six miles southeast of the city. In 90 days, rows of barracks and army supply houses sprang up like  
(Continued on Page 24.)

ORDNANCE AND EXPLOSIVE WASTE  
ARCHIVES SEARCH REPORT  
FOR  
FORMER CAMP CROFT ARMY TRAINING FACILITY  
SPARTANBURG, SOUTH CAROLINA  
PROJECT NUMBER I04SC001603

APPENDIX I

INTERVIEWS

APPENDIX I

INTERVIEWS

Table of Contents

---

I-1 Conversation Record with Messrs. George and David Mullinax, military retiree and Spartanburg Fire Department employee, respectively and the FUDS, Camp Croft OEW ASR site inspection team, 25 March 1993

I-2 Conversation Record with Mr. Jim Thompson, President, Spartanburg Chamber of Commerce and the FUDS Camp Croft OEW ASR site inspection team, 25 March 1993

I-3 Conversation Record with Mr. Jerry Perry, Superintendent, Croft State Park and the FUDS Camp Croft OEW ASR site inspection team, 24 March 1993

I-4 Conversation Record with Mr. Jeff Diller, Park Ranger, Croft State Park and the FUDS Camp Croft OEW ASR site inspection team, 25 March 1993

I-5 Telephone Conversation Record with Mr. Wayne Bogan, local district representative, USACE, Charleston District and Mr. Mike Harper, USATCES FUDS Team Leader, 28 July 1993

**CONVERSATION RECORD**

Time: 0800

Date: 25 March 1993

TYPE: Visit

LOCATION OF VISIT: Spartanburg Fire Department and Croft State Park (formerly Camp Croft Firing Ranges)

PERSONS CONTACTED: Messrs. George and David Mullinax

ORGANIZATION: Military Retiree and Spartanburg Fire Department

TELEPHONE NUMBER: (803) 582-5831

SUBJECT: Former Camp Croft Infantry Replacement Training Center

SUMMARY:

-----  
On 25 March 1993, Messrs. Jodi Bausman, CENCR and Mike Harper, USATCES met with Messrs. George and David Mullinax at the Spartanburg Fire Department. George is the "resident student" in Spartanburg regarding the former Camp Croft. The discussion included:

a. A grenade recently being located near the sewer line not far from where the sewer line crosses Highview Road just to the southeast of the former Camp Croft cantonment area.

b. Verifying, on mapping, the present day locations of the former Camp Croft grenade court, various ammunition firing ranges, gas chambers, bayonet court, ammunition storage area, parade grounds, and various points of interest in the cantonment area.

c. Location where David, as a child, had located a number of what he called "mustard gas packets".

Later in the day, these gentlemen accompanied the site inspection (SI) team to Croft State Park, where they introduced the team to Mr. Jeff Diller, a Park Ranger. Mr. Diller, see separate conversation record in this ASR, stated that he could walk through the woods in the park and find ammunition at will.

Messrs. Mullinax relayed information to the team regarding eighty grenades being located in the northwestern part of the park, stacked near a tree. We walked into this area, not far to the south of the intersection of Dairy Ridge Road and Croft State Park Road. The SI team located structures and berms for what was formerly a 300 yard moving target. George found an army ground signal. This signal, however, would not have been of the WWII era.

Both of these gentlemen impressed the SI team as being competent and reliable sources of information.

ACTION REQUIRED: Complete SI report with recommendations on the necessary remediation of the former Camp Croft

Mike Harper

**CONVERSATION RECORD**

Time: 0930

Date: 25 March 1993

TYPE: Visit

LOCATION OF VISIT: Spartanburg Chamber of Commerce Offices

PERSON CONTACTED: Mr. Jim Thompson, President, Spartanburg  
Chamber of Commerce

ORGANIZATION: Spartanburg Chamber of Commerce

TELEPHONE NUMBER: (803) 594-5020

SUBJECT: Former Camp Croft Infantry Replacement Training Center

SUMMARY:

-----  
On 25 March 1993, Messrs. Jodi Bausman, CENCR and Mike Harper, USATCES met with Mr. Jim Thompson, President of the Spartanburg Chamber of Commerce at the Chamber's offices. Jim, after finding out that we had just interviewed George Mullinax, didn't feel that he could contribute much more than George.

There was, however, a short discussion and Mr. Thompson gave the SI team a 50th Anniversary Brochure for the former Camp Croft. He had been the principal force in arranging for this anniversary. The brochure contains a wealth of historical photographs of the old camp.

The team thanked Mr. Thompson for his assistance and ended the visit.

ACTION REQUIRED: Complete SI report with recommendations on the necessary remediation of the former Camp Croft.

Mike Harper

**CONVERSATION RECORD**

Time: 1200

Date: 24 March 1993

TYPE: Visit

LOCATION OF VISIT: Croft State Park, Superintendent's Office

PERSON CONTACTED: Mr. Jerry Perry, Superintendent, Croft State  
Park

ORGANIZATION: Croft State Park

TELEPHONE NUMBER: (803) 585-0419

SUBJECT: Former Camp Croft Infantry Replacement Training Center

SUMMARY:

-----  
On 24 March 1993, Messrs. Jodi Bausman, CENCR and Mike Harper, USATCES, Site Inspection (SI) team met with Mr. Jerry Perry, the newly assigned Superintendent of Croft State Park. During discussion, Jerry told the SI team of two mortar rounds being located on the park near a swimming pool in the vicinity of Lake Craig.

Jerry, also, provided the SI team with mapping of Croft State Park and authorization to assess areas of the park not accessible to the public, providing combinations to gate locks.

The team thanked Mr. Perry and ended the visit.

ACTION REQUIRED: Complete SI report with recommendations on the necessary remediation of the former Camp Croft.

Mike Harper

CONVERSATION RECORD:

Time: 1100

Date: 25 March 1993

TYPE: Visit

LOCATION OF VISIT: Croft State Park

PERSON CONTACTED: Mr. Jeff Diller

ORGANIZATION: Croft State Park

TELEPHONE NUMBER: (803) 585-0419

SUBJECT: Former Camp Croft Infantry Replacement Training Center

SUMMARY:

-----  
On 25 March 1993, Messrs. Jodi Bausman, CENCR and Mike Harper, USATCES met with Mr. Jeff Diller, Park Ranger, Croft State Park. During conversation with Jeff, he stated that he could find ordnance in the park's woods "at will". In the past, he claimed to have "found projectiles, mortars, hand grenades, illumination rounds".

Mr. Diller pointed out the area on a park map where he claimed to have located the most ordnance. This area was in the northwest portion of the park, not far to the south of the intersection of Dairy Ridge Road and Croft State Park Road.

Jeff was busy and unable to assist us any further. The team thanked him for his time and ended the visit.

ACTION REQUIRED: Complete SI report with recommendations on the necessary remediation of the former Camp Croft.

Mike Harper



**CONVERSATION RECORD**

Times: Various

Date: 28 July 1993

TYPE: Telephone

PERSON CONTACTED: Mr. Wayne Bogan, Local District Representative  
for FUDS Camp Croft

ORGANIZATION: USACE, Charleston District

TELEPHONE NUMBER: (803) 727-4366

SUBJECT: OEW Recently Located at Croft State Park (former Camp  
Croft)**SUMMARY:**

-----

On 28 July 1993, Mr. Mike Harper, USATCES called Mr. Bogan to discuss a sketch of a portion of former Camp Croft in the Whitestone Area which depicts a large target pit. This document, F-16, corresponds with photographs at J-17 through J-24. Document F-16 dated 19 June 1991 states that a shell was found in that area last winter. There were other documents discussed (F-19, 20 and 21). These documents dated 30 October, 1991, also, regard a live round of ammunition (mortar) which had recently been discovered in the Whitestone Area. Calls were placed to determine who had prepared the sketch (F-16) and whether or not Documents F-19 through 21 were referring to the same round discussed in Document F-16.

Mr. Bogan stated that the sketch (F-16) was drawn by a former employee of the district and that documents F-19 through F-21 were prepared by himself and addressed separate incidents. The documents that he prepared were in reference to a "live" mortar located about 100 yards into Henningston Road, approaching from the east.

I thanked Wayne for the information and finished our conversation.

**ACTION REQUIRED:** Complete SI report with recommendations on the necessary remediation of the former Camp Croft.

Mike Harper

ORDNANCE AND EXPLOSIVE WASTE  
ARCHIVES SEARCH REPORT  
FOR  
FORMER CAMP CROFT ARMY TRAINING FACILITY  
SPARTANBURG, SOUTH CAROLINA  
PROJECT NUMBER I04SC001603

APPENDIX J

PRESENT SITE PHOTOGRAPHS

## APPENDIX J

### PRESENT SITE PHOTOGRAPHS

#### Table of Contents

---

- J-1 Entrance to Croft State Park (previously ammunition training ranges which supported infantry training at the former Camp Croft IRTC)
- J-2, and J-3 Small Arms Ammunition (SAA) bullets, .30 Caliber
- J-4, J-5, and J-6 Trench Mortar Weapon, Fin Assembly (Cartridge Container and Blades)
- J-7 Dairy Ridge Road, 3 miles in length running from the SW to NE, separated the former Camp Croft cantonment area from its ammunition firing ranges
- J-8, and J-9 ECMs, located on northside of Dairy Ridge Road, that were used for ammunition storage in support of the former camp's training ranges.
- J-10, J-11, and, J-12 Training range tower just north of Dairy Ridge Road and just north of former Camp Croft ammunition training ranges
- J-13 View downrange from the former camp training range tower
- J-14 Body and Fuze, Shell, Illuminating, M83 (60mm Trench Mortar Weapon)
- J-15 Trench Mortar Weapon, Fin Assembly (Cartridge Container and Blades)
- J-16 Trench Mortar Weapon, Fin Assembly and Link for 20mm Cartridge
- J-17 Fuze, Percussion, D.A., No. 253 Mk. I and portion of Trench Mortar Weapon, Fin Assembly
- J-18 Fuze, Percussion, D.A., No. 253 Mk. I
- J-19 thru J-26 Target pit for rifle and automatic rifles ranges (200, 300 and 500 yards), pit is approximately one-half mile in width
- J-27, and J-28 Entrance to Lake Edwin W. Johnson area
- J-29 Lake Edwin W. Johnson
- J-30 thru J-34 Clay roadway leading away from Lake Edwin W. Johnson which is littered with SAA bullets, .30 Caliber
- J-35 thru J-38 Remnants of moving target, anti-tank

J-39 Land area running parallel to target depicted at photographs J-35 through J-38

J-40 Signal, Illumination, Ground: Smoke, M60 series

J-41 Sewer line off of Highview Road which runs north from Dairy Ridge Road (Grenade found here)

J-42, and J-43 Kohler, Administrative Offices, located to the east of former Camp Croft cantonment area

J-44 View eastwardly from Kohler parking lot, location of former Camp Croft gas chambers and gas obstacle course

J-45 Water reservoir, former Camp Croft and camp cantonment area stone markers

J-46, and J-47 Former Camp Croft cantonment area stone markers at the J-47 intersection of Ridge Way Avenue and Patch Road

J-48 Grading operation, location of the former Camp Croft grenade court

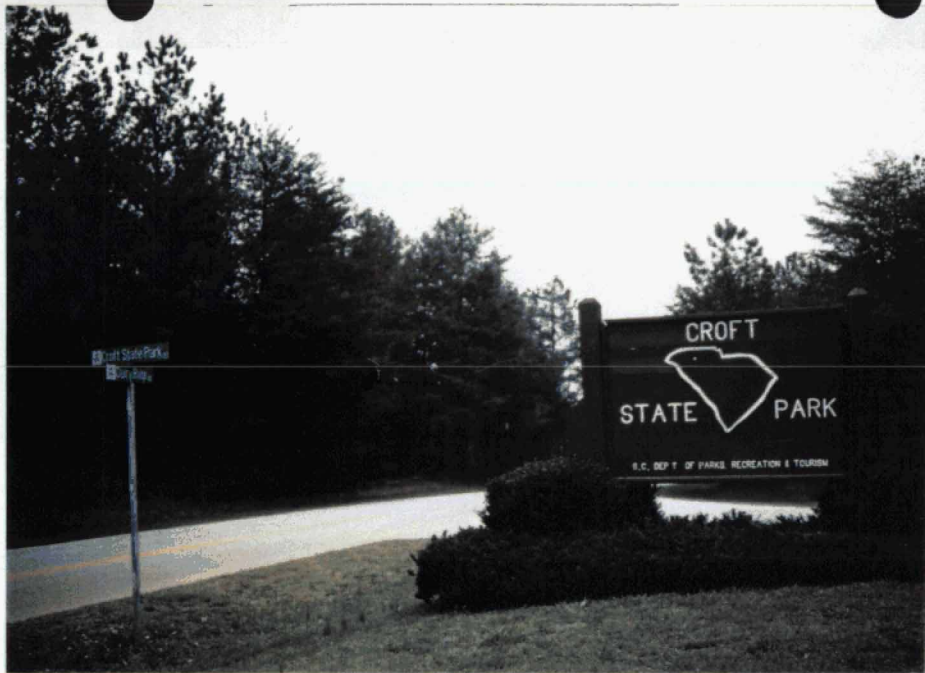

Entrance to Croft State Park

J-1



Small Arms Ammunition (SAA) bullets, .30 Caliber

J-2



Small Arms Ammunition (SAA) bullets, .30 Caliber

J-3



Trench Mortar Weapon, Fin Assembly  
(Cartridge container and blades)

J-4



Trench Mortar Weapon, Fin Assembly  
(Cartridge container and blades)

J-5



Trench Mortar Weapon, Fin Assembly  
(Cartridge container and blades)

J-6



Dairy Ridge Road, separates Cantonment Area  
from Ammunition Firing Ranges

J-7



ECMs, located on north side of Dairy Ridge Road

J-8



ECMs, located on north side of Dairy Ridge Road **J-9**



Training Range Tower just north of Dairy Ridge Rd **J-10**



Training Range Tower just north of Dairy Ridge Rd **J-11**



Training Range Tower just north of Dairy Ridge Rd **J-12**



View downrange from the former  
camp training range tower

**J-13**



Body and Fuze, Shell, Illuminating, M83  
(60 mm Trench Mortar Weapon)

**J-14**



Trench Mortar Weapon, Fin Assembly  
(Cartridge container and blades)

**J-15**



Trench Mortar Weapon, Fin Assembly  
and Link for 20mm Cartridge

**J-16**





Fuze, Percussion, D.A., NO. 253 Mk. I and Portion  
of Trench Mortar Weapon, Fin Assembly

**J-17**

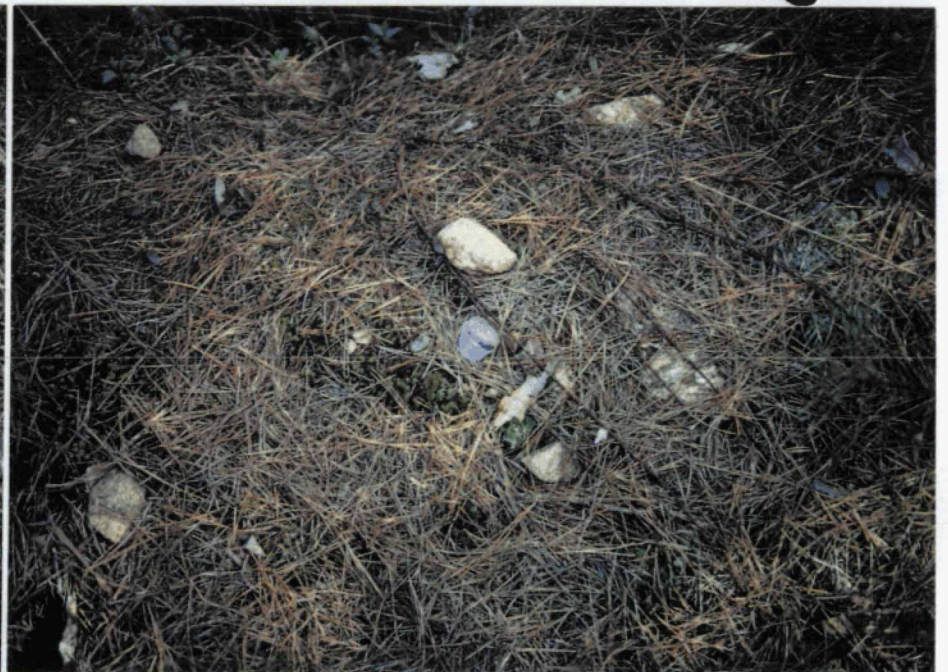

Fuze, Percussion, D.A., No. 253 Mk. I

**J-18**



Target pit for Rifle and Automatic Rifle Ranges  
(200, 300 and 500 yards)

**J-19**



Target pit for Rifle and Automatic Rifle Ranges  
(200, 300 and 500 yards)

**J-20**



Target pit for Rifle and Automatic Rifle Ranges  
(200, 300 and 500 yards)

**J-21**



Target pit for Rifle and Automatic Rifle Ranges  
(200, 300 and 500 yards)

**J-22**



Target pit for Rifle and Automatic Rifle Ranges  
(200, 300 and 500 yards)

**J-23**



Target pit for Rifle and Automatic Rifle Ranges  
(200, 300 and 500 yards)

**J-24**



Target pit for Rifle and Automatic Rifle Ranges  
(200, 300 and 500 yards)

**J-25**



Target pit for Rifle and Automatic Rifle Ranges  
(200, 300 and 500 yards)

**J-26**



Entrance to Lake Edwin W. Johnson Area

**J-27**



Entrance to Lake Edwin W. Johnson Area

**J-28**



Lake Edwin W. Johnson

J-29



Clay Roadway leading away from Lake Edwin W. Johnson, which is littered with SAA Bullets

J-30



Clay Roadway leading away from Lake Edwin W. Johnson, which is littered with SAA Bullets

J-31



Clay Roadway leading away from Lake Edwin W. Johnson, which is littered with SAA Bullets

J-32



Clay Roadway leading away from Lake Edwin  
W. Johnson, which is littered with SAA Bullets

**J-33**



Clay Roadway leading away from Lake Edwin  
W. Johnson, which is littered with SAA Bullets

**J-34**



Remnants of moving target, anti-tank

**J-35**

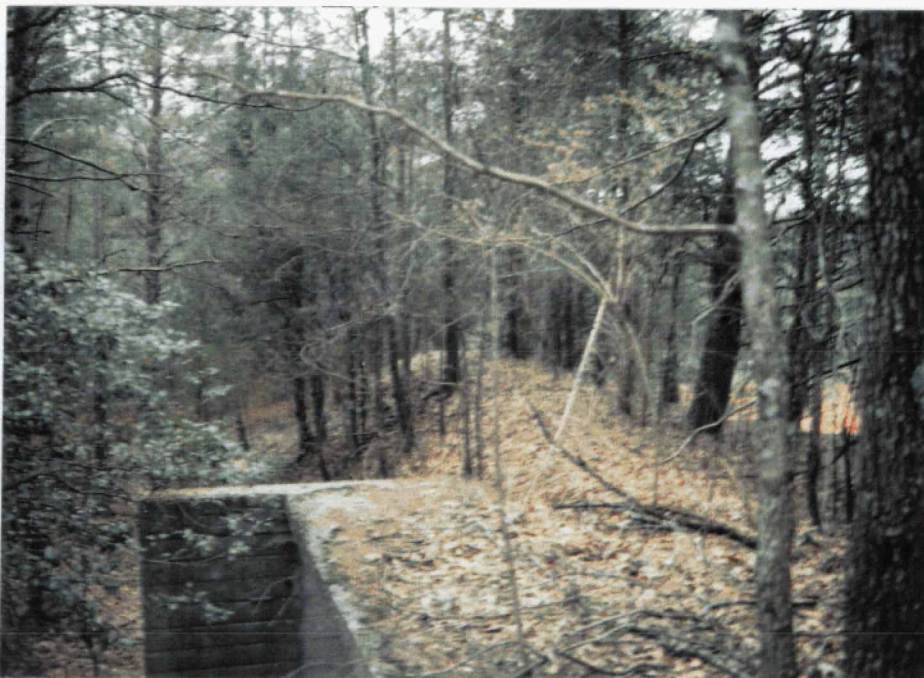

Remnants of moving target, anti-tank

**J-36**



Remnants of moving target, anti-tank

J-37



Remnants of moving target, anti-tank

J-38



Land area running parallel to target depicted at photographs J-35 through J-38

J-39



Signal, Illumination, Ground: Smoke, M60 Series

J-40



Sewer line off of Highview Road which runs north from Dairy Ridge Road (Grenade found here) **J-41**



Kohler, Administrative Offices, located to the East of former Camp Croft cantonment area **J-42**



Kohler, Administrative Offices, located to the East of former Camp Croft cantonment area **J-43**



View eastward from Kohler parking lot, location of former Camp Croft gas chambers and gas obstacle course **J-44**



Water Reservoir, former Camp Croft and cantonment area stone markers

J-45



Former Camp Croft cantonment area stone markers

J-46



Former Camp Croft cantonment area stone markers

J-47



Grading operation, location of former Camp Croft grenade court

J-48



ORDNANCE AND EXPLOSIVE WASTE  
ARCHIVES SEARCH REPORT  
FOR  
FORMER CAMP CROFT ARMY TRAINING FACILITY  
SPARTANBURG, SOUTH CAROLINA  
PROJECT NUMBER I04SC001603

APPENDIX K  
HISTORICAL PHOTOGRAPHS

APPENDIX K

HISTORICAL PHOTOGRAPHS

Table of Contents

-----  
K-1 Special Souvenir Edition of the 50th Anniversary Celebration  
of Camp Croft, S.C., FROM WARTIME HERITAGE TO PEACEFUL  
COMMUNITY, CAMP CROFT, 1941-1991, 50 YEARS, St. Luke United  
Methodist Church and The 50th Anniversary Committee, 1991

K-2 Aerial Photograph, former Camp Croft cantonment area,  
Originator and Date Unknown

# CAMP CROFT

## 50TH ANNIVERSARY CELEBRATION



*This Publication is a  
Special Souvenir Edition  
of the 50th Anniversary  
Celebration of Camp Croft, S.C.*

The Anniversary Committee offers special thanks to the following for their research and contributions in making the publication possible:

Paula Cauthen  
George Mullinax  
Spartanburg County Library  
Spartanburg Herald-Journal  
Wofford College Library  
John Woodring



Camp Croft, Spartanburg, SC was named in  
honor of Major General Edward Croft (1874 - 1938)



CAMP CROFT, S.P.A.

During the spring and summer of 1940, the Japanese navy menaced Southeast Asia and Hitler's armies blitzed their way across France. While Pearl Harbor was still far in the future, it was obvious to most Americans that the cause of freedom was in grave danger. President Roosevelt ordered most of the National Guard into federal service and signed legislation which authorized the first peace-time draft in American history. As General of the Army Omar Bradley later said, "a gigantic mess ensued." All the existing military facilities were swamped by various units trying to mobilize and bring their readiness up to Army standards. Without a major new building program, there would be no place to teach the draftees how to be soldiers and get them ready to join their units.

On November 8, 1940, the War Department announced that one of these new training centers would be located in Spartanburg County. The climate and terrain were perfect for year-round training. The community had supported nearby Camp Wadsworth with enthusiasm during World War I, and had fought unsuccessfully to make it a permanent installation. Long known as the railroad "hub city of the Southeast," Spartanburg also boasted excellent air and bus terminals as well as a pioneering radio station and a strong business community. The city also was the home of James F. Byrnes, one of Washington's most powerful and effective political leaders — a fact not lost on the military establishment.

Over the next few months, the government spent \$450,000 for the use of about 20,000 acres of land in Spartanburg and Union

Counties. The military reservation was named "Camp Croft" in honor of Major General Edward Croft (1874-1938), a South Carolinian who had served with distinction as an officer in World War I and later retired as chief of infantry. Located on the Southern Railroad about five miles southeast of Spartanburg, the cantonment area surrounding post headquarters represented a \$10 million investment in structures, water lines and paved roads. Throughout the winter of 1940-1941, approximately 10,000 construction workers labored on the site, their wages becoming profits for local businesses offering everything from food and shelter to Saturday night entertainment.

The Camp Croft Infantry Replacement Center was officially activated on February 10, 1941, under the command of Colonel L. A. Kunzig. With housing for some 20,000 trainees and support personnel, the post came to be nearly as large as the City of Spartanburg, which then had a population of about 25,000. Camp Croft had 140,000 square feet of warehouse space, nine barber shops, six chapels, a large Post Exchange (PX) and an 800-bed hospital. For recreation, the troops could choose from four movie theaters and an amphitheater, several officers' and service clubs, ten athletic fields, four boxing arenas and three swimming pools. The two post libraries subscribed to almost 300 periodicals and displayed a collection of 9,000 books. Post commanders were a series of general officers: O. W. Griswold, G. R. Hubner, Paul Ransom, Charles P.



## SPARTANBURG, S.C., 1941

Thompson Jr., and D. S. Wilson.

Who were the young men who came to Spartanburg and Camp Croft during World War II? The largest number were Yankees from New York, Pennsylvania and New England. They arrived in groups of 16,000, were introduced to Army discipline, food and friendly drill sergeants, and began the standard, 13-week cycle of basic training. They fired M-1 carbines, Browning Automatic Rifles, anti-tank rocket launchers (bazookas) infantry mortars down Spartanburg County ranges. They ran obstacle and fit-to-fight courses, and even conducted amphibious warfare training on Duncan Park Lake. Once they left Camp Croft, they joined units to fight battles all around the world — North Africa and Italy; Normandy and the Rhine; New Guinea and the Philippines. Some — like Henry Kissinger and Zero Mostel — became famous.

A small group of Camp Croft residents came from even farther away. About 500 prisoners of war from Rommel's Afrika Corps were brought to Spartanburg to help bring in the 1944 peach crop, which was threatened by a desperate farm-labor shortage. The Germans stayed to work in various on-post jobs such as the bakeries, motor pools and laundries, and made many local friends. While worried about their families back home, they found their captivity at Camp Croft almost a relief after the anxieties of citizenship and military service in the Third Reich.

While Spartans rejoiced at the surrender of Japan on August 14, 1945,

they realized that they would soon be saying goodbye to many of their wartime friends. Training cycles at Camp Croft slowed to a gradual stop, and on September 19, 1945, First Sergeant Joseph P. Hudock of Warren, Pennsylvania, became the first of many soldiers to receive his discharge at the post. Some of the veterans liked the area so much that they decided to stay behind after the Army left. As civilians, they have many contributions to the growth and development of post-war Spartanburg over many years.

Having decided not to convert Camp Croft into a permanent military installation, the War Department agreed early in 1945 to sell the cantonment area, the sewer and water plants, and a good portion of the training center to the Spartanburg County Foundation for \$1 million. By 1947, conversion of the post to peace-time use was well underway, and few investments have returned as much to the people of the community. The land where troops once trained to fight for freedom is now used for residential streets, homes and churches; for industrial and commercial businesses providing hundreds of jobs; and for recreation (Croft State Park and the Spartanburg Little Theater).

Americans settled in Spartanburg County several decades before the Revolution, and so the story of Camp Croft as an Army post is but a brief chapter in the long history of this region. But it is an important story that still has many implications for our future.



*Top: Main Street looking east,  
crowd waiting for Christmas  
Parade.*

*Left: Montgomery Building on  
North Church Street.*

*Right: Andrews Building.*





GREYHOUND

UNION BUS DEPOT



Y.M.C.A. BUILDING ON MAIN STREET



MAIN STREET LOOKING WEST





ADMINISTRATION BUILDING  
AT WOFFORD COLLEGE



CARNEGIE LIBRARY  
AT WOFFORD COLLEGE

CAMP CROFT COURTS



NORTH CHURCH STREET

K-1



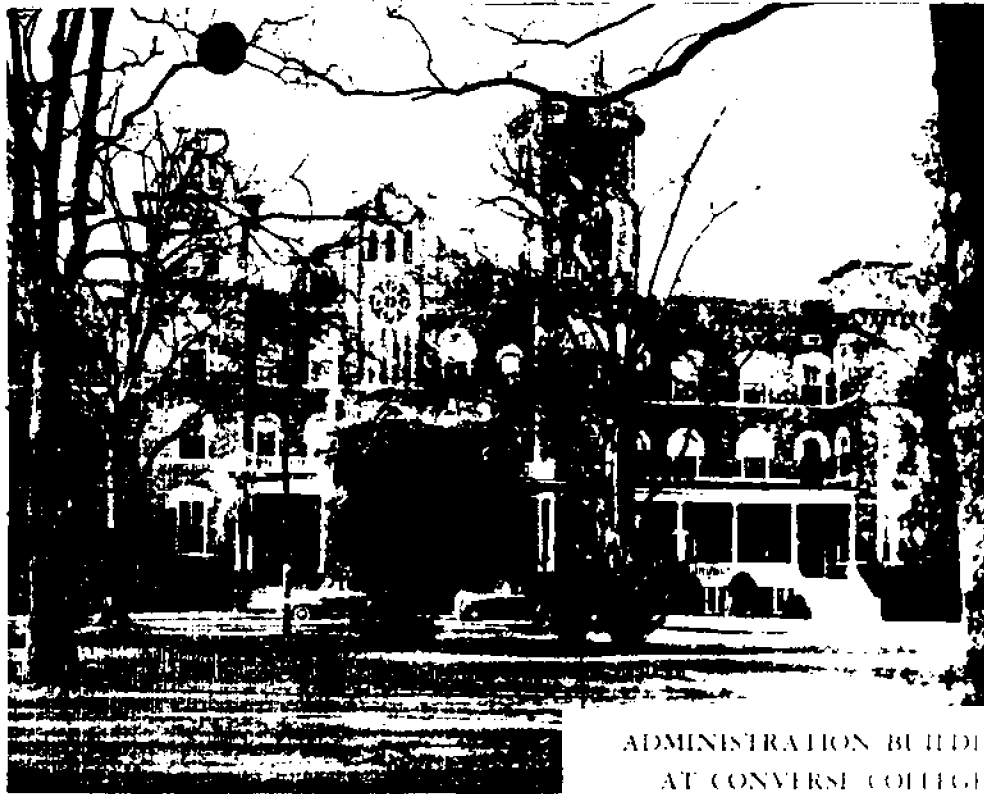

ADMINISTRATION BUILDING  
AT CONVERSE COLLEGE  
LOOKING WEST ON MAIN STREET  
AT DANIEL MORGAN STATUE

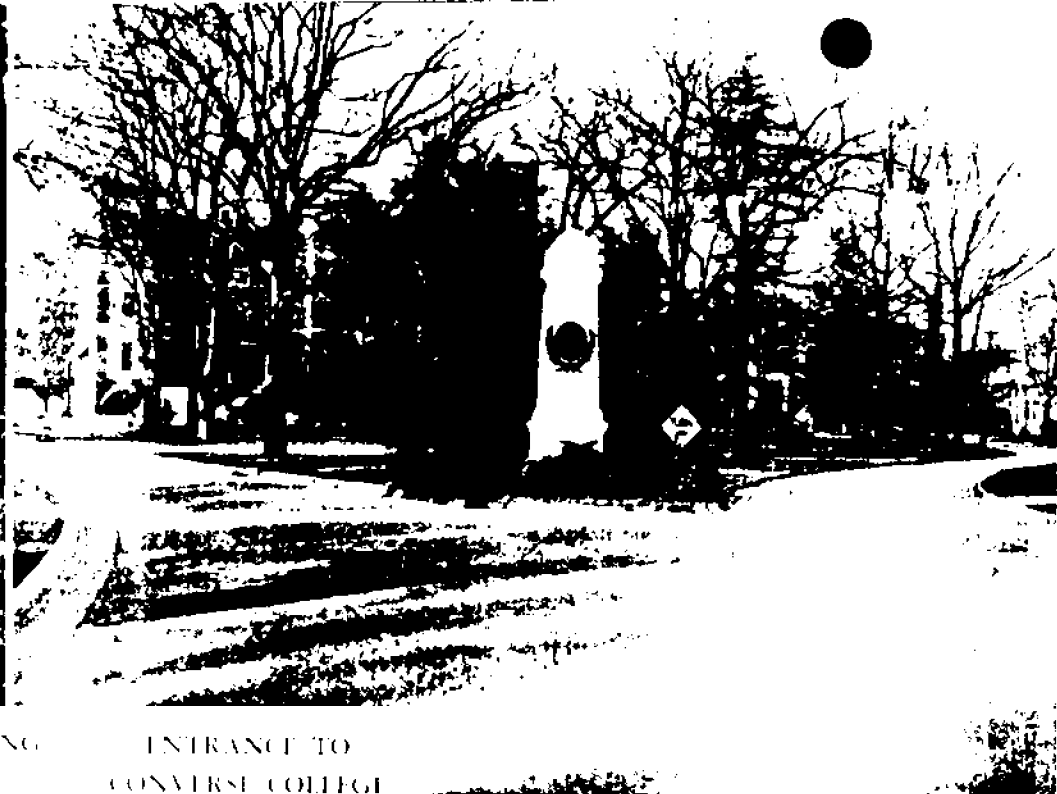

ENTRANCE TO  
CONVERSE COLLEGE  
OTIS BOULEVARD

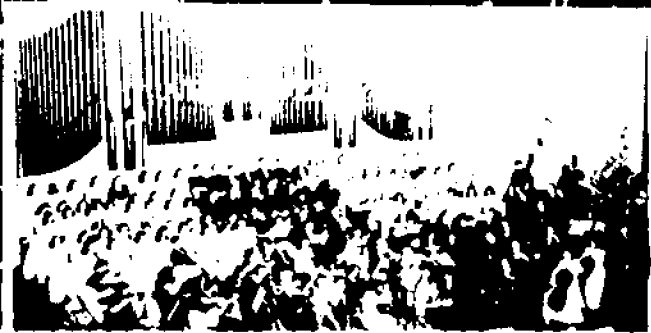
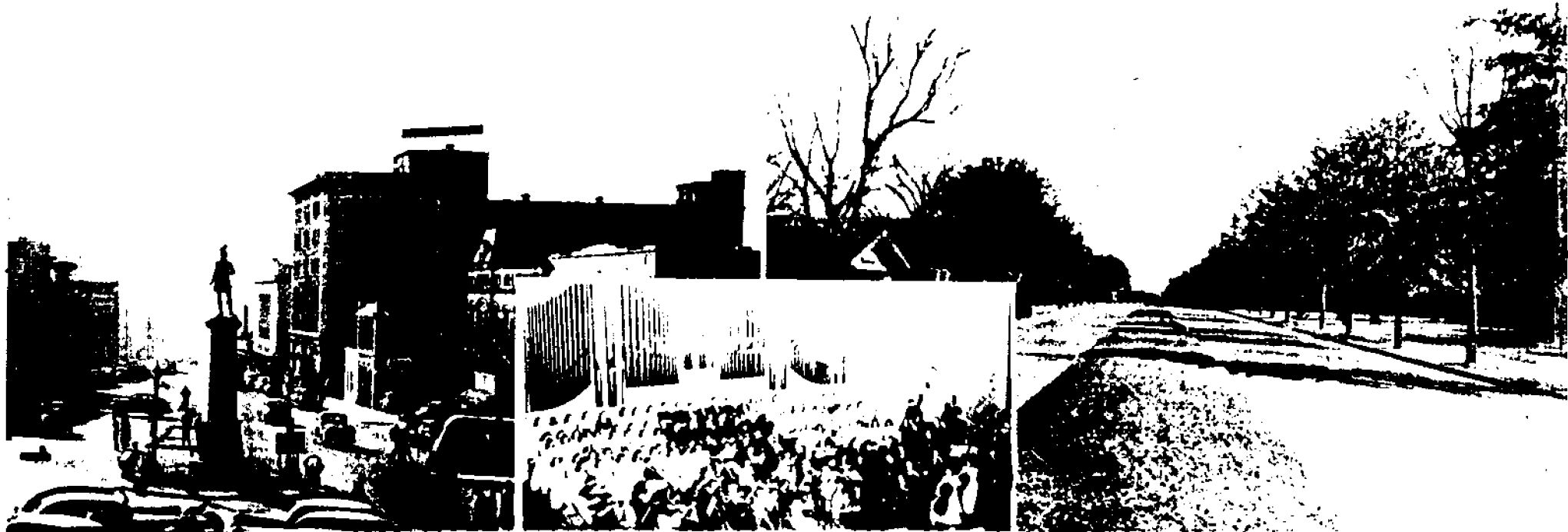

VIEW OF BUILDING AND STATUE

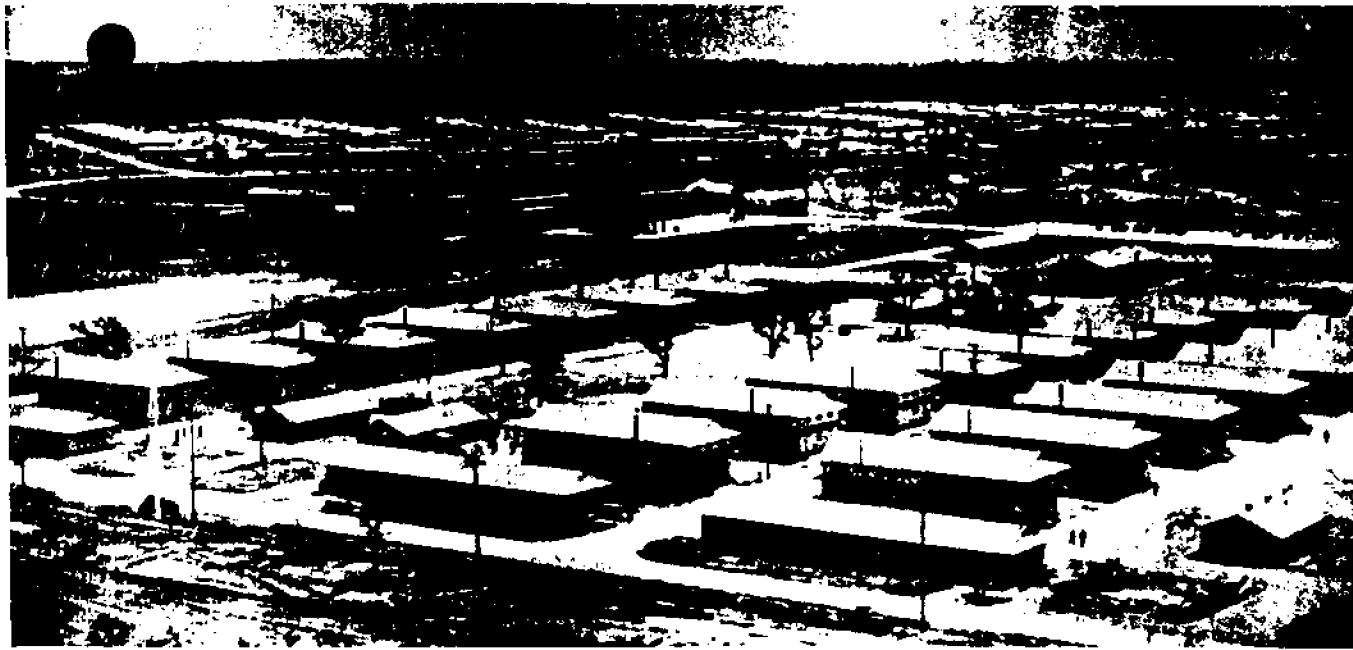

ENLISTED MEN'S BARRACKS



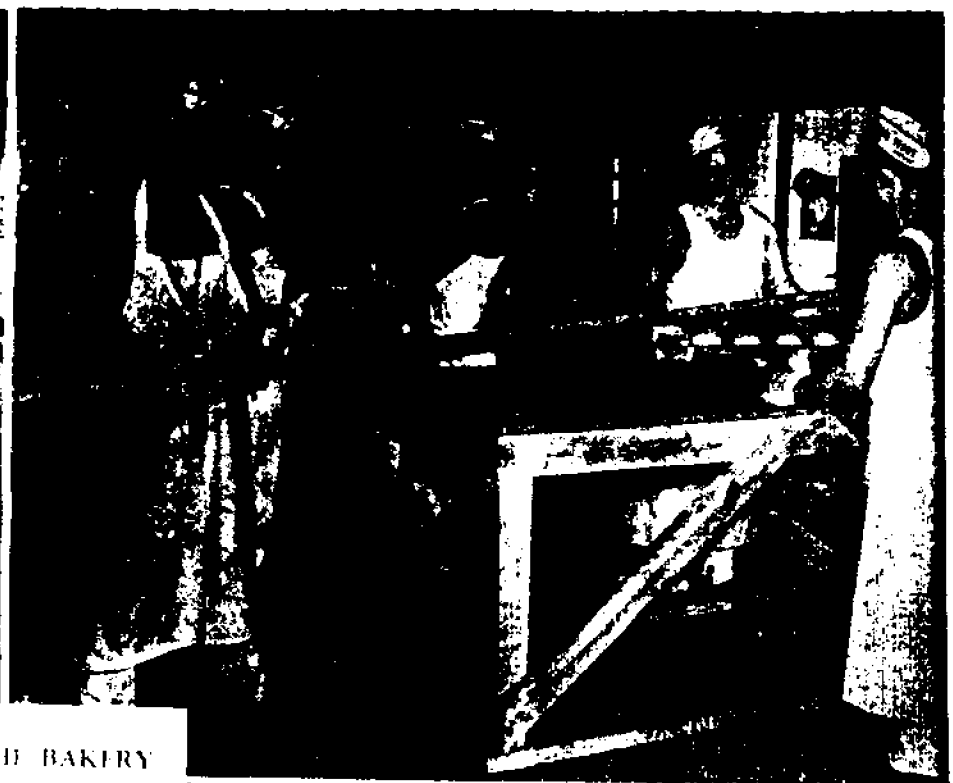
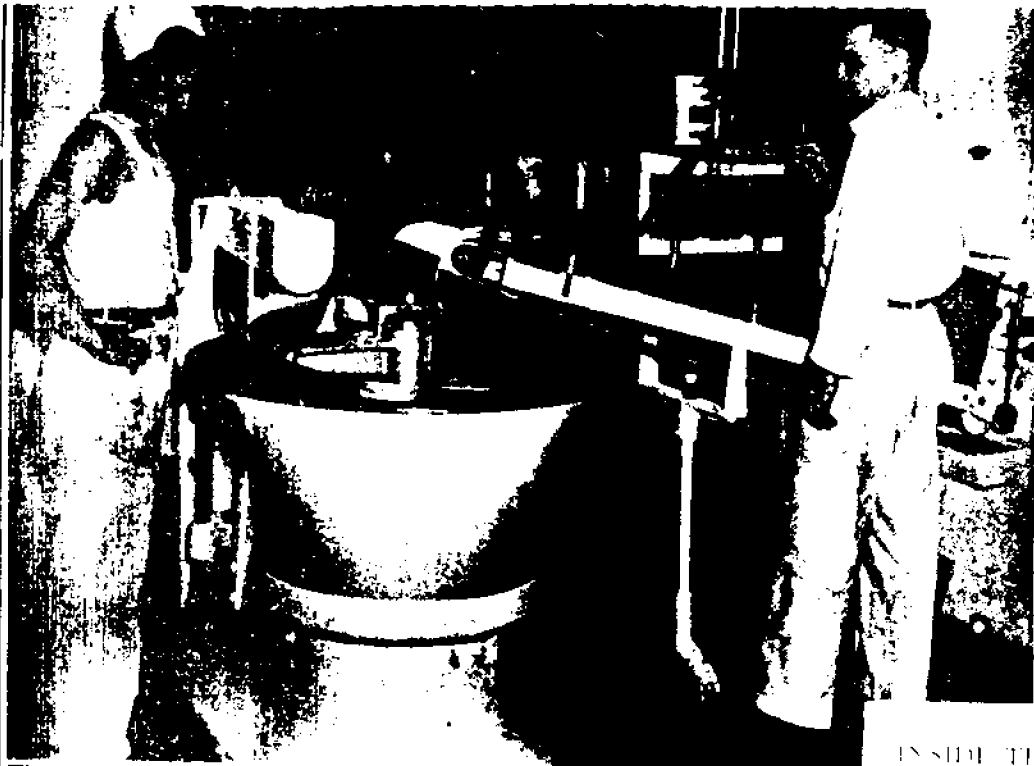

INSIDE THE BAKERY  
AT CAMP CROFT

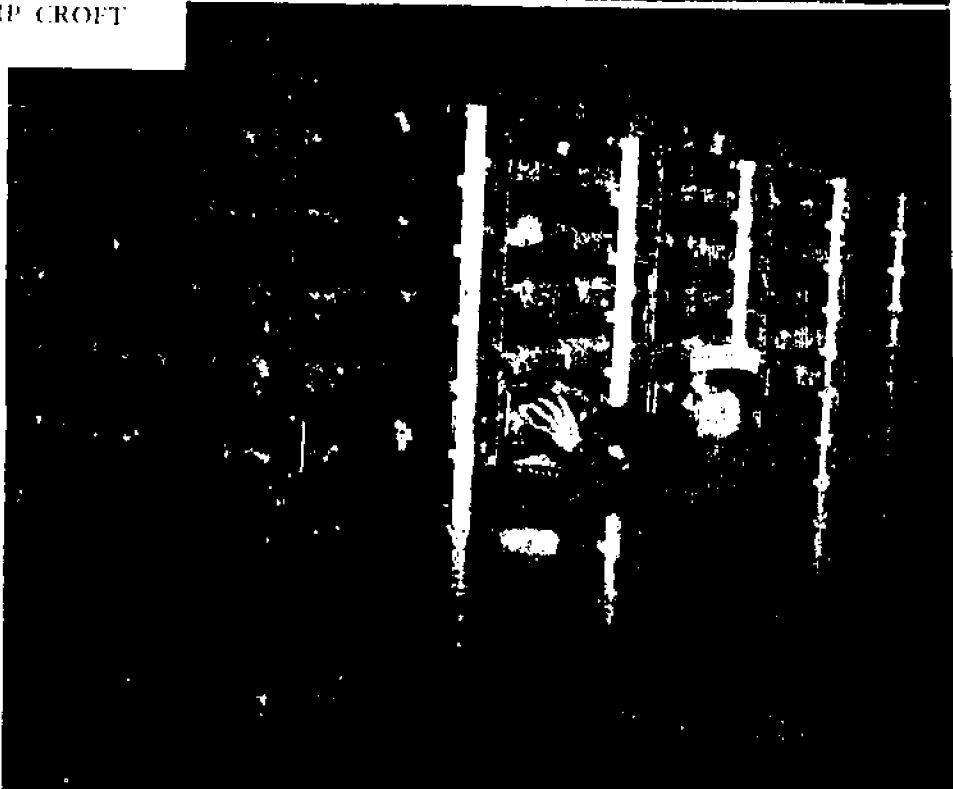

1-2



Selectees learning the working parts of motors at the Motor Repair School at Camp Croft

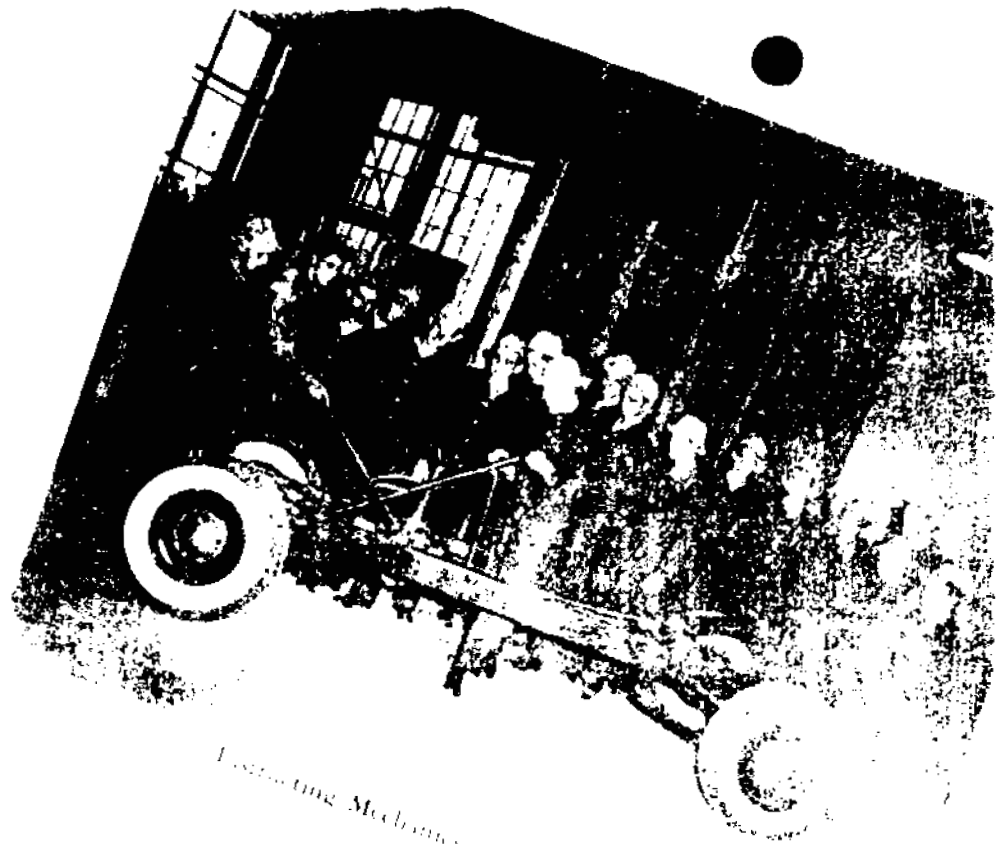

Instructing Mechanics of M

Interior View of the Motor Repair Building



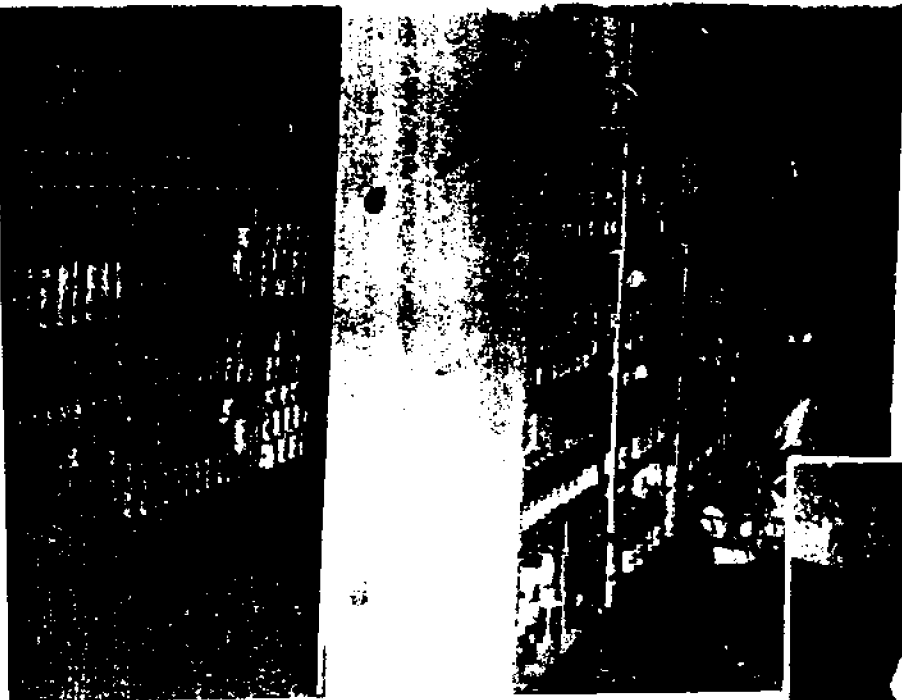

COMISSARY

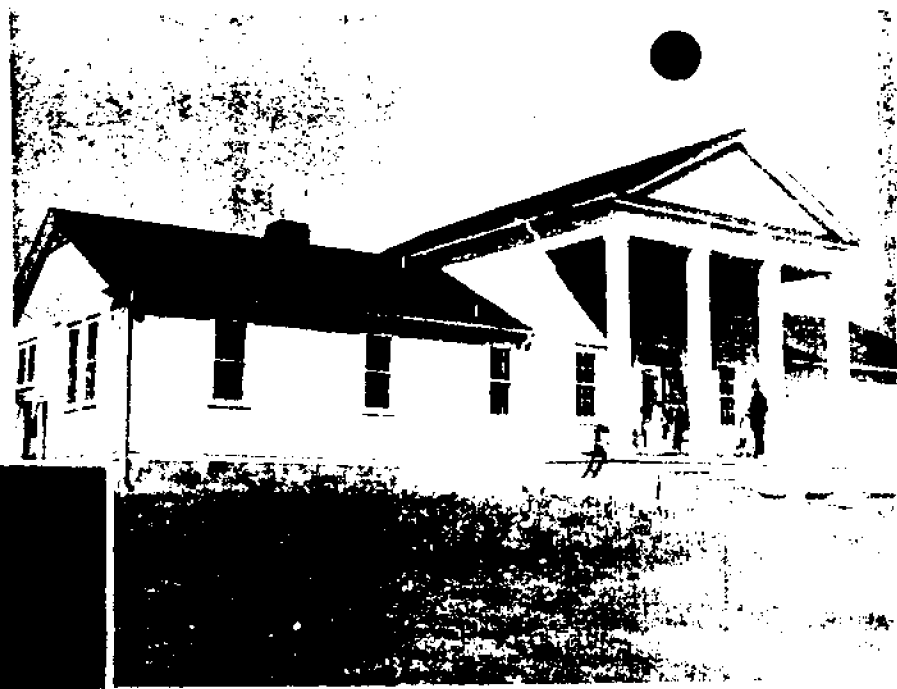

RED CROSS BUILDING

FINANCE BUILDING



BASKETBALL  
TEAM

CHRISTMAS AT THE CAMP POST OFFICE



1-2





CHOW ON THE RANGE

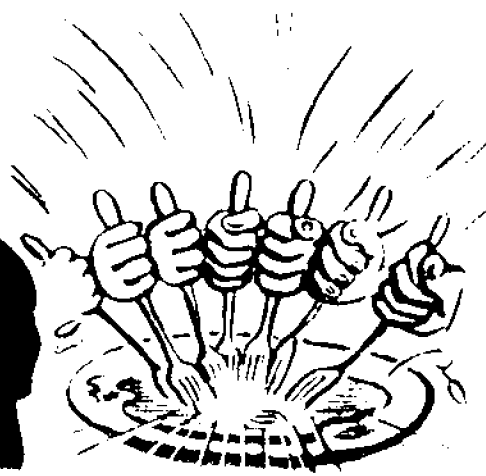

K-1

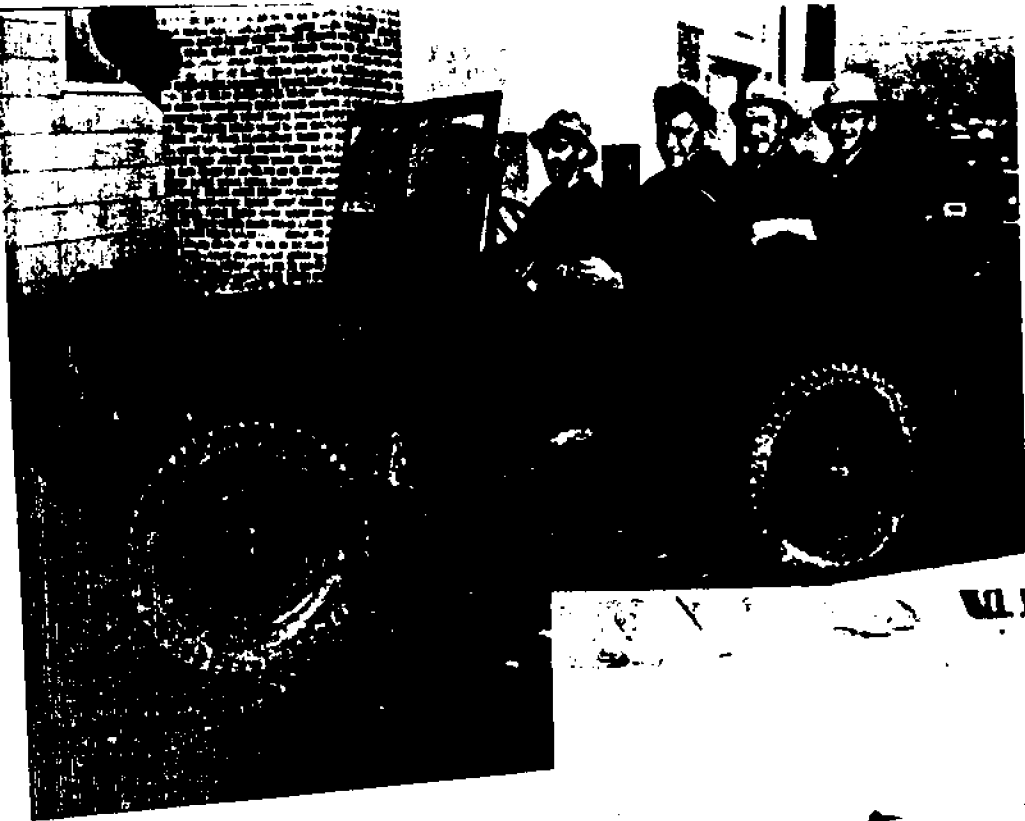

THE JEEP -  
WONDER CAR OF THE ARMY



FULL FIELD INSPECTION

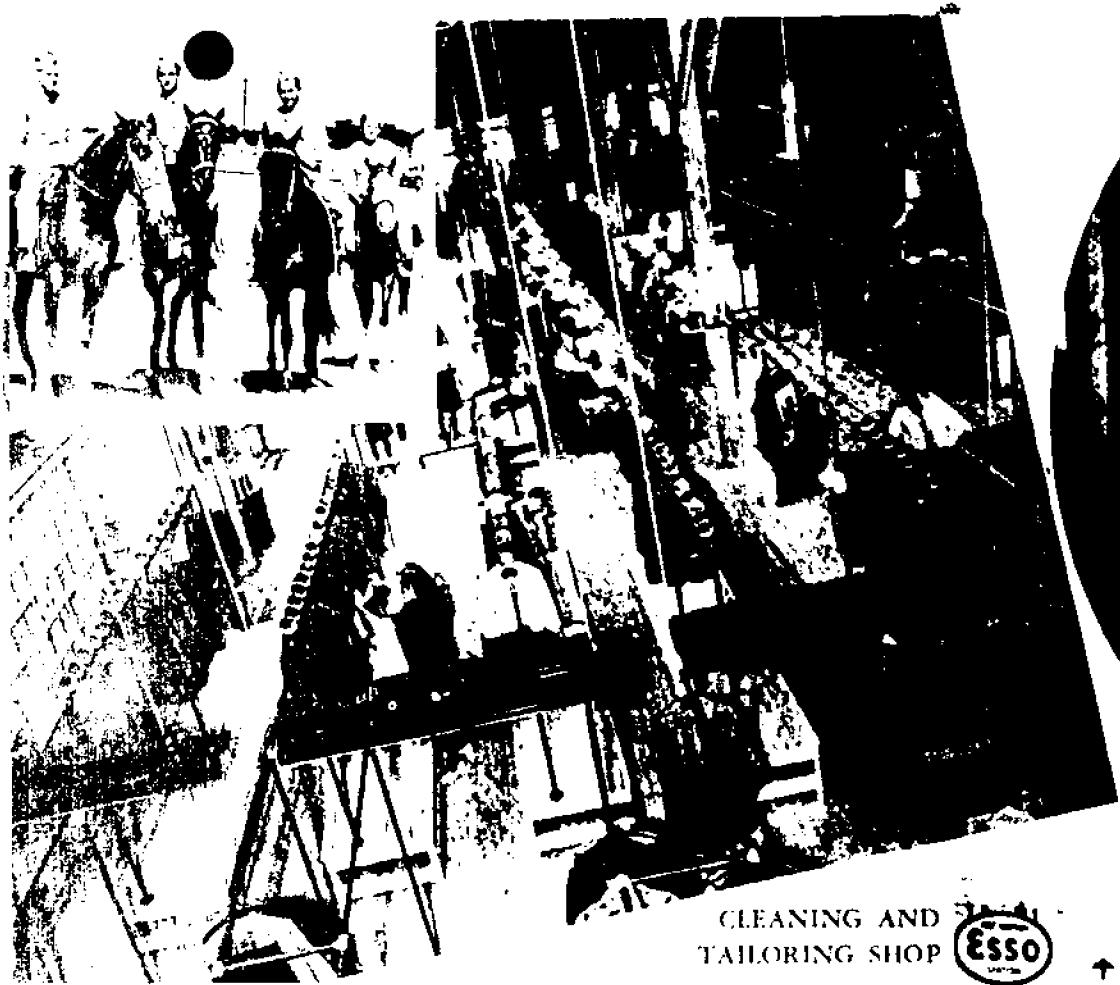

CLEANING AND TAILORING SHOP

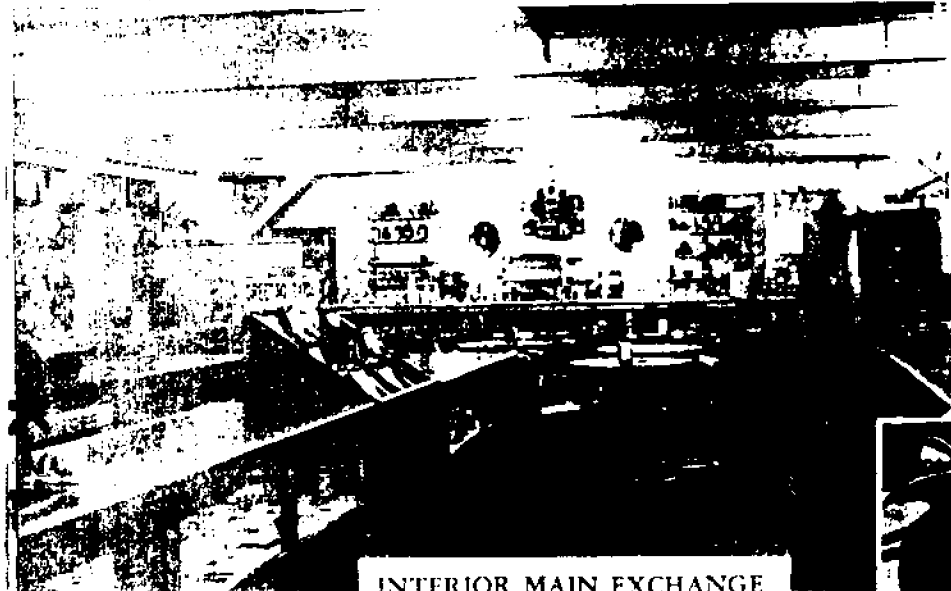

INTERIOR MAIN EXCHANGE



POST EXCHANGE

CAMP CROFT S.C.

POST OFFICE STORE NO. 2

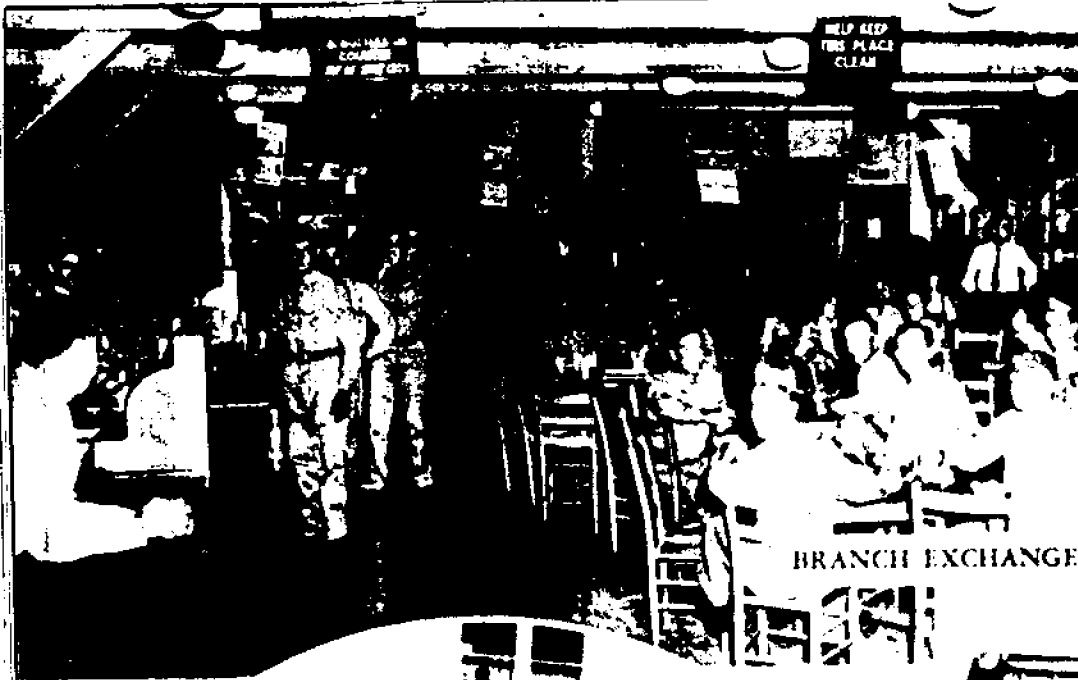

BRANCH EXCHANGE

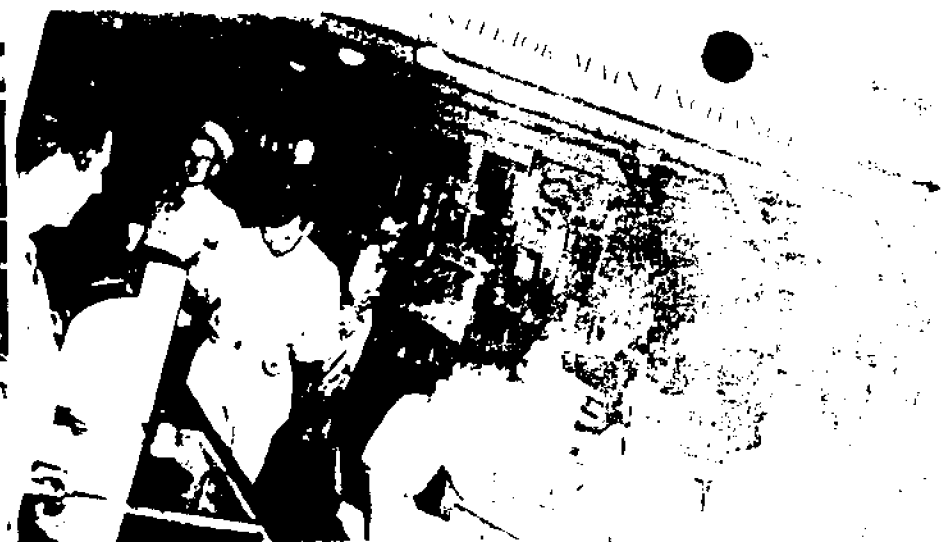

The Post Exchange comprises a Main Exchange, 6 branch exchanges, one in each regimental area; 2 sub-exchanges, one mobile store, 3 food stores, 2 ice cream sales trucks, all camp barber shops, a riding academy and a garage filling station. Each exchange carries a complete line of essentials, such as tobaccos, toilet articles, stationery, etc., and accepts coupons in lieu of money prior to pay day. The Tailor and Cleaning Shop is operated by the Croft Tailors and Cleaners, who are concessionaires of the Post Exchange. The Post exchange system is a cooperative enterprise in that its profits are returned to the men in the form of recreational and cultural activities.

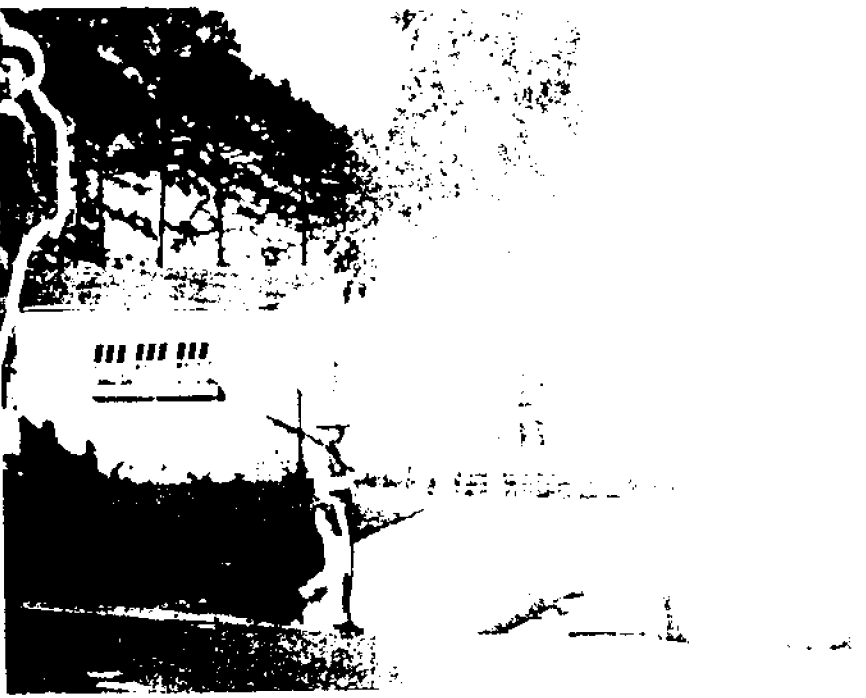

K-1

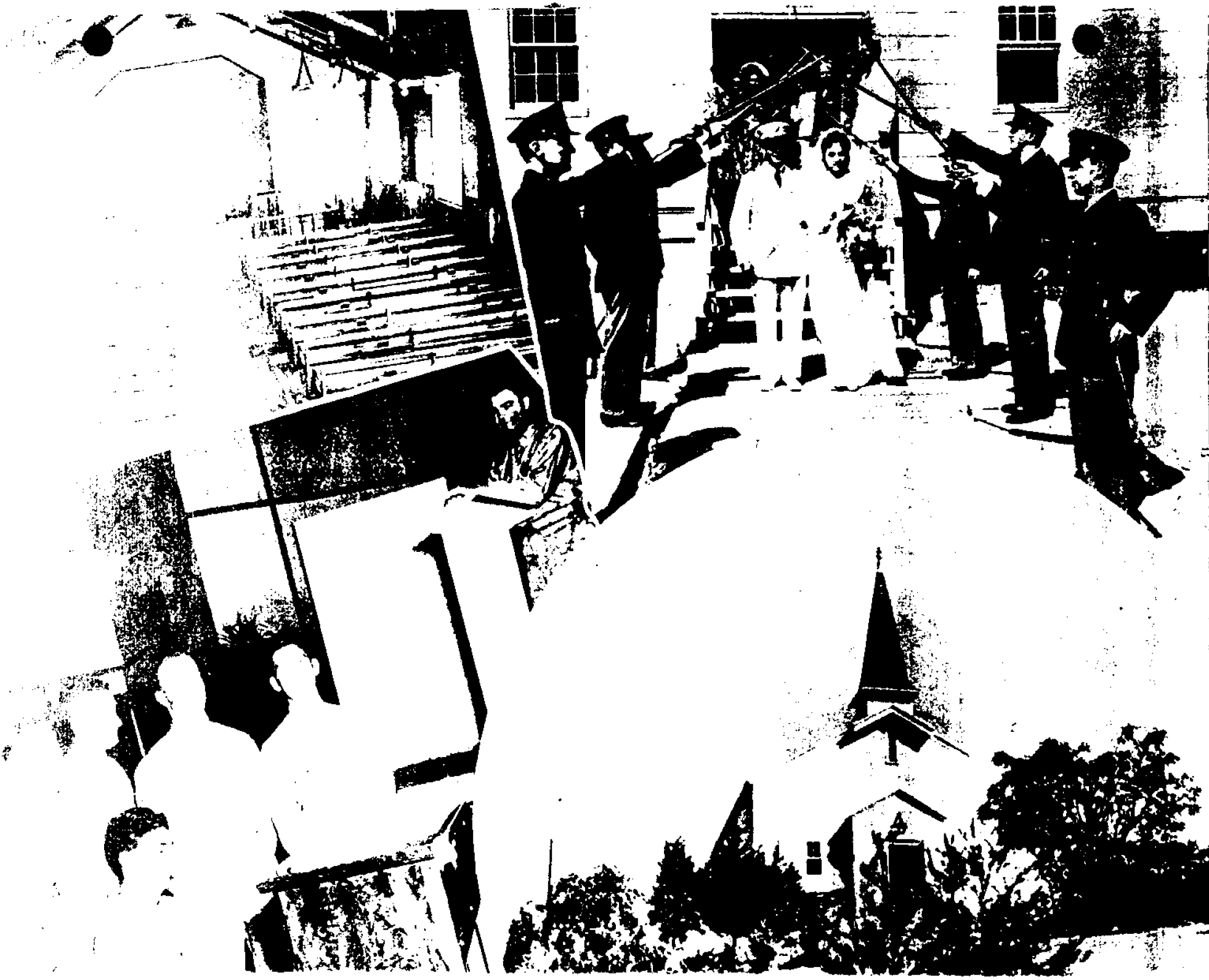



GLOOA

NO MAIL

MAIL CALL



BY DA





THE STATION HOSPITAL IS NEW AND ITS EQUIPMENT MODERN . . . THERE IS ALSO A DENTAL CLINIC AND PERIODIC DENTAL INSPECTION IS HELD TO DETERMINE THE NEEDS OF THE TRAINEES . . . THE MEDICAL CORPS TAKES EVERY PRECAUTION AGAINST INJURY AND DISEASE . . . COMPANY COMMANDERS AND THEIR OFFICERS LAY PARTICULAR STRESS ON THIS POINT.

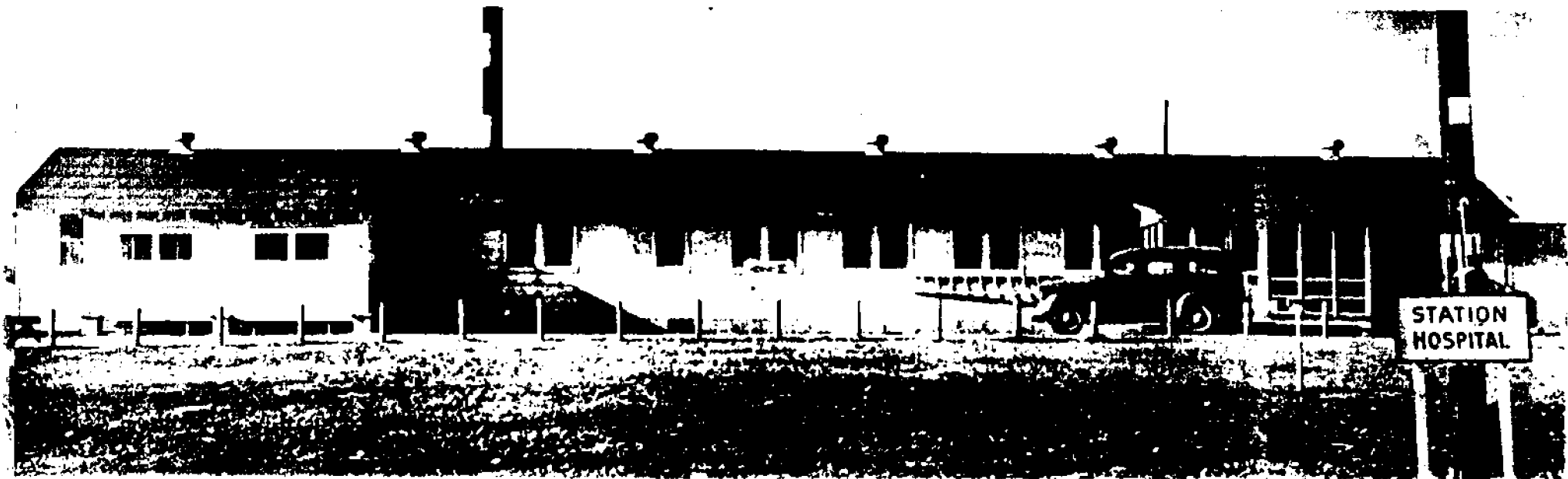

JACK DEMPSEY VISITS CAMP

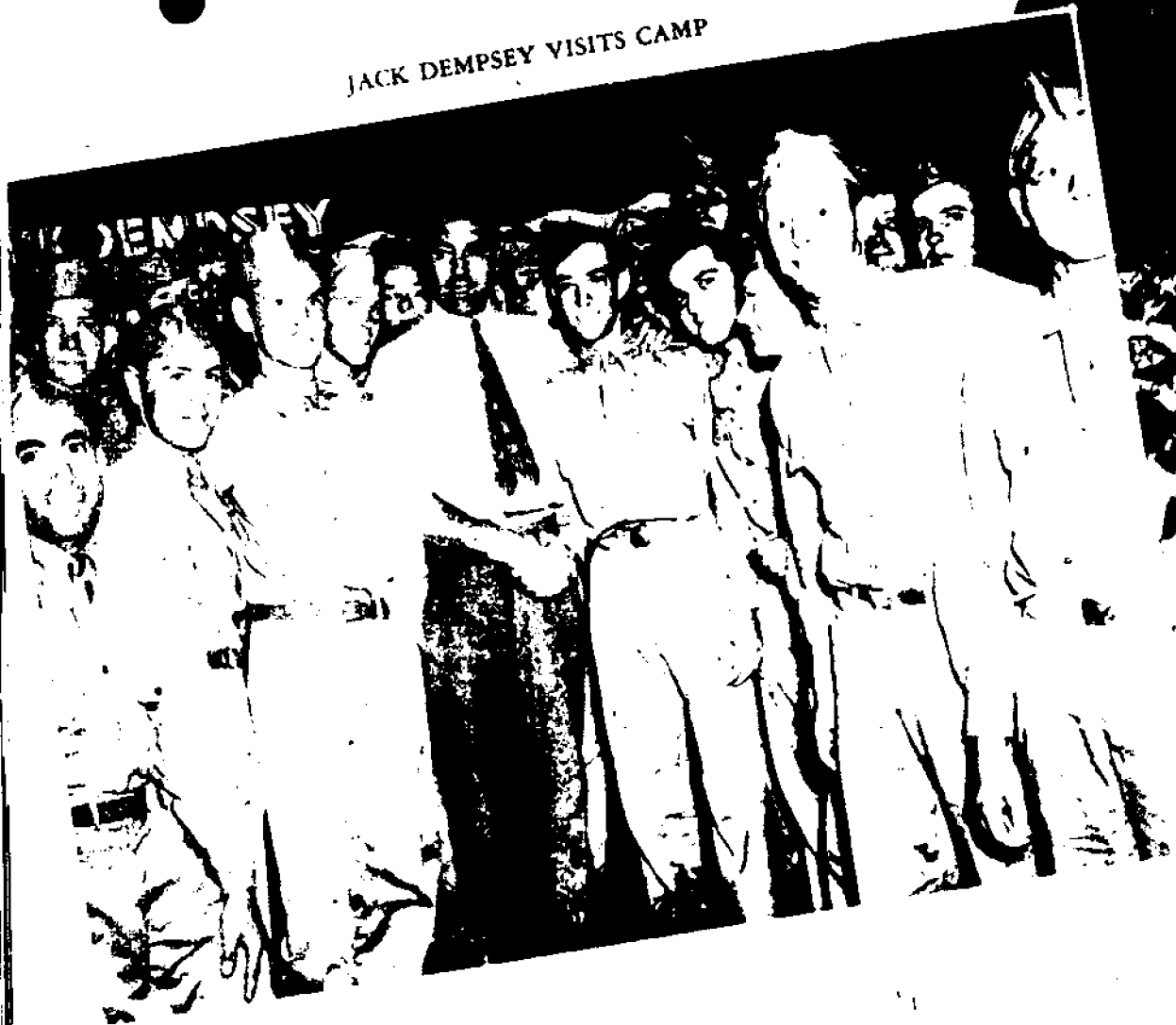

MOBILE SHOW

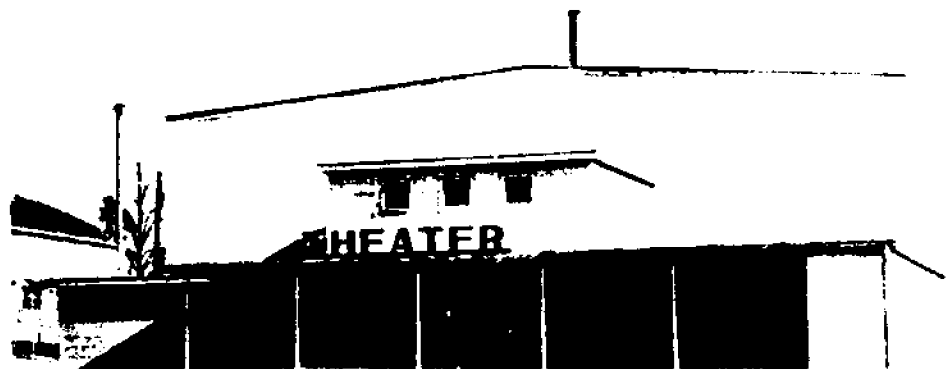

Camp has four modern Theatres. Pictures change three times weekly . . . Admission free, but coupon books.





K. P. DUTY

Trainee's wife, relatives, and friends may visit him at camp and stay in the guest house at a nominal cost. Fifty cents per person nightly.

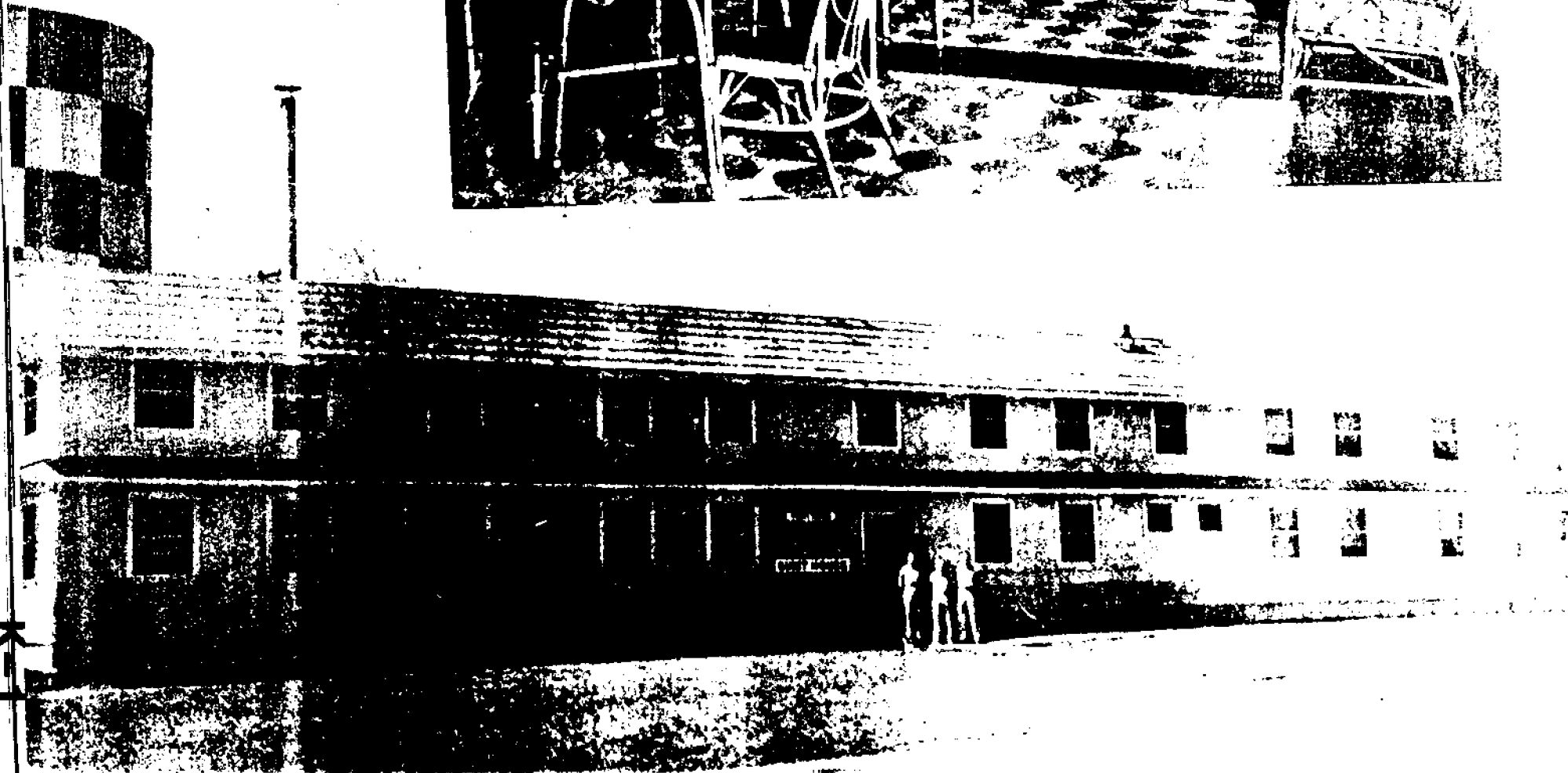
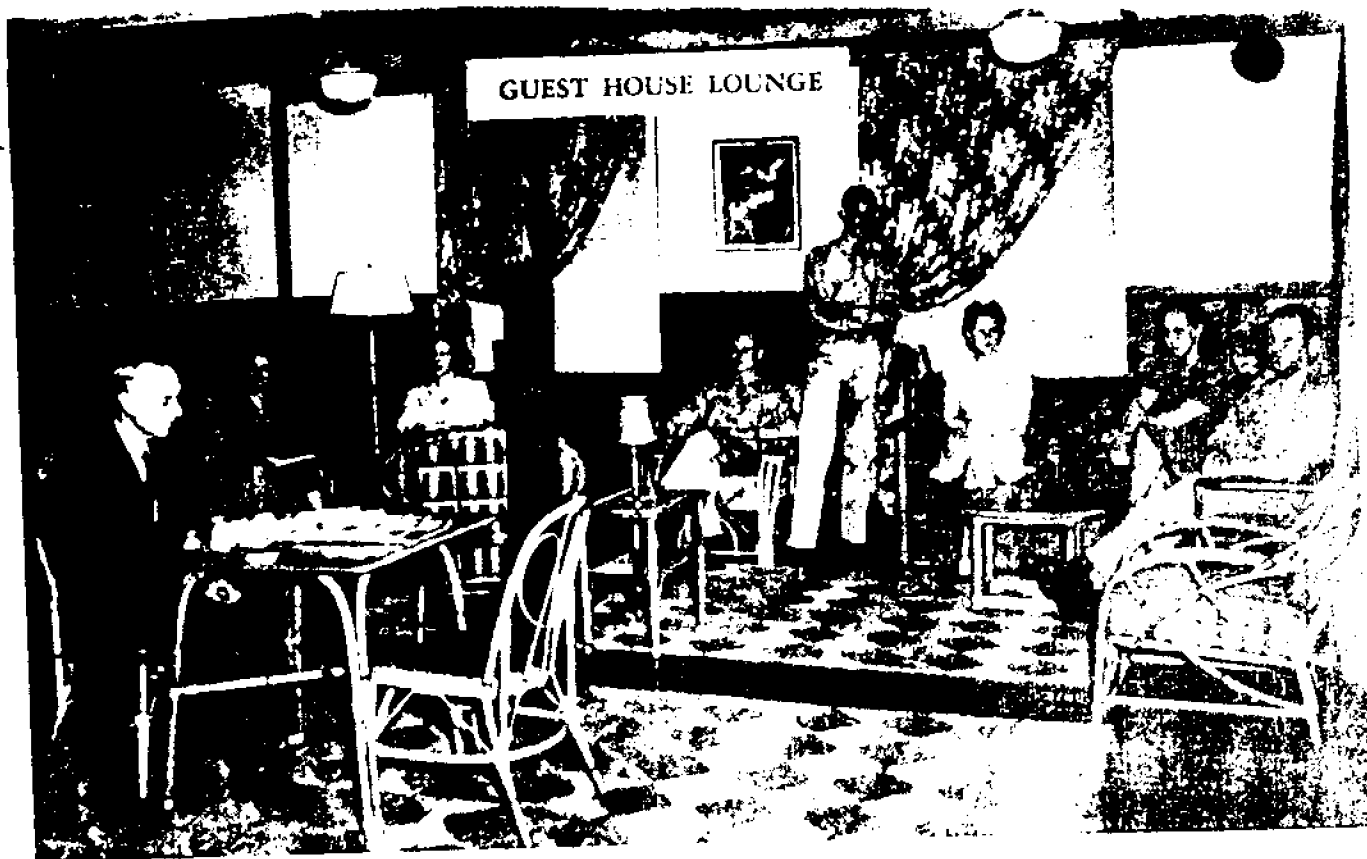



SERVICE CLUB DANCE

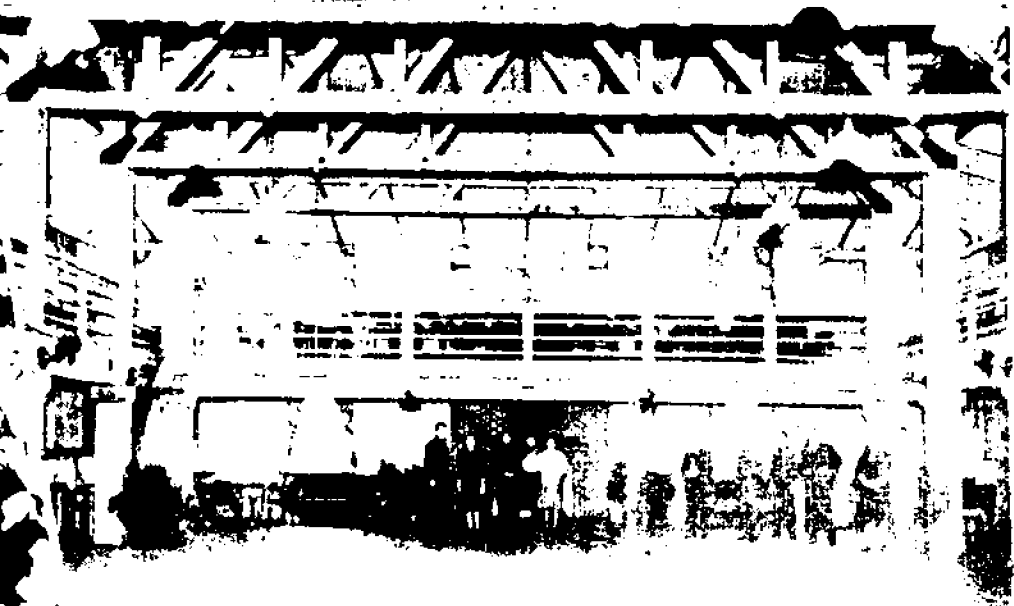

INTERIOR SERVICE CLUB



INTERMISSION  
REFRESHMENTS



CAMP

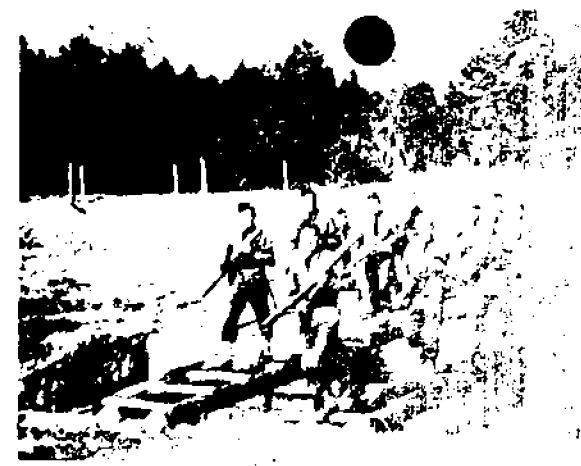

CROFT

OBSTACLE COURSE



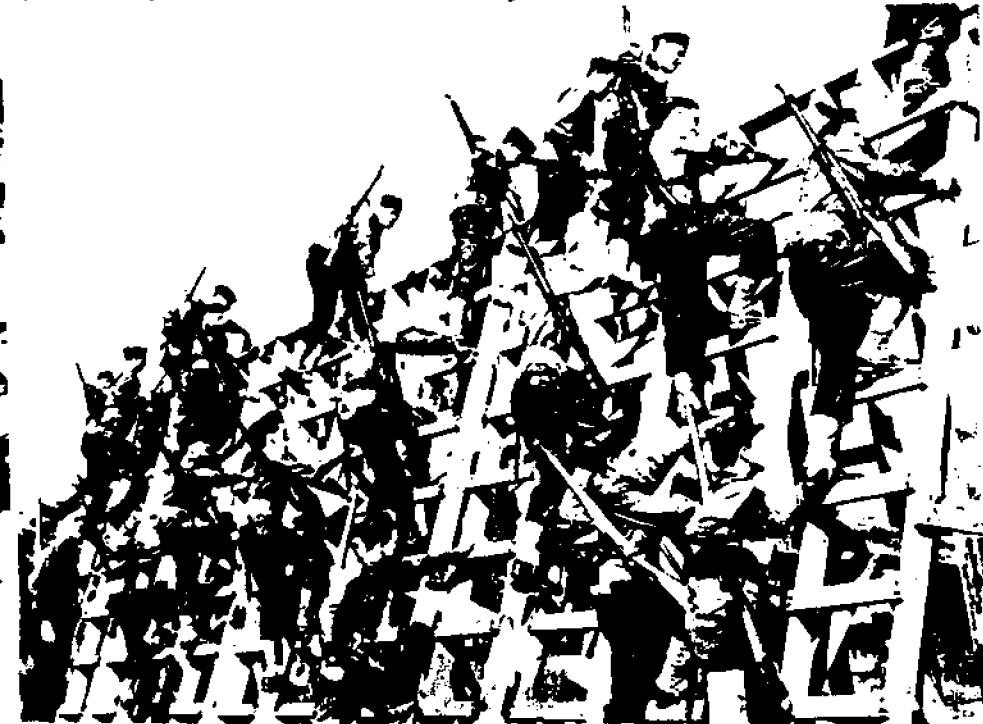

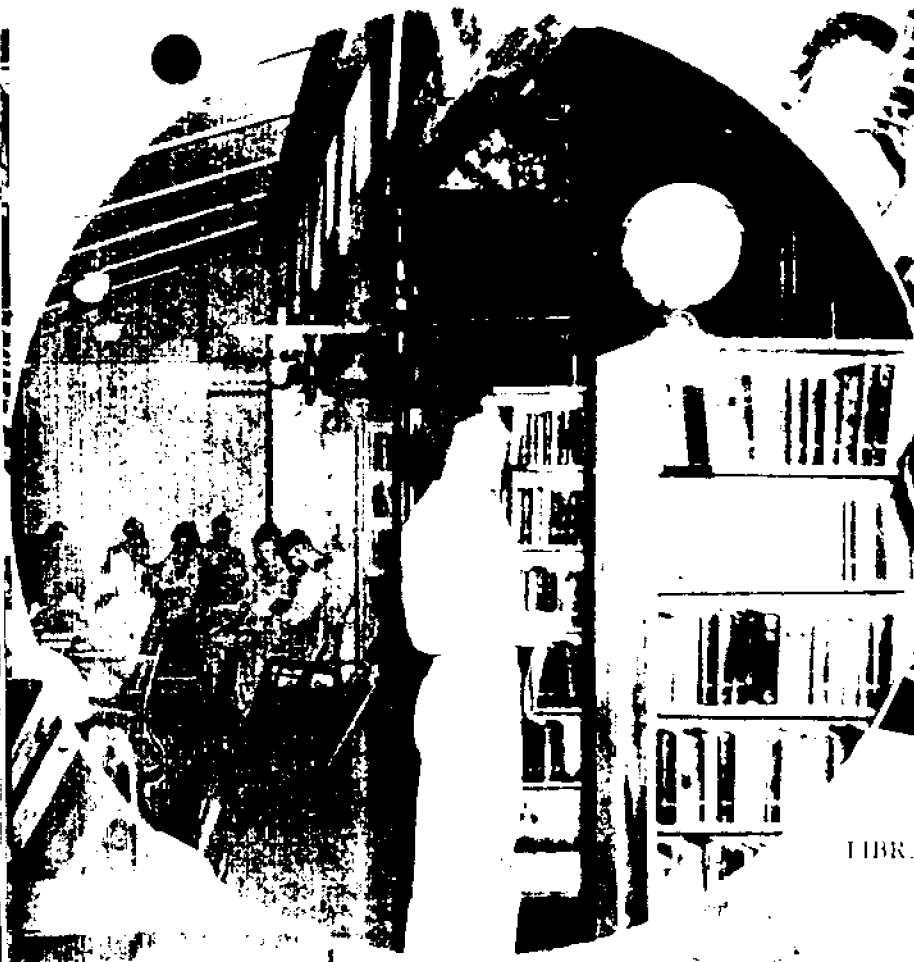

LIBRARY



CAMP ORCHESTRA



SERVICE CLUB  
GALLERY



EXISTED MEN'S  
SERVICE CLUB



GAS DRILL  
AND INSTRUCTION

K-17

GAS CHAMBER NO. 2



K-1



WAITING FOR  
CHOW



WAITING FOR  
MESS HALL

K-1

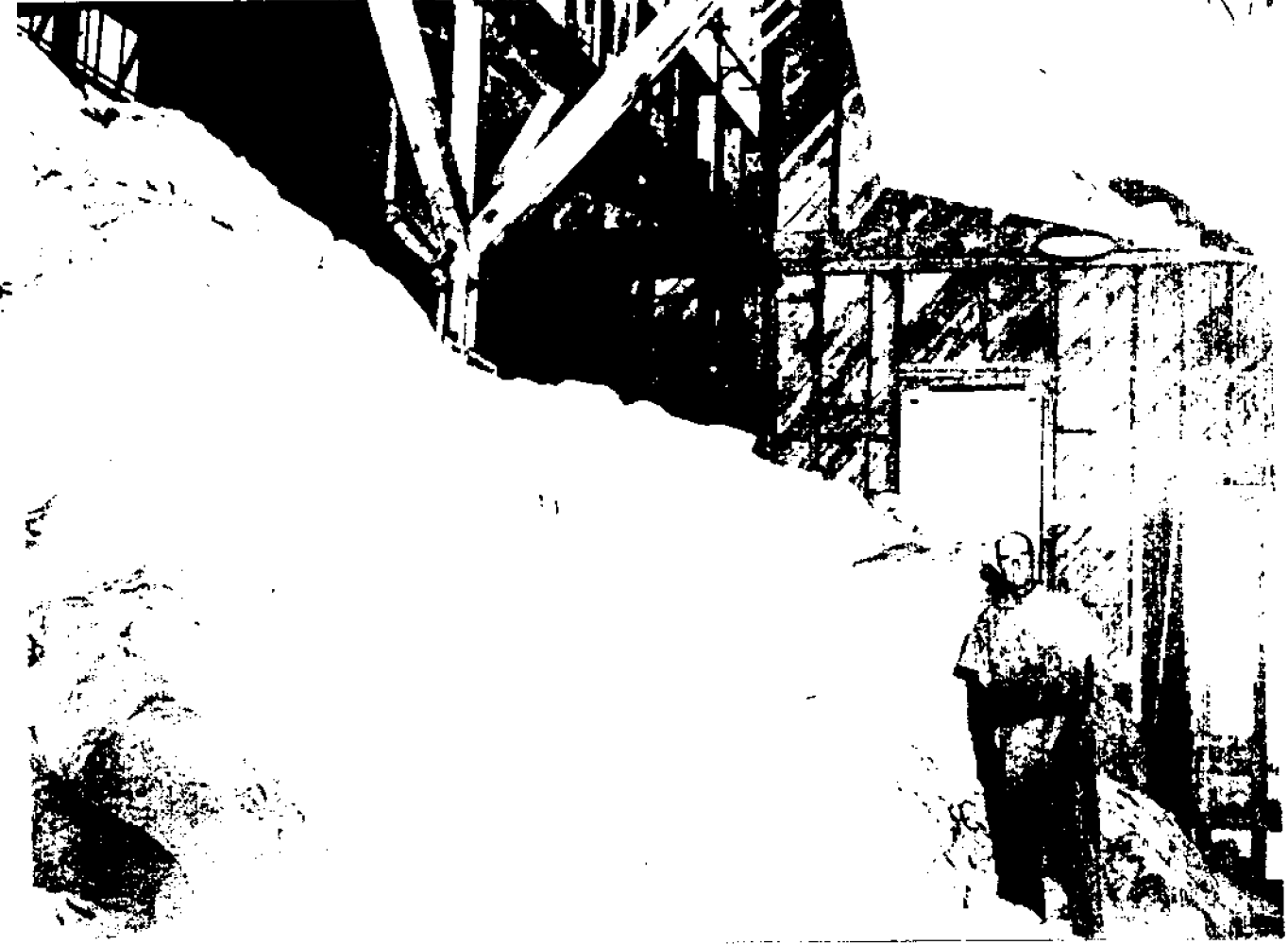

LAUNDRY

K-1



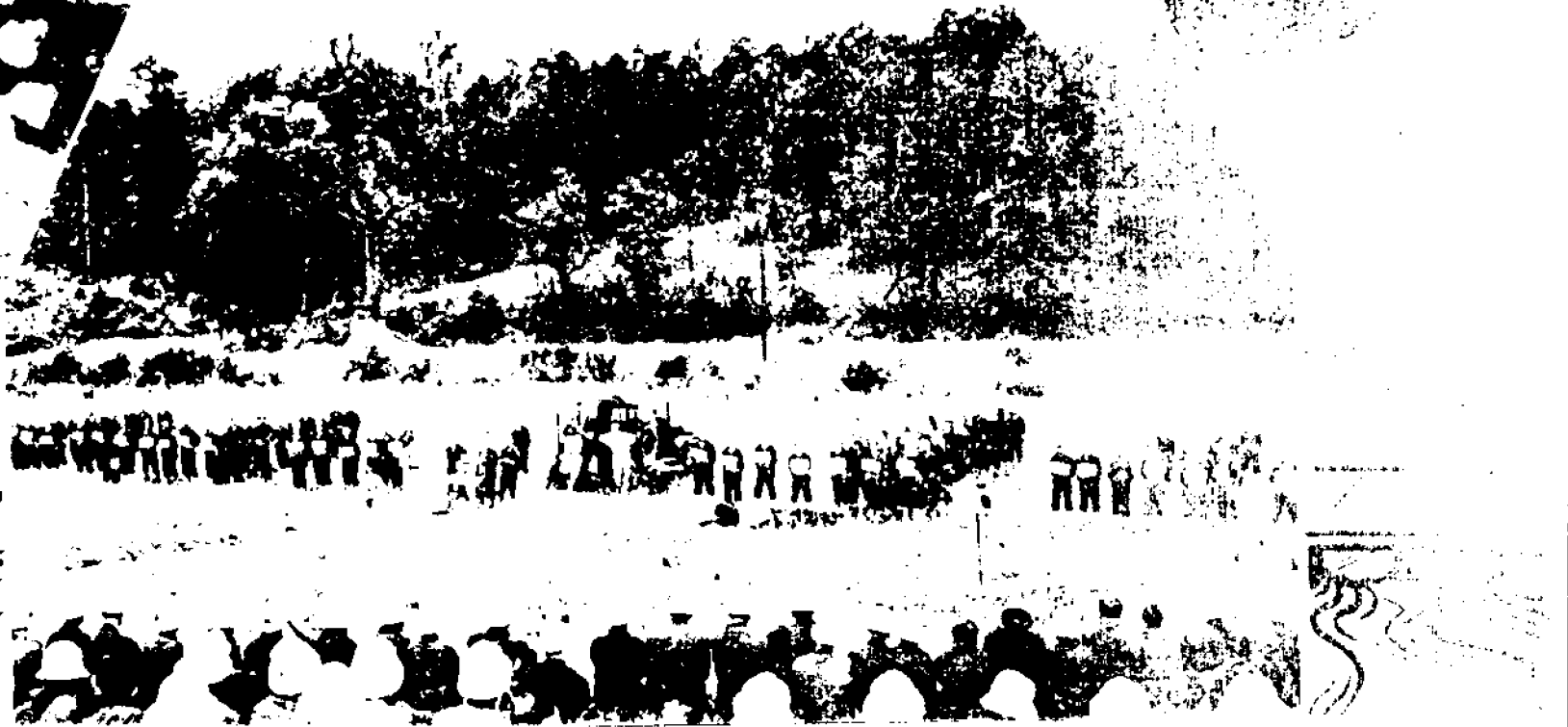



OFFICERS' LOUNGE



OFFICERS' QUARTERS

OFFICERS' QUARTERS

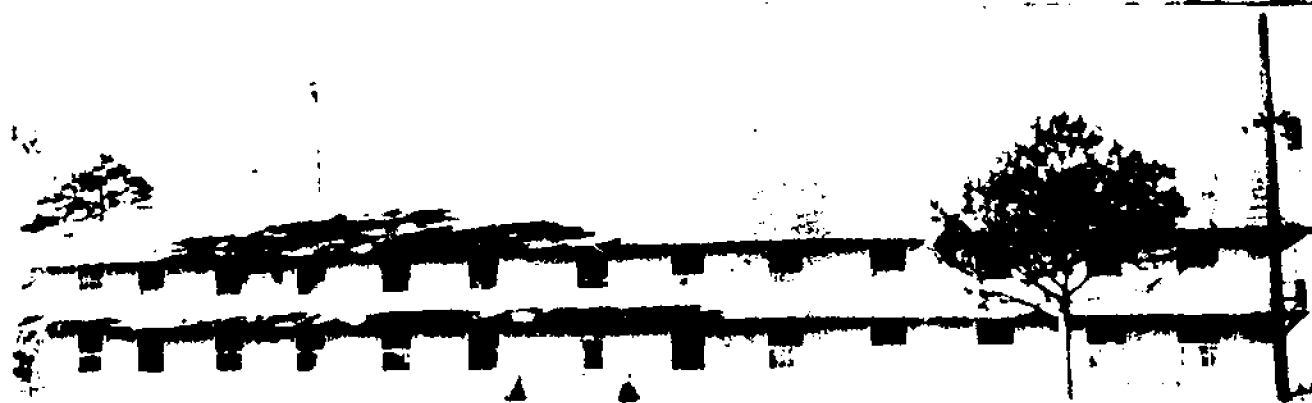

Officers Quarters  
OFFICERS' QUARTERS



BAYONET DRILL



STACKED ARMS

PASSING  
REVIEW





RECREATION

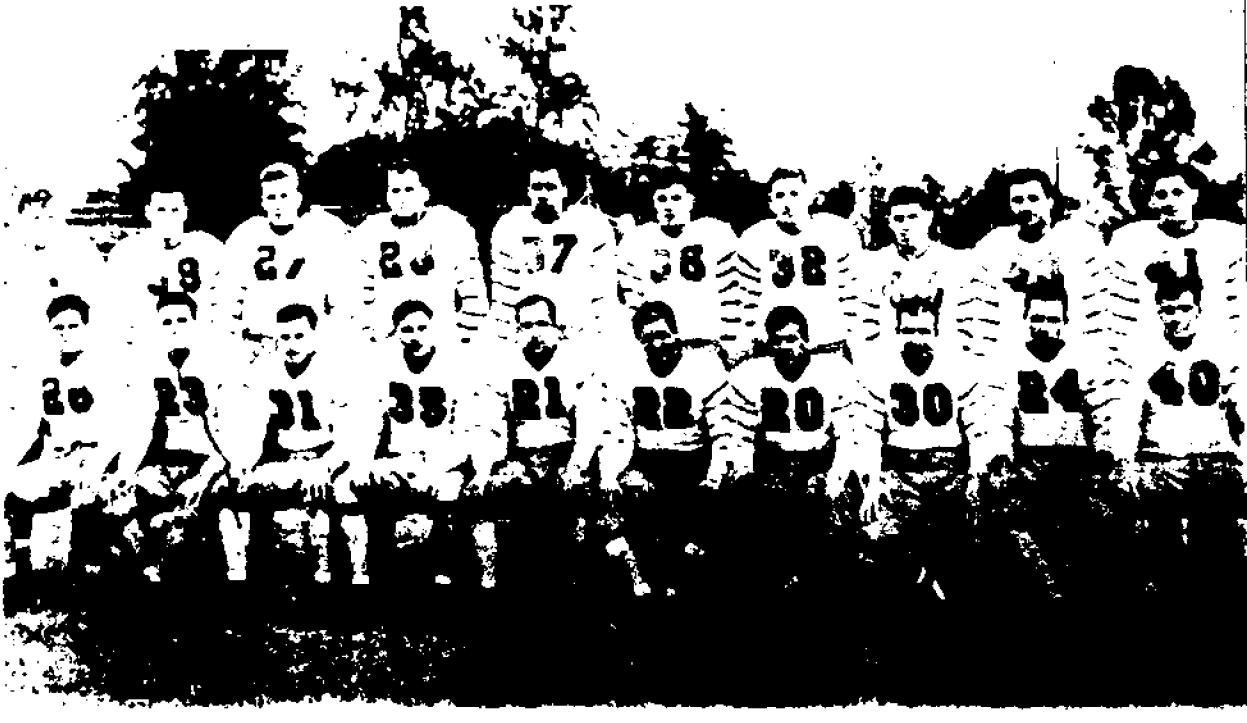

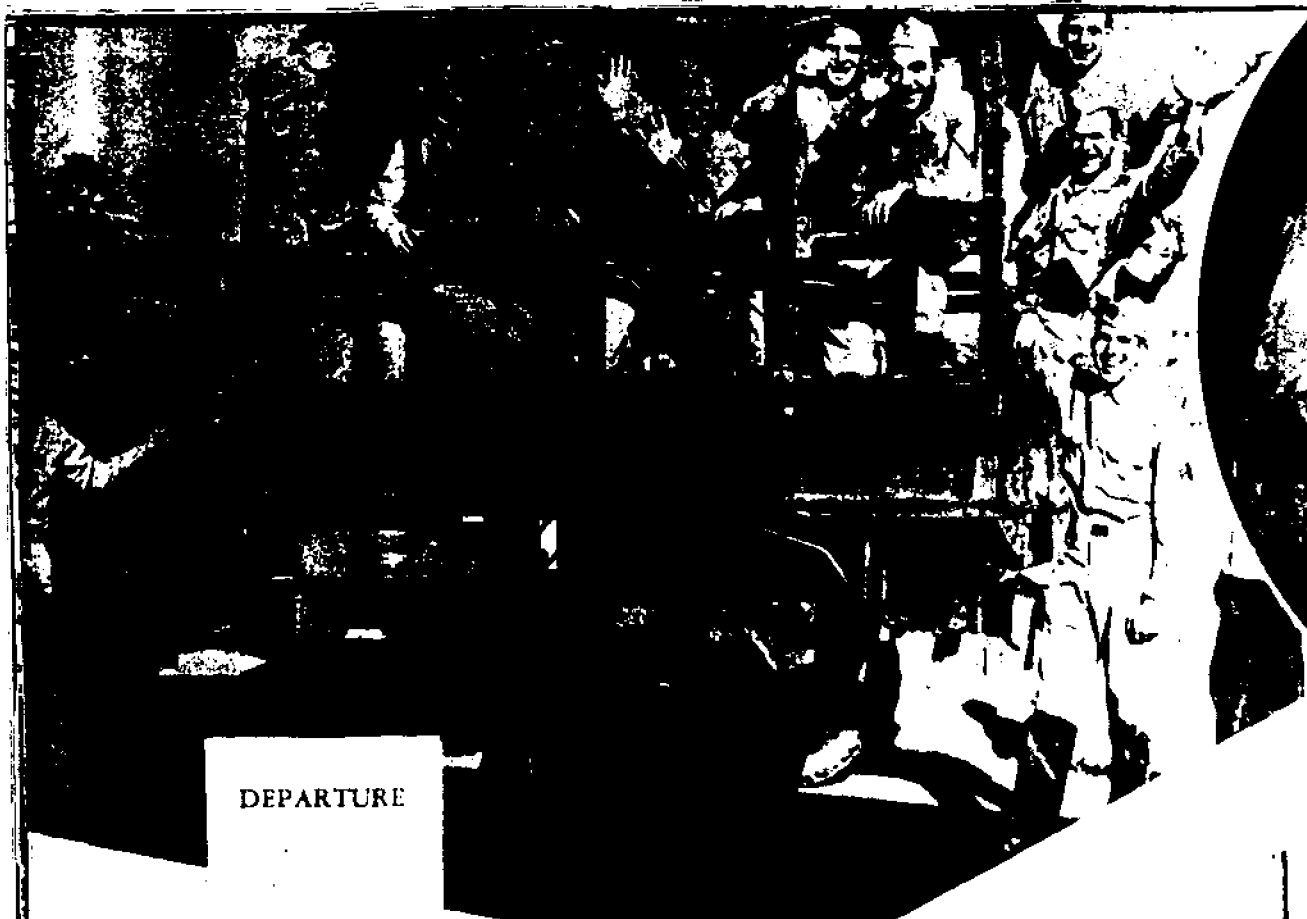

DEPARTURE



MOTOR POOL

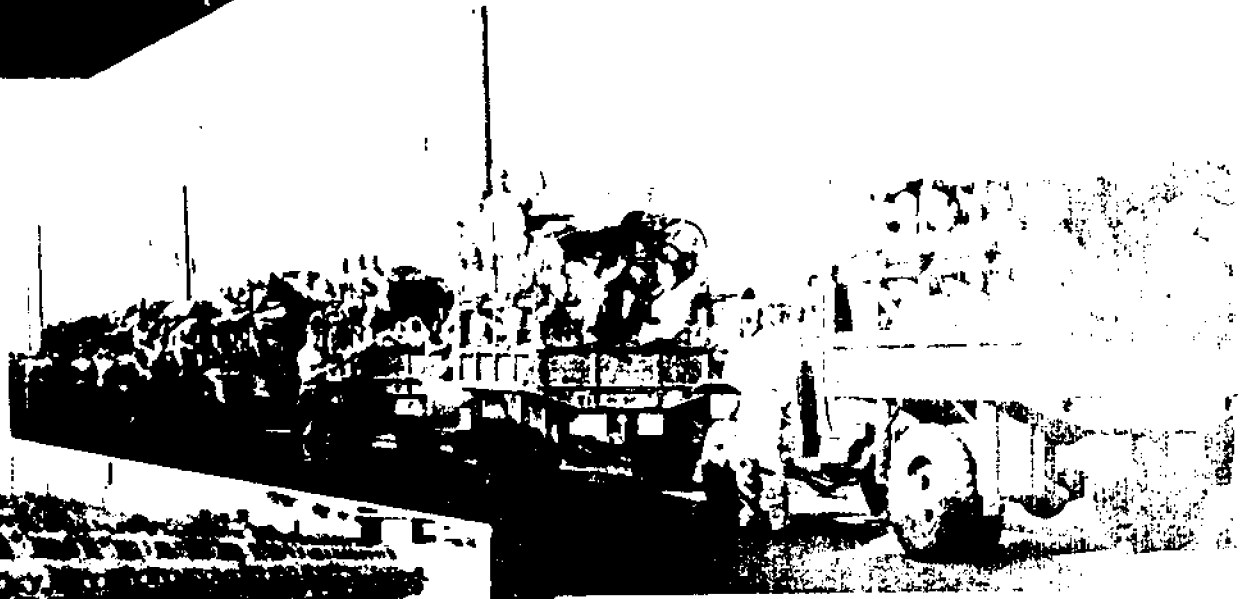
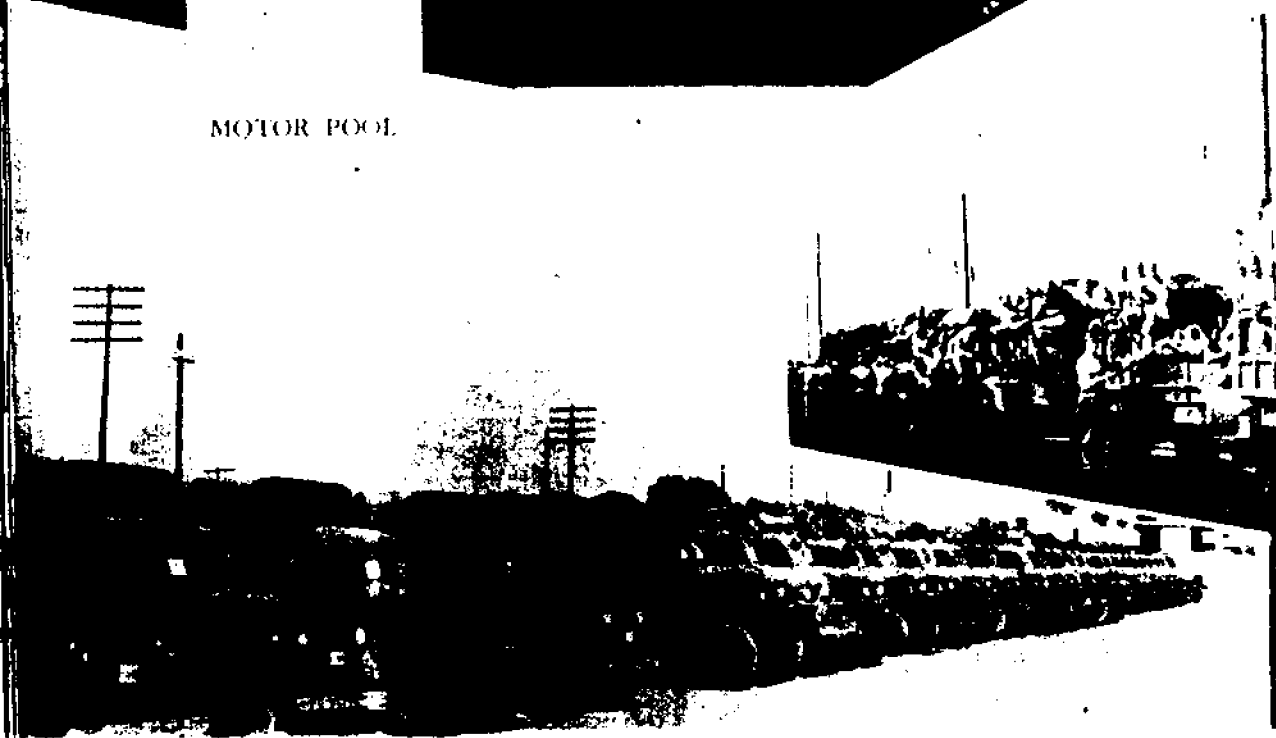

CONVOYS TAKING TRAINEES  
TO PERMANENT POSITS





CLASS  
INSTRUCTION





DENTAL CLINIC  
AND  
DENTAL CARE



ANTHELMINTIC  
SHOTS

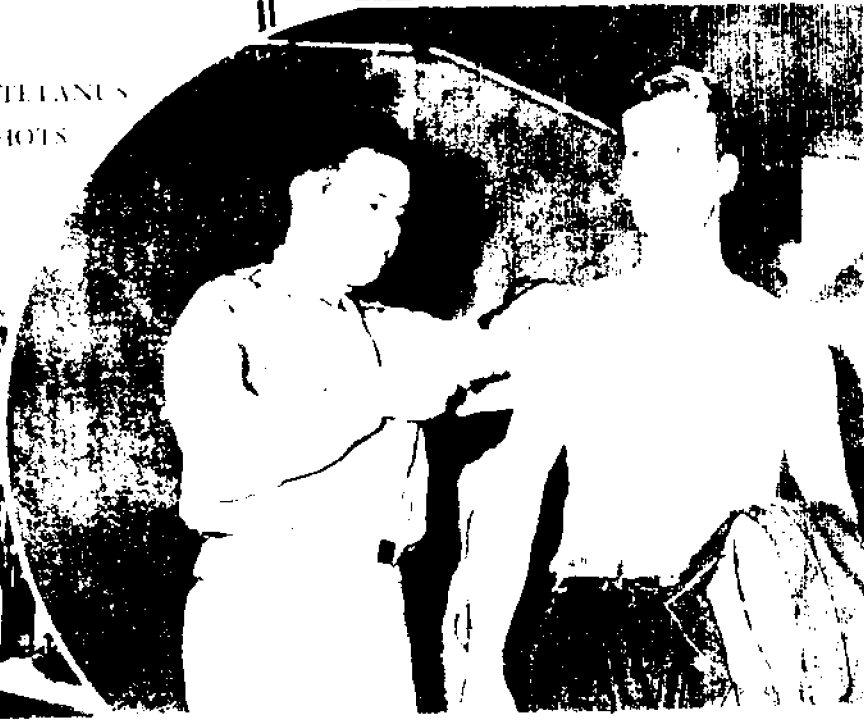



INSTRUCTION ON THE RANGE

K-11



IN THE TARGET PITS



K-1

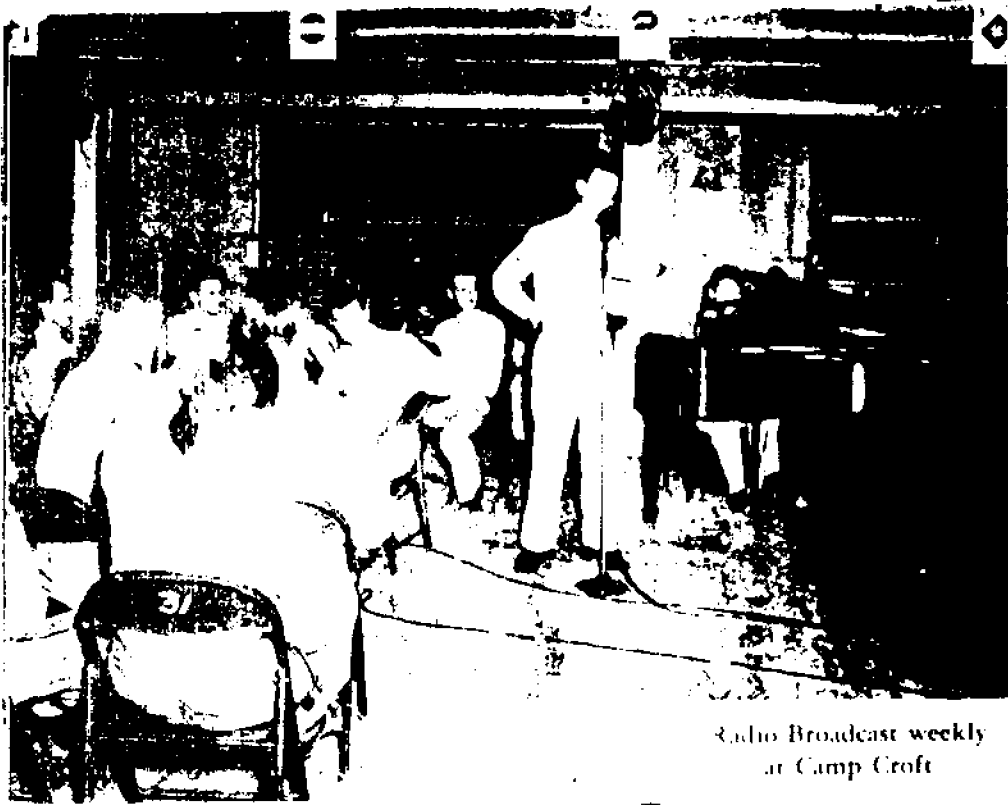

Radio Broadcast weekly  
at Camp Croft



Santa Visits Men of 35th  
Batallion Christmas



Mess Hall at  
Station Hospital



Waiting for that Christmas  
Dinner at the Mess Hall at  
36th Batallion Company B

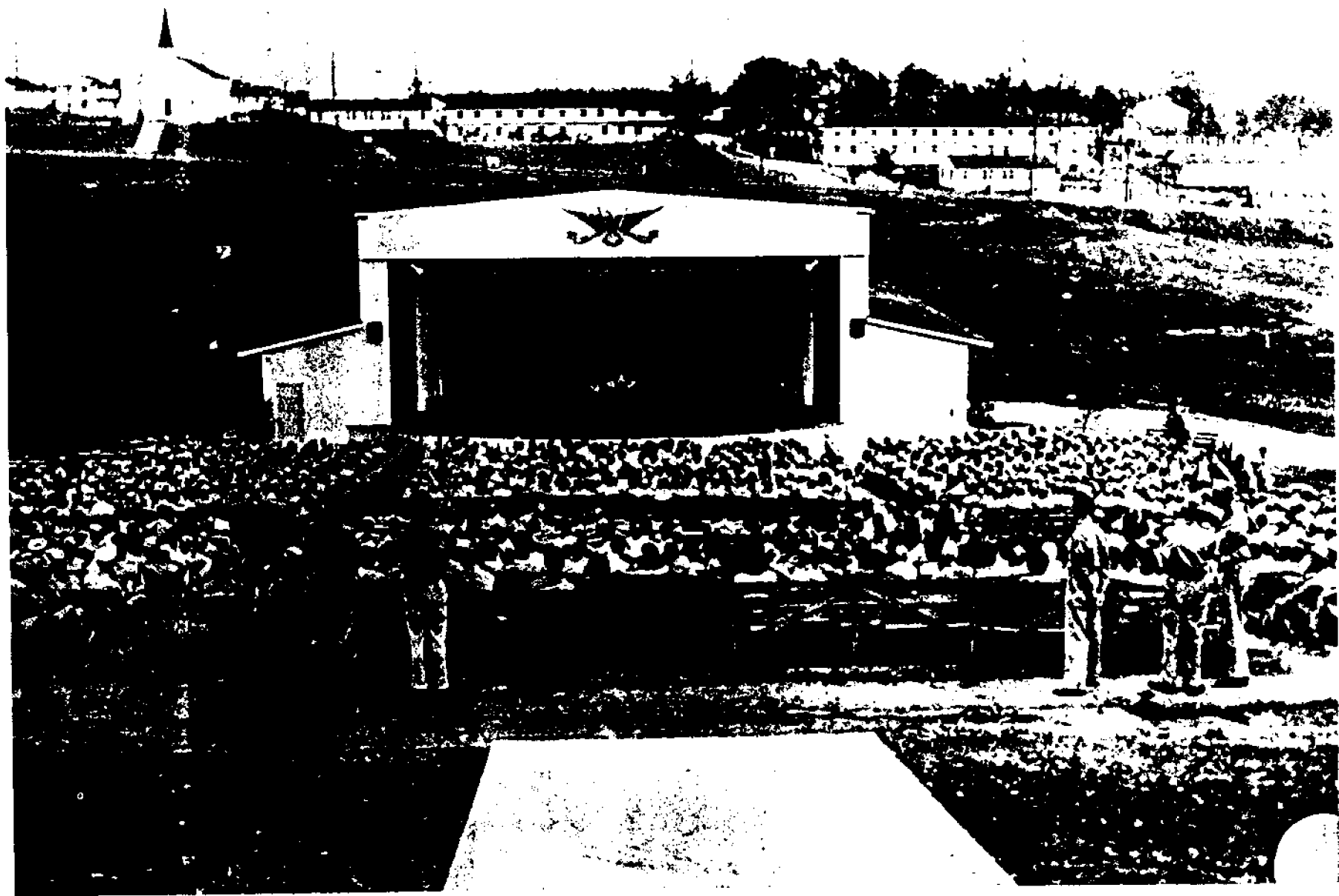

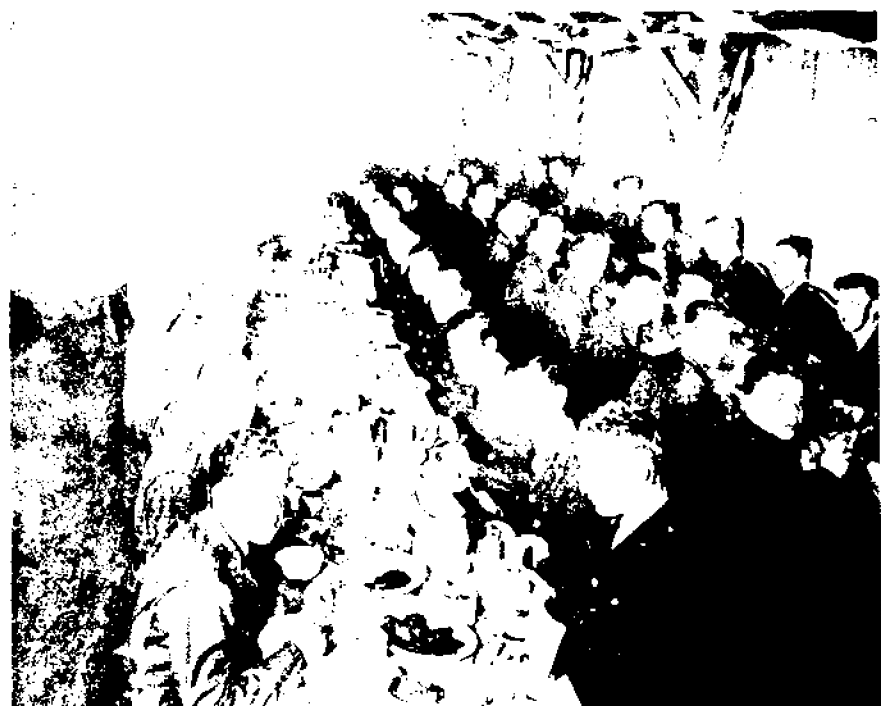
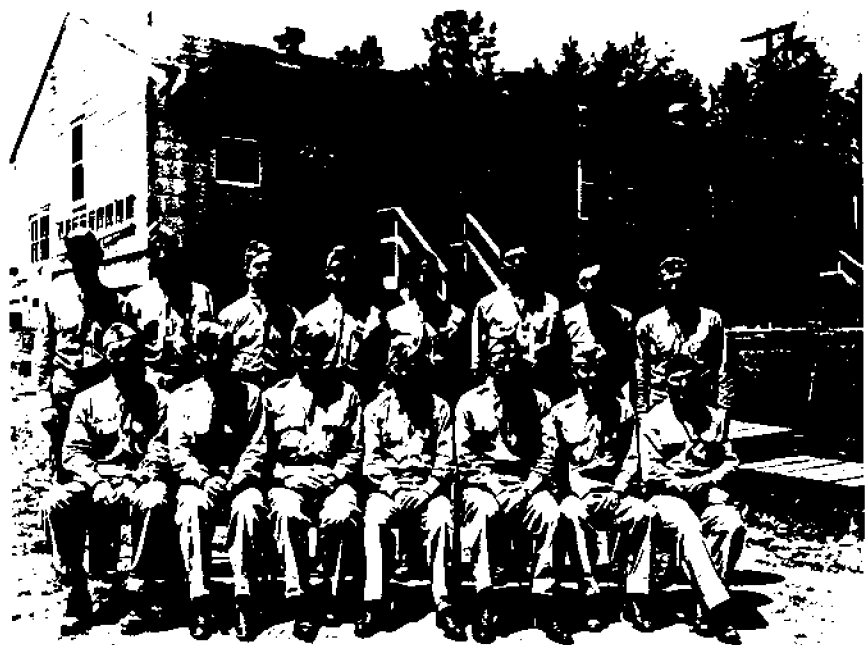

K-1



K-1





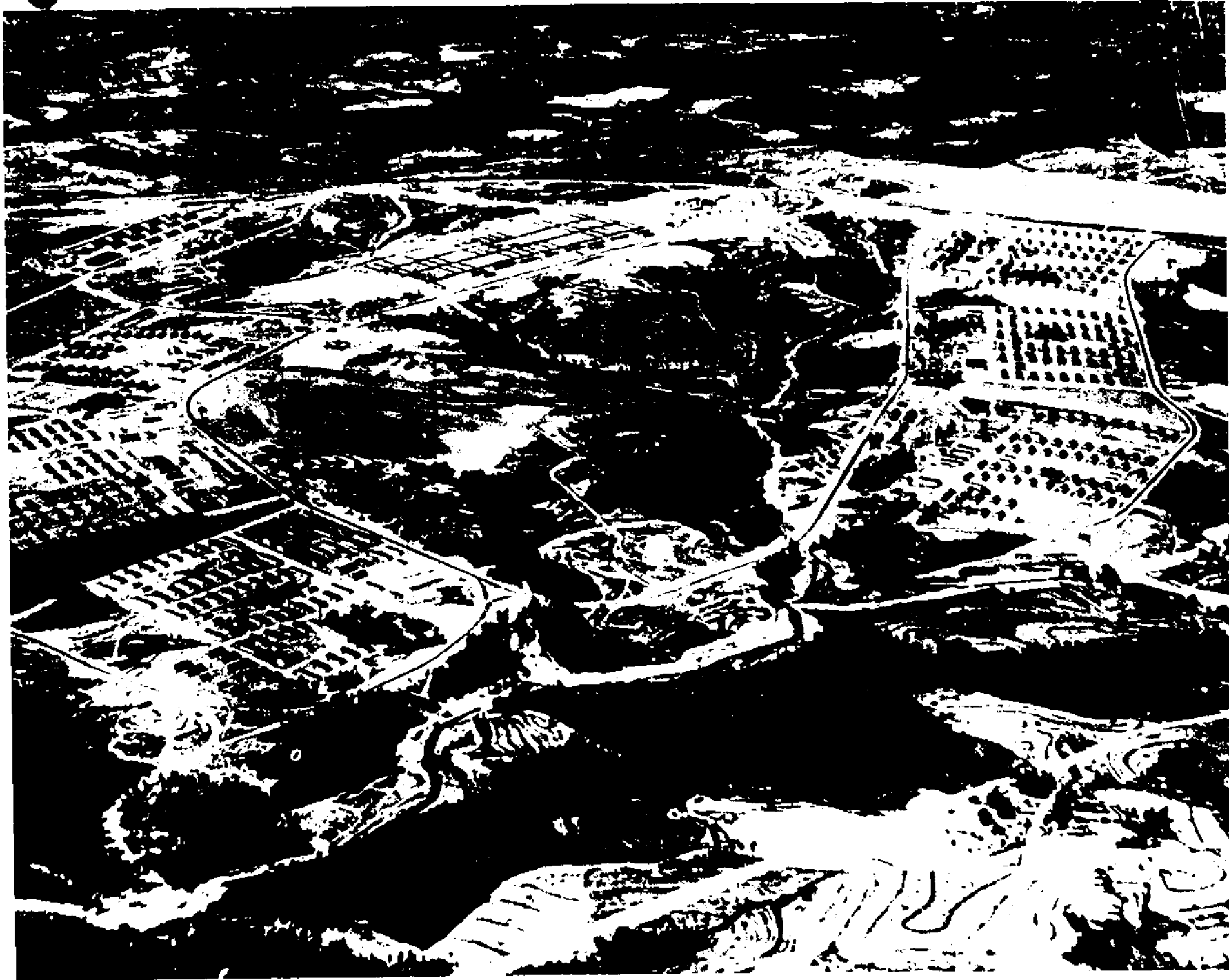



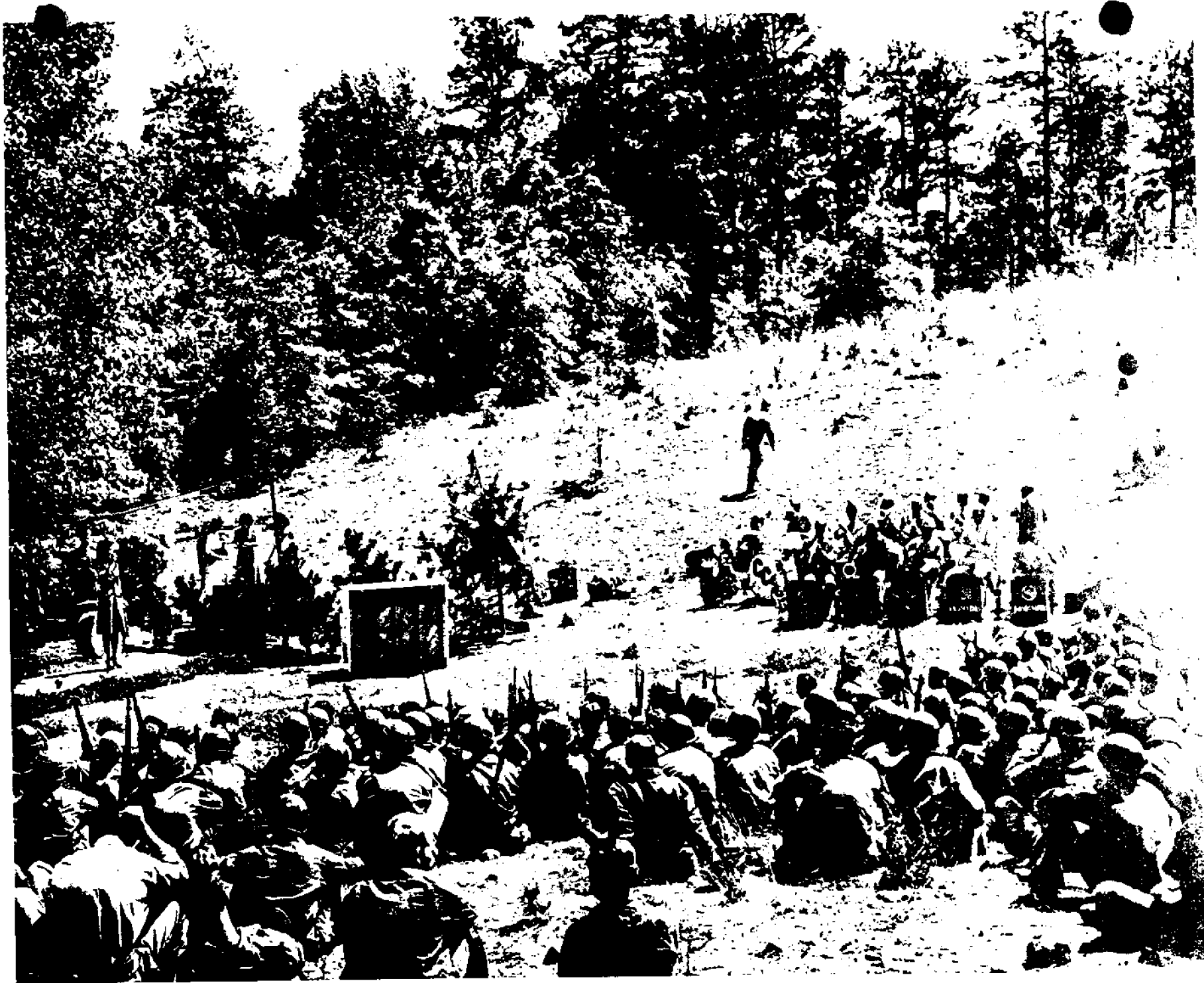

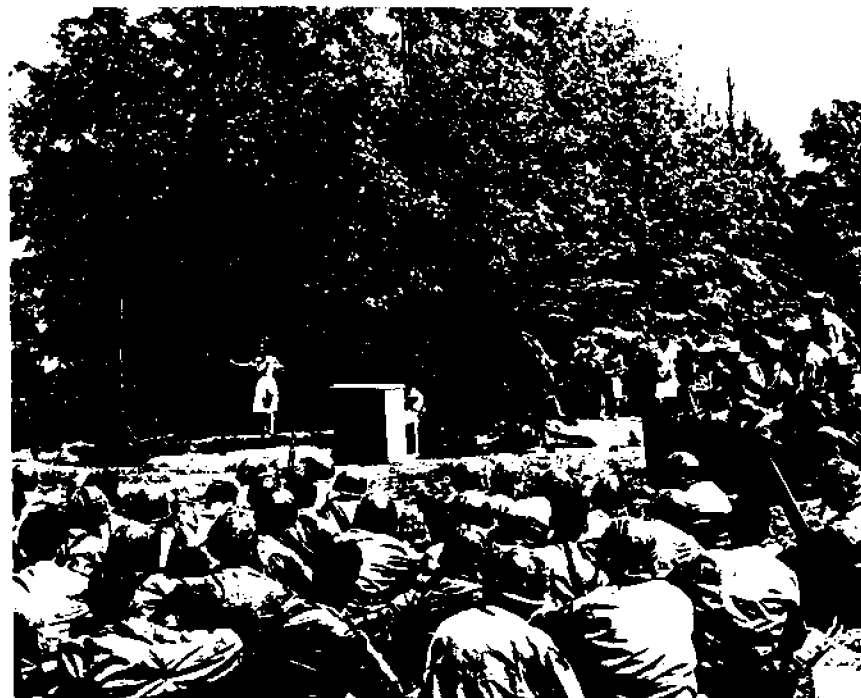

K-1



St. Luke United Methodist Church and The 50th Anniversary Committee would like to thank the Spartanburg County Foundation and the following firms who helped to make this Celebration possible:

AMERICAN FEDERAL BANK  
AMOCO OIL CO./SPARTANBURG  
BLACKMAN UHLER CO.  
BROOKWOOD FARMS  
C & S NATIONAL BANK  
CIRCLE EXXON STATION  
COCA-COLA OF SPARTANBURG  
COLONIAL PIPE LINES  
CROWN CENTRAL/FAST FARE  
FIRST FEDERAL OF SPARTANBURG  
FRITO LAY INC.  
GILL DRILLING SERVICES INC.  
HARLEY INVESTMENTS  
INGLES  
KENNEDY STREET FLORIST  
MASTER MACHINE WORKS  
MAYFAIR MILLS  
MILLIKEN & COMPANY  
PINE STREET EXXON  
PRECISION CUTTING  
SPARTANBURG NATIONAL BANK  
TOWE AGENCY  
TWIN OAKS EXXON  
VAN WATERS AND ROGERS, INC.  
WAKEFIELD BUICK  
WALDENSIAN BAKERY

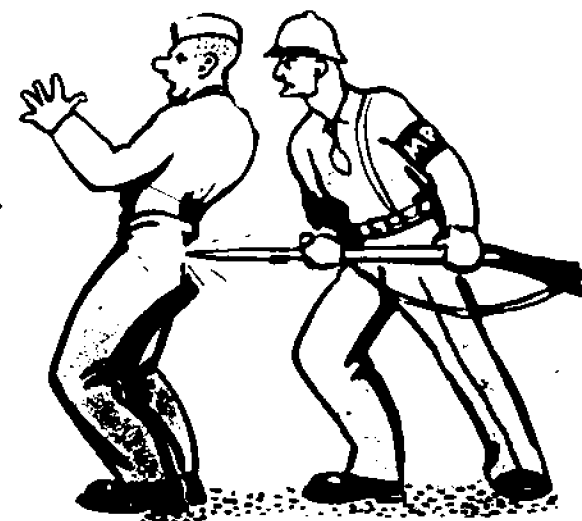
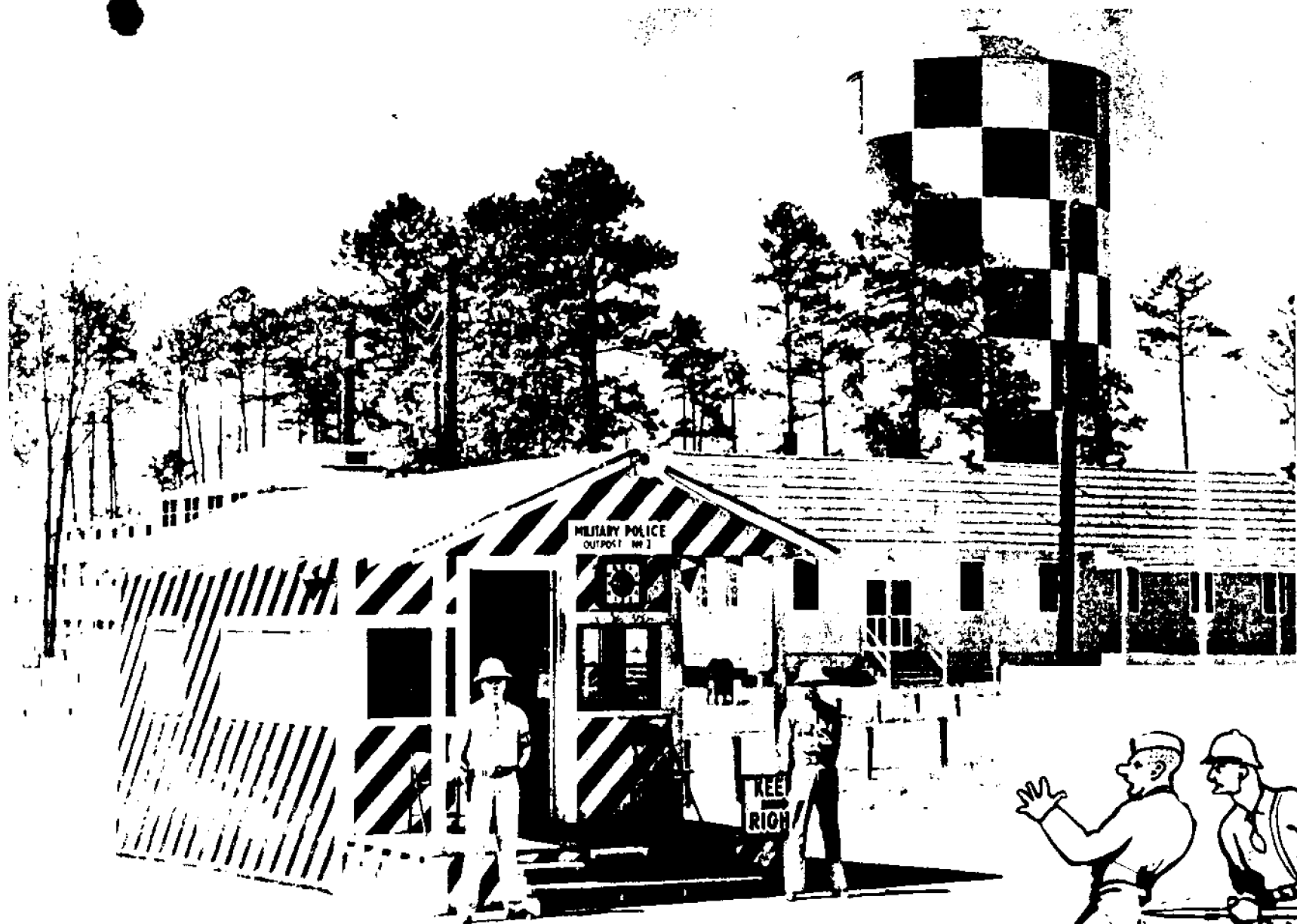

CAMP CROFT, ONE OF THE NATION'S LEADING INFANTRY REPLACEMENT TRAINING CENTERS, IS NAMED IN HONOR OF THE LATE MAJOR GENERAL EDWARD CROFT . . . IS SITUATED FIVE MILES SOUTHEAST OF SPARTANBURG, S. C., ON STATE HIGHWAY NO. 9 . . . OCCUPIES 18,000 ACRES AND IS STILL GROWING . . . HAS 674 BUILDINGS WITH MORE UNDER CONSTRUCTION . . . HAS A TOTAL COMPLEMENT OF 18,000 MEN AND ACCOMMODATES 16 BATTALIONS . . . DOCTORS, LAWYERS, TRUCK DRIVERS, ARTISTS . . . MEN FROM ALL WALKS OF LIFE . . . APPROXIMATELY 65,000 WILL PASS THROUGH CAMP ANNUALLY AND BECOME BUDDIES FOR THE THIRTEEN-WEEK TRAINING PERIOD



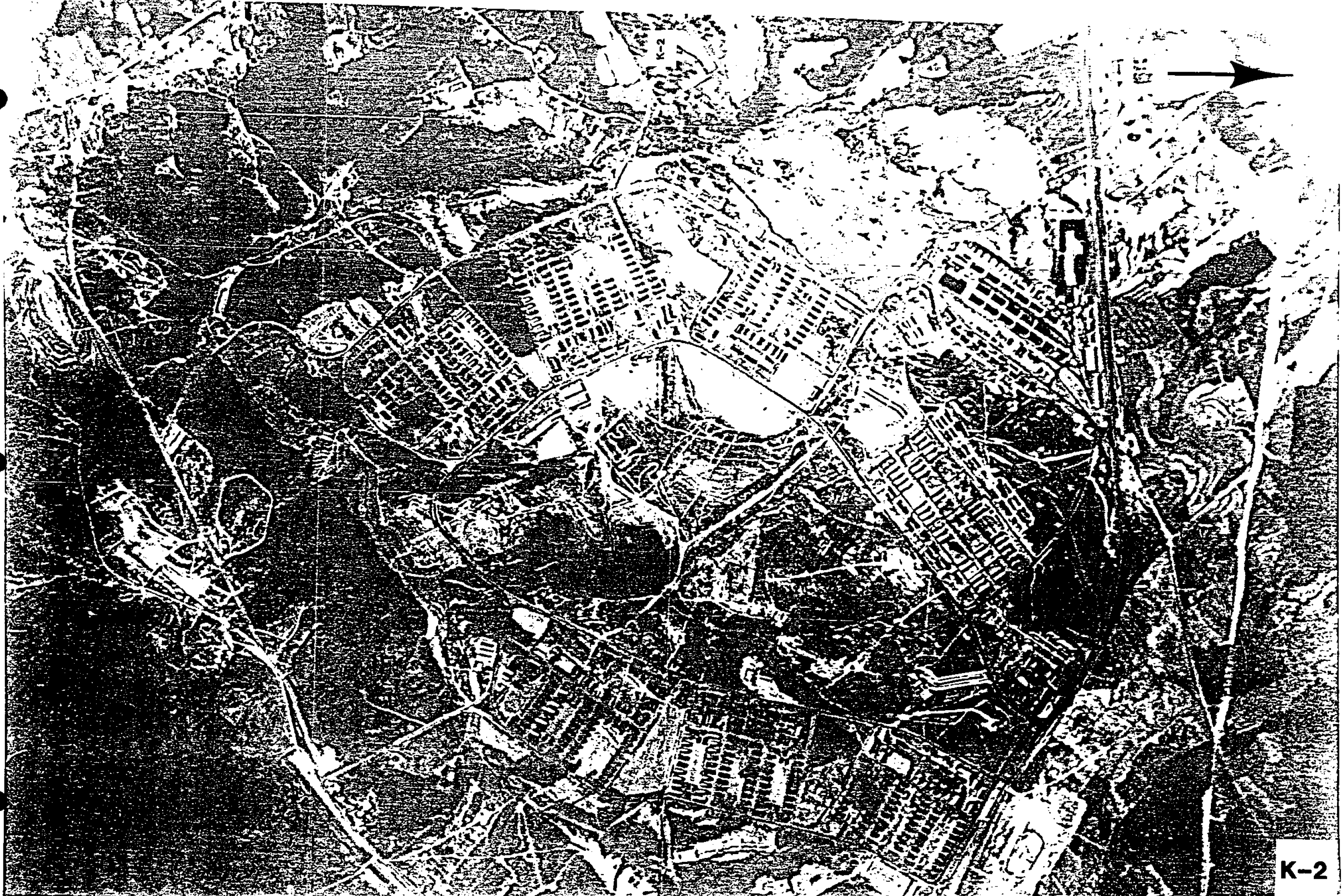

ORDNANCE AND EXPLOSIVE WASTE  
ARCHIVES SEARCH REPORT  
FOR  
FORMER CAMP CROFT ARMY TRAINING FACILITY  
SPARTANBURG, SOUTH CAROLINA  
PROJECT NUMBER I04SC001603

APPENDIX L

HISTORICAL MAPS/DRAWINGS

## APPENDIX L

### HISTORICAL MAPS/DRAWINGS

#### Table of Contents

---

- L-1 Vicinity Map, former Camp Croft Army Training Facility, Spartanburg, SC
- L-2 Site Map, former Camp Croft Army Training Facility
- L-3 Location Map, Infantry Replacement Center, former Camp Croft, SC (Depicts Camp Croft cantonment area and ammunition firing ranges), April 15, 1941
- L-4 Topographic Map, Camp Croft and Croft State Park (formerly Camp Croft cantonment area and ammunition firing ranges)
- L-5 Map, Spartanburg County Planning and Development commission, May 1981 (Details current day street names)
- L-6 Map, War Department, Corps of Engineers, U.S. Army, General Layout of Camp Croft Cantonment Area, February 26, 1943
- L-7 Map, Office of the Quartermaster General, Construction Division, Camp Croft, SC, General Layout of Sanitary Sewer System, March 1, 1941
- L-8 Record Drawings, Work as Built, Office of the Quartermaster General, Construction Division, Camp Croft, 1943
- L-9 Property Map and Records System, Spartanburg County, SC, School District 7, September 29, 1965 (District real property that was formerly a portion of Camp Croft is highlighted)
- L-10 Property Map and Records System, Spartanburg County, SC, School District 6, Date only partially legible-1966 (District real property that was formerly a portion of Camp Croft is highlighted)
- L-11 Property Map and Records System, Spartanburg County, SC, School District 3, April 16, 1965 (District real property that was formerly a portion of Camp Croft is highlighted)
- L-12 Property Plat of Reservation, Camp Croft, SC (Showing location of individual tracts), June 17, 1941 L-13 Drawing No. 1021-7 (four sheets), War Department, Office of the Division Engineer, South Atlantic Division, Camp Croft Military Reservation, January 15, 1946 (Accountability assumed by War Assets Administration [WAA] on 19,044.46 Acres, April 19, 1947; due to final audit September 22, 1949)
- L-14 Map, Camp Croft, SC and Vicinity, Infantry Replacement Training Center, 1944 (Overlay indicates areas restricted to surface use only and location of explosives found)

L-15 General Soil Map, spartanburg County, S.C., Source: Soil Survey, Spartanburg, S.C., dated April, 1968

L-16 Geologic Map, Pacolet 7.5-Minute Quadrangle, Plates 1 and 2, 1985-1988

# VICINITY MAP

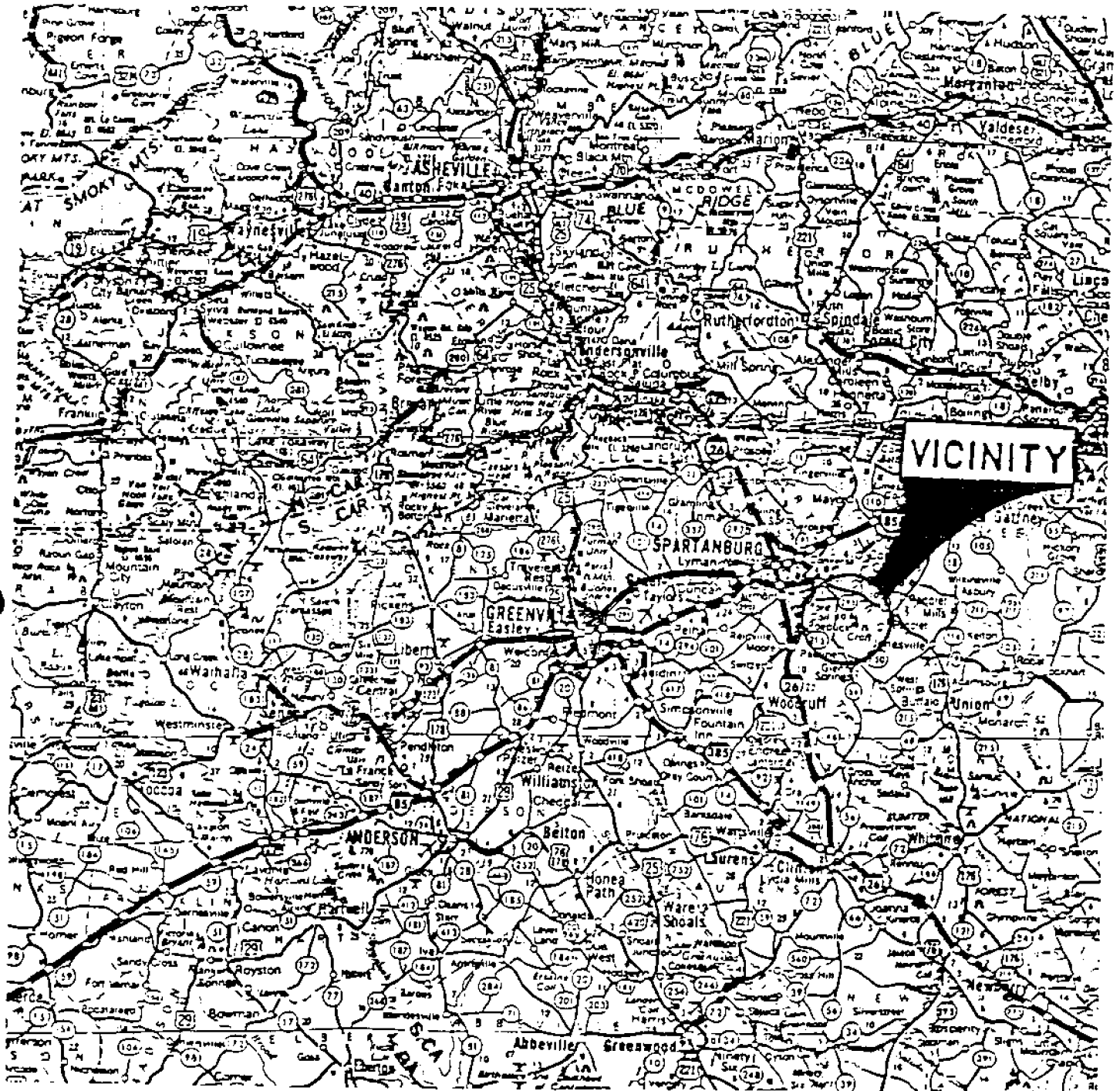

CAMP CROFT ARMY TRAINING FACILITY  
SPARTANBURG COUNTY, SOUTH CAROLINA  
SITE NO. I04SC001600

# SITE MAP

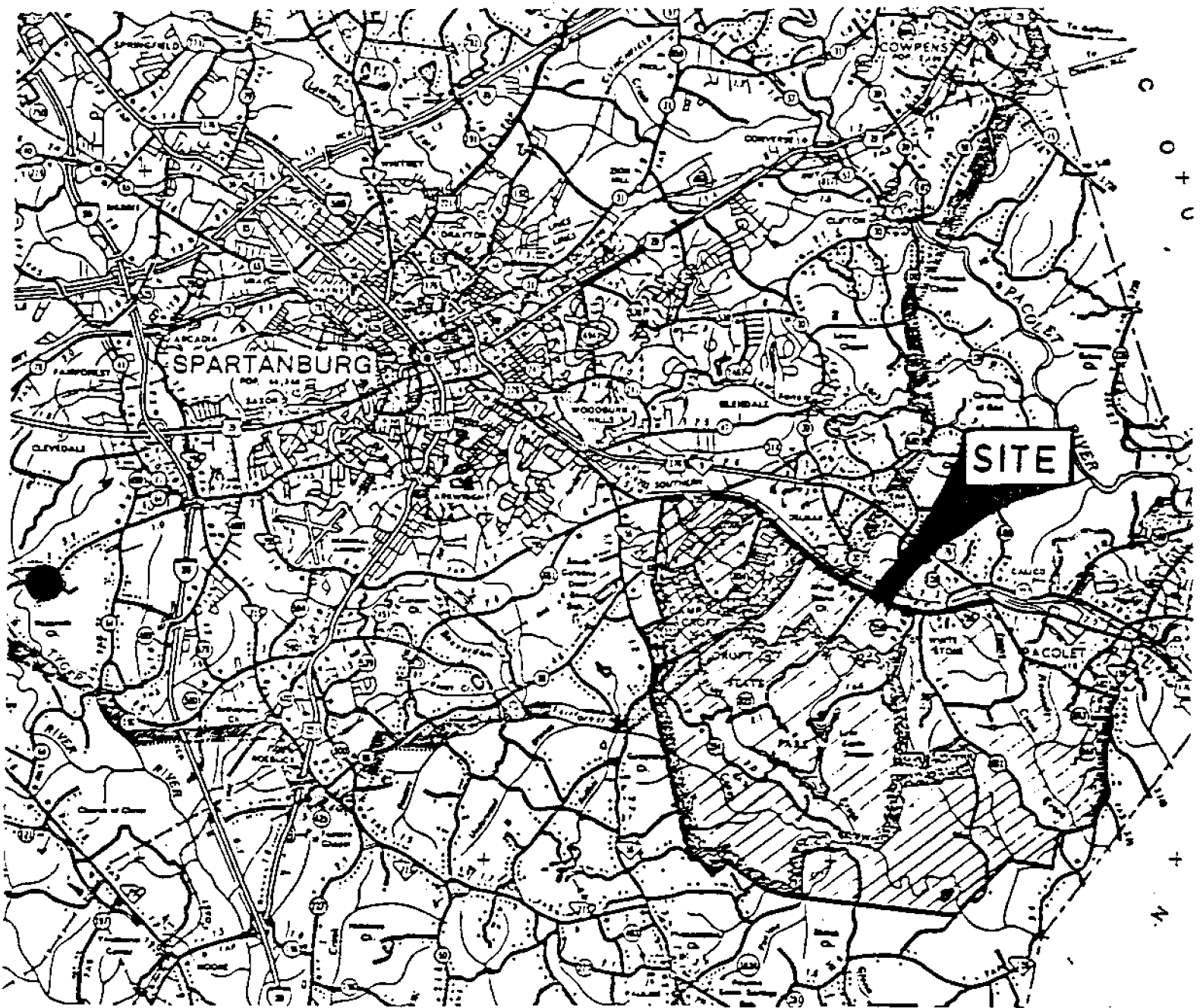

CAMP CROFT ARMY TRAINING FACILITY  
SPARTANBURG COUNTY, SOUTH CAROLINA  
SITE NO. I04SC001600

LEGEND

1. RIFLE - AUTO RIFLE - 200-500 YDS
2. RIFLE - AUTO RIFLE - 200-300-500-1000
3. LANDSCAPE TARGET - 600 FT - 9 SETS
4. AA MINIATURE RANGE - 1000 FT - 3 COMPLETE SETS
5. PISTOL - 500 FT - 120 TARGETS
6. 1000 INCH MACHINE GUN RANGE - 1400 FT
7. RIFLE - AUTO RIFLE - FIELD TARGETS
8. MACHINE GUN - FIELD TARGETS
9. 60MM & 81MM MORTAR
10. 1000 INCH AT
11. MOVING TARGET AT
12. GRENADE COURT
13. BAYONET COURT
14. GAS CHAMBERS
15. COMBAT RANGES

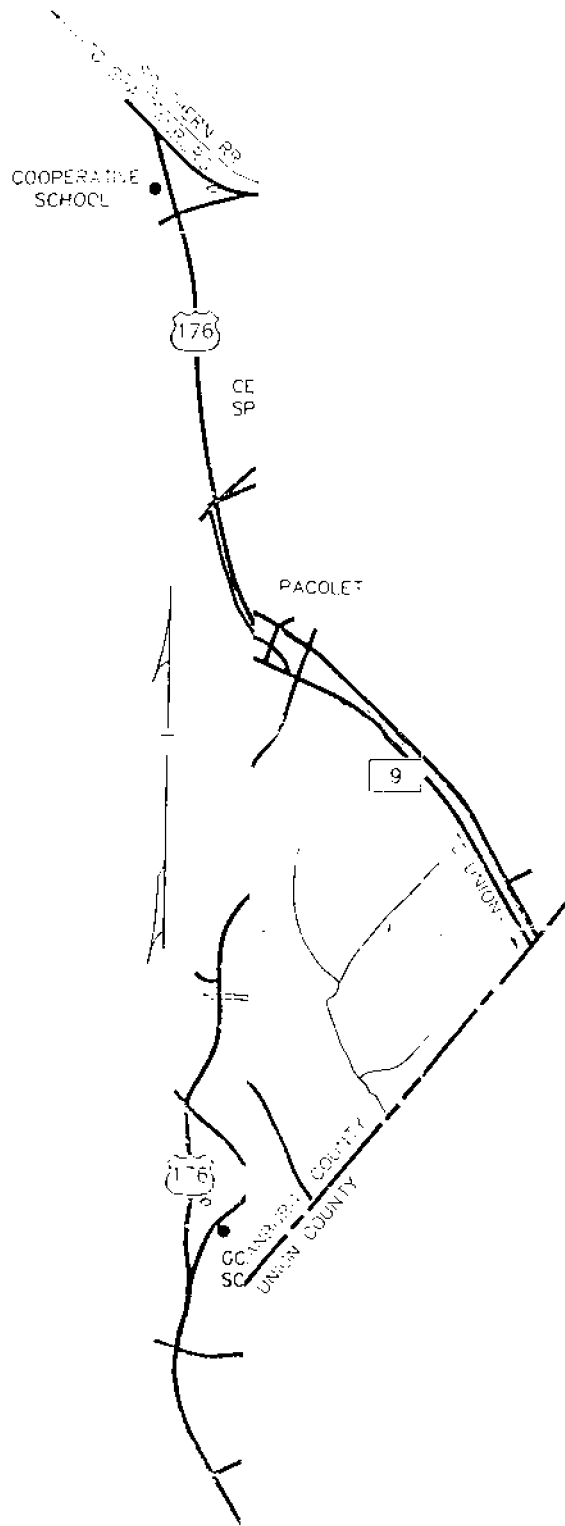

LOCATION MAP

ARMY REPLY CENTER  
CAMP CROFT  
SPARTANBURG, SC

GRAPHIC SCALE

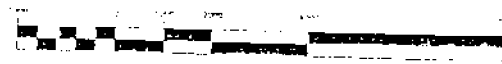

( IN FEET )  
1 inch = 2000 ft

ORDNANCE AND EXPLOSIVE WASTE  
ARCHIVES SEARCH REPORT  
FOR  
FORMER CAMP CROFT ARMY TRAINING FACILITY  
SPARTANBURG, SOUTH CAROLINA  
PROJECT NUMBER I04SC001603

SEE PLATE 2 AND 3



**SPARTANBURG COUNTY  
PLANNING  
&  
DEVELOPMENT  
COMMISSION**  
MAY 1981

Preparation of this map has been financed in part through a grant from the U.S. Dept. of Transportation Federal Highway Administration



**LEGEND**

- State Road
- State Highway
- Interstate
- County Road
- Pvt. Road

A	B	A	B
D	C	D	C
A	B	A	B
D	C	D	C
A	B	A	B
D	C	D	C
A	B	A	B
D	C	D	C

Sheet Index

© 1981

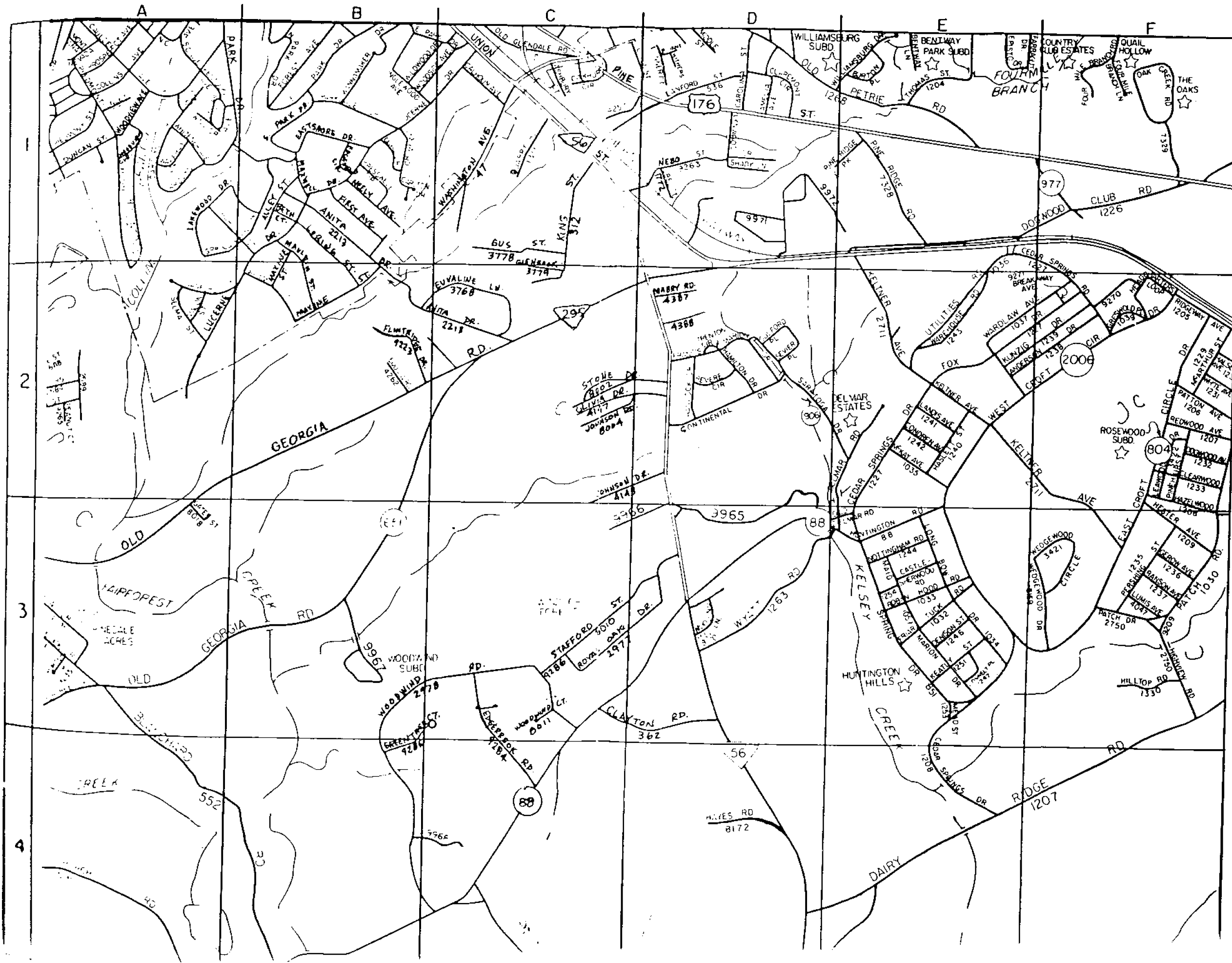





# RECORD DRAWINGS

WORK AS BUILT  
OF

## CAMP-CROFT, S. C.

1943

INDEX	
TITLE OF PLAN	PLAN NO.
RESERVATION MAP	6992-101
GENERAL LAYOUT OF CAMP	- 103
SURVEY CONTROL SHEET	- 104
GENERAL LAYOUT OF WATER MAINS & FIRE HYDRANTS	- 105
SANITARY SEWER SYSTEM	- 106
STORM DRAINAGE	- 107
ELECTRICAL DISTRIBUTION	- 108
STREET LIGHTING SYSTEM	- 109
TELEPHONE CABLE FACILITIES	- 111
GENERAL LAYOUT SHOWING TYPES OF ROADS & STREETS	- 112
1ST REGIMENT LAYOUT AND UTILITIES	- 131
2ND	- 133
3RD	- 135
4TH	- 137
5TH	- 139
6TH	- 141
WAREHOUSE & MOTOR SERVICE LAYOUT AND UTILITIES	- 140
CORPS AREA SERVICE COMMAND	- 143
COAL STORAGE & WATER PUMPING STATION LAYOUT AND UTILITIES	- 146
120 BED HOSPITAL LAYOUT AND UTILITIES	- 149
HQ'S AND REGT & COM OFFICERS QUARTERS LAYOUT AND UTILITIES	- 171
INCINERATOR & SEWAGE PUMPING STATION	- 174
WATER SUPPLY PUMPING STATION BUILDING AND DETAILS	- 180.1
INSTALLATION PLAN AND DETAILS	- 180.2
SEPTIC TANK FOR WATER SUPPLY PUMPING STATION	- 180.3
WATER SUP PUMP STK CONC PUMP BASES & DETAIL OF PIPE FITTINGS	- 181
WATER SUPPLY LINE FROM SPARTANBURG TO STANDPIPE	- 182
DETAILS OF WATER STORAGE TANK AND ALTITUDE VALVE BOX	- 182.1
SPECIAL HEADWALL FOR STANDPIPE DRAIN	- 182.1

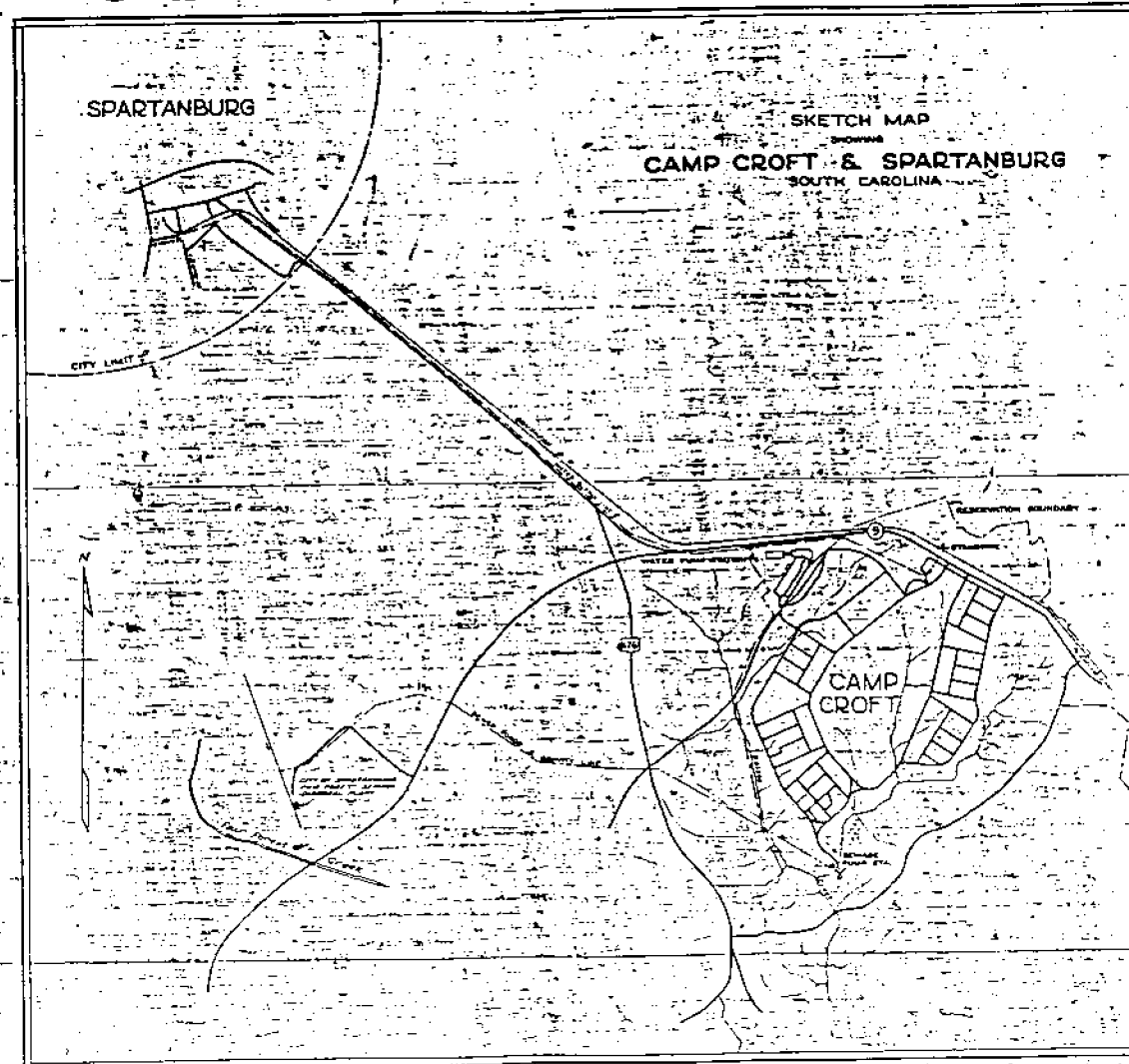

INDEX	
TITLE OF PLAN	PLAN NO.
SEWAGE PUMPING STATION - BUILDING & DETAILS	6992-183
INSTALLATION PLAN & DETAILS	- 183.1
STRUCTURAL PLAN & DETAILS	- 183.2
LOCATION PLAN & VENTURI BOX DETAILS	- 183.3
DETAILS OF EMERGENCY SEWAGE OVERFLOW	- 183.4
FORCE & GRAVITY SAN. SEW. MAIN FROM PUMP STA. TO FARM FOREST DISPOSAL PLANT	- 184
NEW BOX AT STATION 107+58.9 ON 18" GRAVITY SEWER MAIN	- 184.1
TYPICAL SECTIONS OF ROADS AND STREETS	- 180
CONCRETE PAVEMENT	- 180.1
DETAILS OF REINFORCING & JOINTS FOR CONCRETE PAVEMENT	- 180.2
DETAIL OF DROP INLET & CATCH BASIN	- 180.3
DETAILS OF CASTINGS FOR MANHOLES & CATCH BASINS	- 180.4
STANDARD DETAILS FOR CONCRETE HEADWALLS	- 180.5
SECTION OF FRONT WAREHOUSE AREA ROAD	- 180.6
RAILROAD FACILITIES	- 182
REVISIONS TO STANDARD DRAWINGS	- 184
TYPICAL INSTALLATION - STEAM HOT WATER HEATERS WITH CONNECT'GS	- 184.1
DETAILS FOR OVERHEAD PIPE SUPPORT BETWEEN BOILER HOUSE & LAUNDRY	- 185
SPECIAL STACK AND BREACHING DETAILS	- 185.1
CONNECTION DIAGRAM & OPERATION MAP OF ELEC. DISTRIBUTION SYSTEM	- 186
OVERHEAD ELECTRIC DISTRIBUTION CONSTRUCTION - STANDARD DETAILS	- 186.1
DENTAL CLINIC & FIELDHOUSE LAYOUT AND UTILITIES	- 134
CHAUFFEUR SCHOOL & MTR. POOL	- 143
STATION	- 164
INDUCTION STATION	- 168
HEADQUARTERS COMPANY I.R.T.C.	- 170
AMPHITHEATRE & O. CLUB	- 172
OFFICERS CLUB	- 173

CARTER - JONES - BOYLE  
CONTRACTORS

CONSTRUCTION DIVISION  
OFFICE OF THE QUARTERMASTER GENERAL  
MAJOR NEIL R. MCKAY - CONSTRUCTING QUARTERMASTER, U. S. ARMY

HARWOOD BEEBE - CO.  
ARCHITECT-ENGINEER



7 INDEX SHEETS  
 24 400 MAPS  
 192 100 MAPS  
 8 50 MAPS  
 230 TOTAL MAPS

**AERO SERVICE**  
 1501 E. 10th St.  
 Spartanburg, S.C. 29303  
 (803) 533-1111

MAP COMPLETED		REVISIONS	
DATE	BY	DATE	BY

SCALE: 1 INCH = 100 FEET  
 1000' 500' 0' 500' 1000'

LEGEND	

PROPERTY MAP AND RECORDS SYSTEM  
**SPARTANBURG COUNTY, S.C.**  
 SCHOOL DISTRICT 7  
 SHEET INDEX

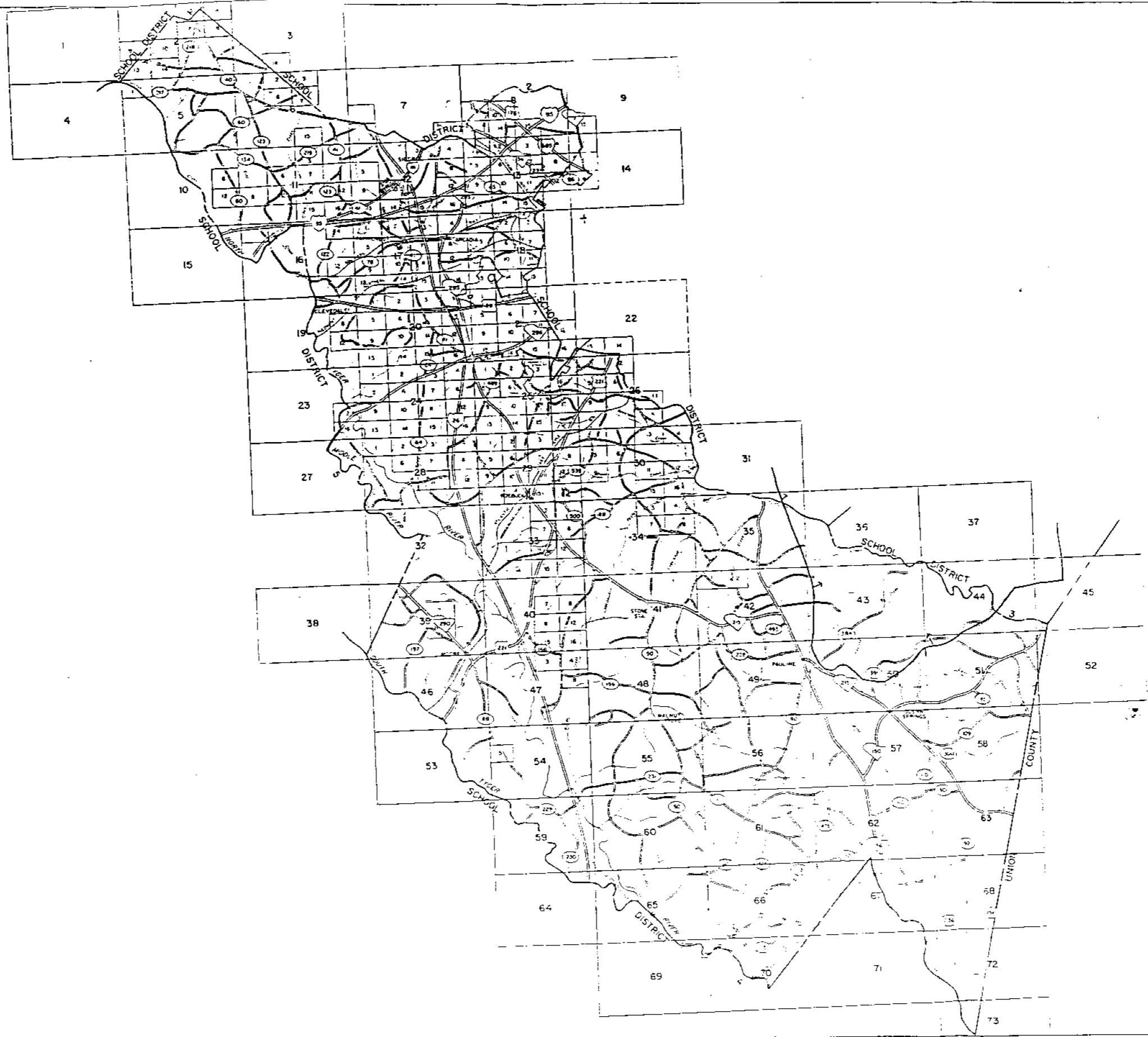

2 INDEX SHEETS  
 72 400 MAPS  
 221 100 MAPS  
 293 TOTAL MAPS

AERO SERVICE 

MAP COMPLETED		REVISIONS		TOTAL SHEETS	
DATE	BY	DATE	BY	DATE	BY

SCALE 1 INCH = 1 MILE

BASE MAP COMPILED BY PHOTOGRAMMETRY. METHOD DATE OF PHOTOGRAPHY MARCH 1963  
 BY AEROSPACE PHOTO RECONNAISSANCE AND RECORDED PLATS  
 SHEET LAYOUT BASED ON THE SOUTH CAROLINA LAMBERT GRID SYSTEM

LEGEND	
	Boundary
	Road
	Water
	School
	Utility

PROPERTY MAP AND RECORDS SYSTEM  
**SPARTANBURG COUNTY, S.C.**  
 SCHOOL DISTRICT 6  
 SHEET INDEX







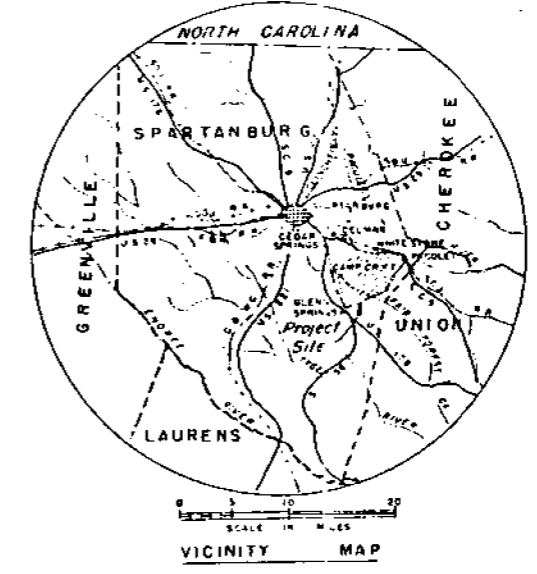
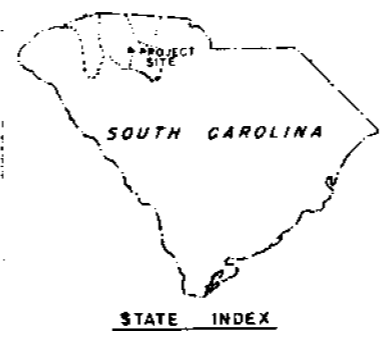
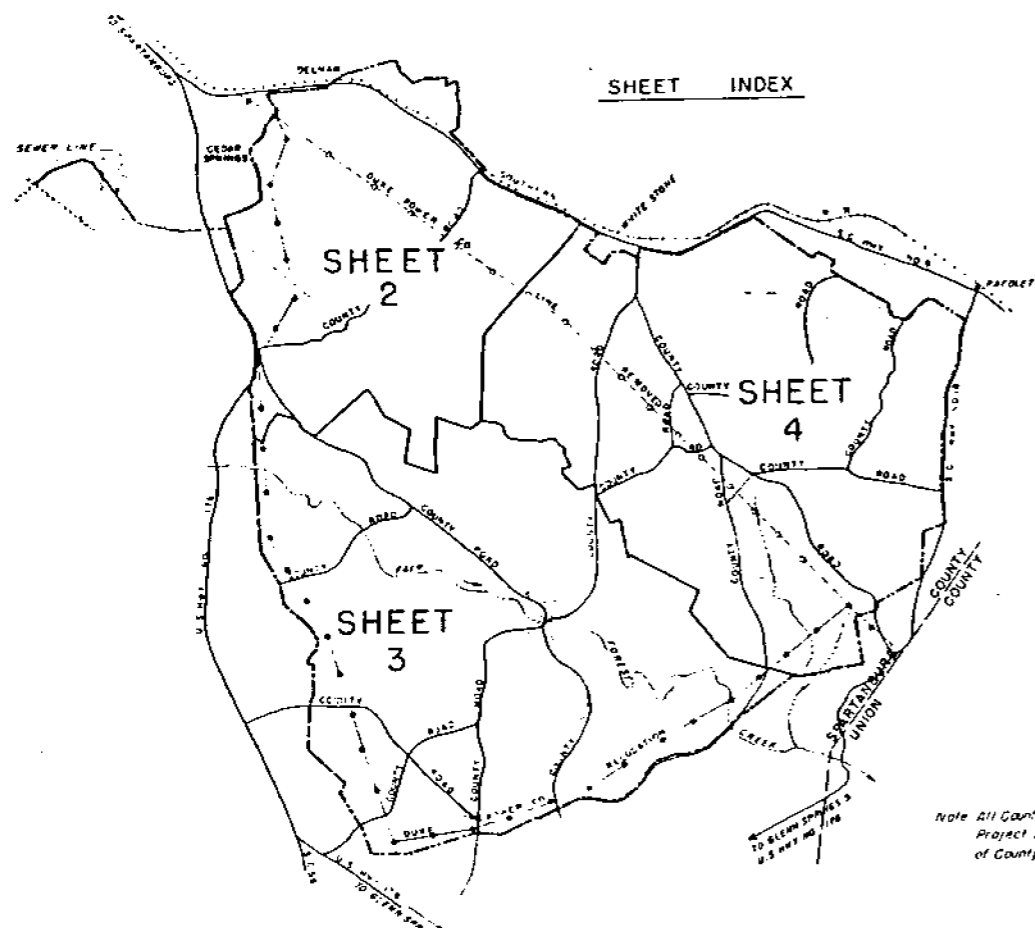

**FINAL PROJECT OWNERSHIP MAP**  
 STATE: SOUTH CAROLINA  
 COUNTY: SPARTANBURG  
 DIVISION: SOUTH ATLANTIC  
 DISTRICT: SAVANNAH  
 THIRD ARMY AREA  
 3 MILES S.E. OF SPARTANBURG  
 0.5 MILES S.W. OF PACOLET

**TRANSPORTATION FACILITIES**  
 SOUTHERN RAILROAD  
 9 & 18 STATE ROAD  
 176 FEDERAL ROAD  
 AIRLINE

**ACQUISITION**  
 TOTAL ACRES IN PROJECT: 19044.46  
 ACRES FEE: 19039.04  
 ACRES EASEMENT: \_\_\_\_\_  
 ACRES LEASED: \_\_\_\_\_  
 ACRES TRANSFERRED TO W.D.: \_\_\_\_\_  
 ACRES LESSER INTERESTS: 3.42  
**DISPOSALS**  
 TOTAL ACRES DISPOSED OF: 13044.46  
 ACRES SOLD: \_\_\_\_\_  
 ACRES TRANSFERRED: \_\_\_\_\_  
 ACRES EXCHANGED: \_\_\_\_\_  
 ACRES LEASER INTERESTS: \_\_\_\_\_  
 ACRES TO W.A.A.: \_\_\_\_\_

**LEGEND**

**ACQUISITION AUTHORIZATION**

RE-D	DATE	DATE
RE-D 1	JAN 1942	1942-01-01
RE-D 2	...	...
RE-D 3	...	...
RE-D 4	...	...
RE-D 5	...	...
RE-D 6	...	...
RE-D 7	...	...
RE-D 8	...	...

**ACQUISITION TRACT REGISTER**

TRACT NO.	SHEET NO.	LAND OWNER	ACRES	ACRES FEE	REMARKS	TRACT NO.	SHEET NO.	LAND OWNER	ACRES	ACRES FEE	REMARKS	TRACT NO.	SHEET NO.	LAND OWNER	ACRES	ACRES FEE	REMARKS
1	2	W. JOSELYN ESTATE	44.50	44.50		103	4	J. L. LEVIN	27.00	27.00		225	2	HENRY SHERBERT	4.70	4.70	
2	2	WALTER W. SIMS BAPTIST CHURCH	0.70	0.70		104	4	JAMES W. L. GLOAN	31.50	31.50		226	2	J. BOUCE SPOUSE ET UX	14.10	14.10	
3	2	MELIA D. PALMER	69.70	69.70		105	4	CHARLES W. MURPH	178.50	178.50		227	2	VIRGINIA S. PICKENS ET AL	28.70	28.70	
4	2	MELIA D. PALMER	69.70	69.70		106	4	LIZZIE SLOAN	28.10	28.10		228	2	M. G. OGLE	18.00	18.00	
5	2	MELIA D. PALMER	69.70	69.70		107	4	D. C. LAWTER	37.30	37.30		229	2	WHITE ST. CHURCH DISTRICT NO 25	40.00	40.00	
6	2	MELIA D. PALMER	69.70	69.70		108	4	J. M. BURGESS	175.00	175.00		230	2	WILLIE ALCKER	16.50	16.50	
7	2	MELIA D. PALMER	69.70	69.70		109	4	JOHN ALLEN	96.00	96.00		231	2	M. J. B. VIOLA E. WHITE	0.54	0.54	
8	2	MELIA D. PALMER	69.70	69.70		110	4	J. F. SLEGAN	90.10	90.10		232	2	A. B. LOCKLER	7.00	7.00	
9	2	MELIA D. PALMER	69.70	69.70		111	4	LIZZIE SLOAN	30.40	30.40		233	2	STATE OF SOUTH CAROLINA	3.10	3.10	
10	2	MELIA D. PALMER	69.70	69.70		112	4	LIZZIE SLOAN	44.40	44.40		234	2	J. BOUCE SPOUSE ET UX	14.10	14.10	
11	2	MELIA D. PALMER	69.70	69.70		113	4	P. L. BILBARD	18.70	18.70		235	2	SPAIN W. MYERS ET UX	15.90	15.90	
12	2	MELIA D. PALMER	69.70	69.70		114	4	IRIS BROWN	23.50	23.50		236	2	MRS. W. H. BAKER	15.90	15.90	
13	2	MELIA D. PALMER	69.70	69.70		115	4	C. E. HODGILL	23.50	23.50		237	2	M. G. WATTS	5.90	5.90	
14	2	MELIA D. PALMER	69.70	69.70		116	4	HOLLYS WIDING	108.00	108.00		238	2	G. W. LEE ET UX	3.40	3.40	
15	2	MELIA D. PALMER	69.70	69.70		117	4	S. T. LIPSON	78.10	78.10		239	2	M. G. WATTS	5.90	5.90	
16	2	MELIA D. PALMER	69.70	69.70		118	4	J. T. COLLIER	172.00	172.00		240	2	M. G. WATTS	5.90	5.90	
17	2	MELIA D. PALMER	69.70	69.70		119	4	J. T. COLLIER	172.00	172.00		241	2	M. G. WATTS	5.90	5.90	
18	2	MELIA D. PALMER	69.70	69.70		120	4	J. T. COLLIER	172.00	172.00		242	2	M. G. WATTS	5.90	5.90	
19	2	MELIA D. PALMER	69.70	69.70		121	4	J. T. COLLIER	172.00	172.00		243	2	M. G. WATTS	5.90	5.90	
20	2	MELIA D. PALMER	69.70	69.70		122	4	J. T. COLLIER	172.00	172.00		244	2	M. G. WATTS	5.90	5.90	
21	2	MELIA D. PALMER	69.70	69.70		123	4	J. T. COLLIER	172.00	172.00		245	2	M. G. WATTS	5.90	5.90	
22	2	MELIA D. PALMER	69.70	69.70		124	4	J. T. COLLIER	172.00	172.00		246	2	M. G. WATTS	5.90	5.90	
23	2	MELIA D. PALMER	69.70	69.70		125	4	J. T. COLLIER	172.00	172.00		247	2	M. G. WATTS	5.90	5.90	
24	2	MELIA D. PALMER	69.70	69.70		126	4	J. T. COLLIER	172.00	172.00		248	2	M. G. WATTS	5.90	5.90	
25	2	MELIA D. PALMER	69.70	69.70		127	4	J. T. COLLIER	172.00	172.00		249	2	M. G. WATTS	5.90	5.90	
26	2	MELIA D. PALMER	69.70	69.70		128	4	J. T. COLLIER	172.00	172.00		250	2	M. G. WATTS	5.90	5.90	
27	2	MELIA D. PALMER	69.70	69.70		129	4	J. T. COLLIER	172.00	172.00		251	2	M. G. WATTS	5.90	5.90	
28	2	MELIA D. PALMER	69.70	69.70		130	4	J. T. COLLIER	172.00	172.00		252	2	M. G. WATTS	5.90	5.90	
29	2	MELIA D. PALMER	69.70	69.70		131	4	J. T. COLLIER	172.00	172.00		253	2	M. G. WATTS	5.90	5.90	
30	2	MELIA D. PALMER	69.70	69.70		132	4	J. T. COLLIER	172.00	172.00		254	2	M. G. WATTS	5.90	5.90	
31	2	MELIA D. PALMER	69.70	69.70		133	4	J. T. COLLIER	172.00	172.00		255	2	M. G. WATTS	5.90	5.90	
32	2	MELIA D. PALMER	69.70	69.70		134	4	J. T. COLLIER	172.00	172.00		256	2	M. G. WATTS	5.90	5.90	
33	2	MELIA D. PALMER	69.70	69.70		135	4	J. T. COLLIER	172.00	172.00		257	2	M. G. WATTS	5.90	5.90	
34	2	MELIA D. PALMER	69.70	69.70		136	4	J. T. COLLIER	172.00	172.00		258	2	M. G. WATTS	5.90	5.90	
35	2	MELIA D. PALMER	69.70	69.70		137	4	J. T. COLLIER	172.00	172.00		259	2	M. G. WATTS	5.90	5.90	
36	2	MELIA D. PALMER	69.70	69.70		138	4	J. T. COLLIER	172.00	172.00		260	2	M. G. WATTS	5.90	5.90	
37	2	MELIA D. PALMER	69.70	69.70		139	4	J. T. COLLIER	172.00	172.00		261	2	M. G. WATTS	5.90	5.90	
38	2	MELIA D. PALMER	69.70	69.70		140	4	J. T. COLLIER	172.00	172.00		262	2	M. G. WATTS	5.90	5.90	
39	2	MELIA D. PALMER	69.70	69.70		141	4	J. T. COLLIER	172.00	172.00		263	2	M. G. WATTS	5.90	5.90	
40	2	MELIA D. PALMER	69.70	69.70		142	4	J. T. COLLIER	172.00	172.00		264	2	M. G. WATTS	5.90	5.90	
41	2	MELIA D. PALMER	69.70	69.70		143	4	J. T. COLLIER	172.00	172.00		265	2	M. G. WATTS	5.90	5.90	
42	2	MELIA D. PALMER	69.70	69.70		144	4	J. T. COLLIER	172.00	172.00		266	2	M. G. WATTS	5.90	5.90	
43	2	MELIA D. PALMER	69.70	69.70		145	4	J. T. COLLIER	172.00	172.00		267	2	M. G. WATTS	5.90	5.90	
44	2	MELIA D. PALMER	69.70	69.70		146	4	J. T. COLLIER	172.00	172.00		268	2	M. G. WATTS	5.90	5.90	
45	2	MELIA D. PALMER	69.70	69.70		147	4	J. T. COLLIER	172.00	172.00		269	2	M. G. WATTS	5.90	5.90	
46	2	MELIA D. PALMER	69.70	69.70		148	4	J. T. COLLIER	172.00	172.00		270	2	M. G. WATTS	5.90	5.90	
47	2	MELIA D. PALMER	69.70	69.70		149	4	J. T. COLLIER	172.00	172.00		271	2	M. G. WATTS	5.90	5.90	
48	2	MELIA D. PALMER	69.70	69.70		150	4	J. T. COLLIER	172.00	172.00		272	2	M. G. WATTS	5.90	5.90	
49	2	MELIA D. PALMER	69.70	69.70		151	4	J. T. COLLIER	172.00	172.00		273	2	M. G. WATTS	5.90	5.90	
50	2	MELIA D. PALMER	69.70	69.70		152	4	J. T. COLLIER	172.00	172.00		274	2	M. G. WATTS	5.90	5.90	
51	2	MELIA D. PALMER	69.70	69.70		153	4	J. T. COLLIER	172.00	172.00		275	2	M. G. WATTS	5.90	5.90	
52	2	MELIA D. PALMER	69.70	69.70		154	4	J. T. COLLIER	172.00	172.00		276	2	M. G. WATTS	5.90	5.90	
53	2	MELIA D. PALMER	69.70	69.70		155	4	J. T. COLLIER	172.00	172.00		277	2	M. G. WATTS	5.90	5.90	
54	2	MELIA D. PALMER	69.70	69.70		156	4	J. T. COLLIER	172.00	172.00		278	2	M. G. WATTS	5.90	5.90	
55	2	MELIA D. PALMER	69.70	69.70		157	4	J. T. COLLIER	172.00	172.00		279	2	M. G. WATTS	5.90	5.90	
56	2	MELIA D. PALMER	69.70	69.70		158	4	J. T. COLLIER	172.00	172.00		280	2	M. G. WATTS	5.90	5.90	
57	2	MELIA D. PALMER	69.70	69.70		159	4	J. T. COLLIER	172.00	172.00		281	2	M. G. WATTS	5.90	5.90	
58	2	MELIA D. PALMER	69.70	69.70		160	4	J. T. COLLIER	172.00	172.00		282	2	M. G. WATTS	5.90	5.90	
59	2	MELIA D. PALMER	69.70	69.70		161	4	J. T. COLLIER	172.00	172.00		283	2	M. G. WATTS	5.90	5.90	
60	2	MELIA D. PALMER	69.70	69.70		162	4	J. T. COLLIER	172.00	172.00		284	2	M. G. WATTS	5.90	5.90	
61	2	MELIA D. PALMER	69.70	69.70		163	4	J. T. COLLIER	172.00	172.00		285	2	M. G. WATTS	5.90	5.90	
62	2	MELIA D. PALMER	69.70	69.70		164	4	J. T. COLLIER	172.00	172.00		286	2	M. G. WATTS	5.90	5.90	
63	2	MELIA D. PALMER	69.70	69.70		165	4	J. T. COLLIER	172.00	172.00		287	2	M. G. WATTS	5.90	5.90	
64	2	MELIA D. PALMER	69.70	69.70		166	4	J. T. COLLIER	172.00	172.00		288	2	M. G. WATTS	5.90	5.90	
65	2	MELIA D. PALMER	69.70	69.70		167	4	J. T. COLLIER	172.00	172.00		289	2	M. G. WATTS	5.90	5.90	
66	2	MELIA D. PALMER	69.70	69.70		168	4	J. T. COLLIER	172.00	172.00							

SEE SHEET 2

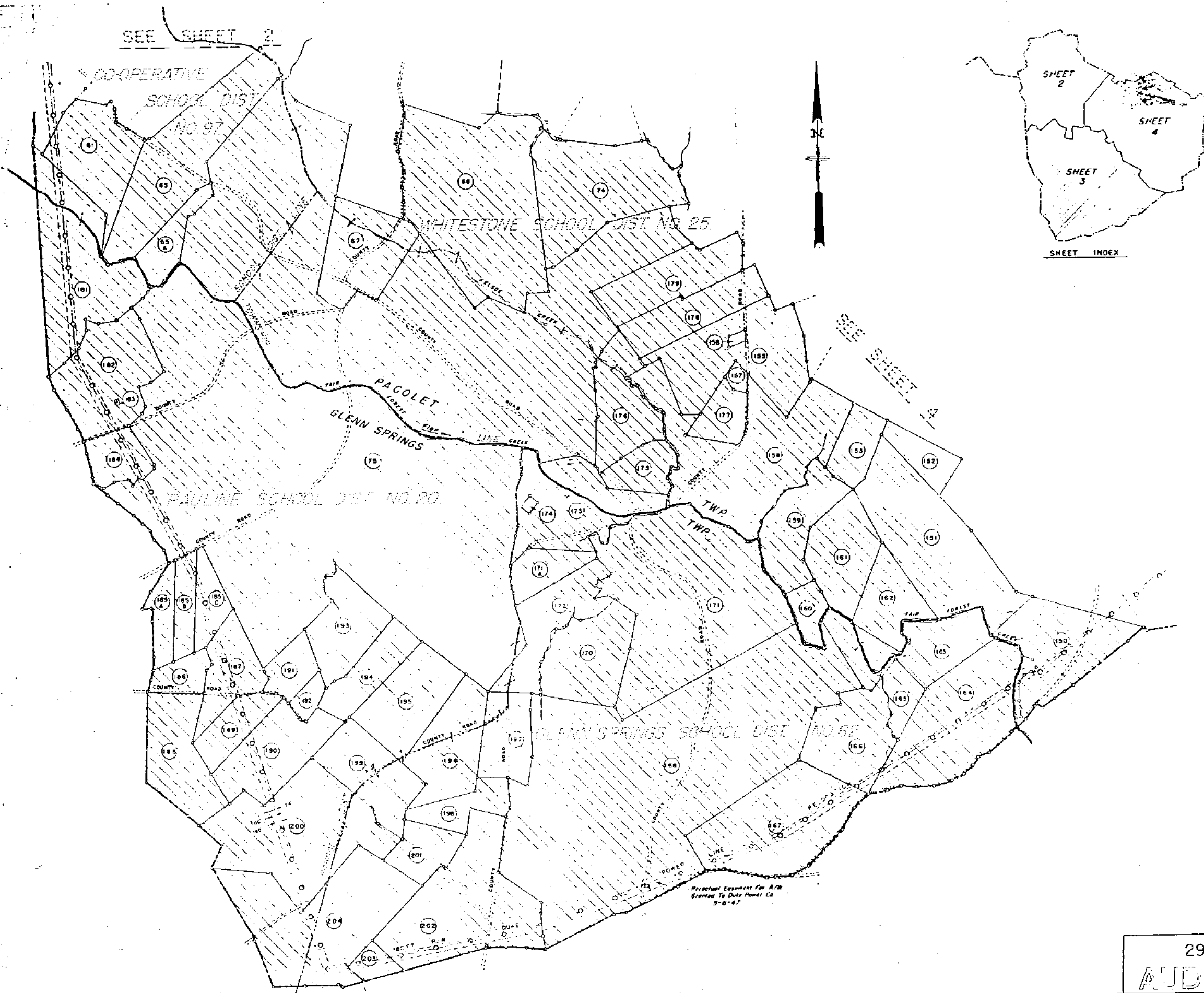

**FINAL PROJECT OWNERSHIP MAP**

STATE SOUTH CAROLINA  
 COUNTY SPARTANBURG  
 DIVISION SOUTH ATLANTIC  
 DISTRICT SAVANNAH  
 THIRD ARMY AREA  
 3 MILES S.E. OF SPARTANBURG  
 0.5 MILES S.W. OF PACOLET

**TRANSPORTATION FACILITIES**

SOUTHERN RAILROAD  
 9 & 18 STATE ROAD  
 176 FEDERAL ROAD  
 AIRLINE

**ACQUISITION**

TOTAL ACRES IN PROJECT  
 ACRES FEE  
 ACRES EASEMENT  
 ACRES LEASED  
 ACRES TRANSFERRED TO W.D.  
 ACRES PERMITS OR LICENSES

**DISPOSALS**

TOTAL ACRES DISPOSED OF  
 ACRES SOLD  
 ACRES TRANSFERRED  
 ACRES EXCHANGED  
 ACRES LEASED FROM W.D.  
 ACRES OTHERWISE

**LEGEND**

- RESERVATION LINE
- STATE OR PROVINCE LINE
- COUNTY LINE
- CIVIL DISTRICT PRECINCT
- LAND GRANT LINE
- CITY, VILLAGE, OR BOROUGH
- CEMETERY, SMALL PARK, ETC
- TOWNSHIP LINE
- SECTION LINE

**RUNWAY APPROACH ZONE AREAS**

- AVIGATION EASEMENT
- FEE SIMPLE

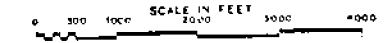

WAR DEPARTMENT  
 OFFICE OF THE DIVISION ENGINEER  
 SOUTH ATLANTIC DIVISION

**CAMP GROFT**

RECOMMENDED DATE  
 APPROVED DATE

COMPILED TRACED CHECKED

DATE BY	REVISIONS	APPROVED
9-22-48 G	DUE TO FINAL AUDIT	

SHEETS 3 OF 4 DRAWING NO. 1021-7

2908  
**AUDITED**



**FINAL PROJECT OWNERSHIP MAP**  
 STATE SOUTH CAROLINA  
 COUNTY SPARTANBURG  
 DIVISION SOUTH ATLANTIC  
 DISTRICT SAVANNAH  
 THIRD ARMY AREA  
3 MILES S.E. OF SPARTANBURG  
0.5 MILES S.W. OF PAGOLET

**TRANSPORTATION FACILITIES**  
 SOUTHERN RAILROAD  
 9 B 18 STATE ROAD  
 176 FEDERAL ROAD  
 AIRLINE

**ACQUISITION**  
 TOTAL ACRES IN PROJECT  
 ACRES FEE  
 ACRES EASEMENT  
 ACRES LEASED  
 ACRES TRANSFERRED TO W.D.  
 ACRES, PERMITS, OR LICENSES

**DISPOSALS**  
 TOTAL ACRES DISPOSED OF  
 ACRES SOLD  
 ACRES TRANSFERRED  
 ACRES EXCHANGED  
 ACRES LEASED FROM W.D.  
 ACRES OTHERWISE

**LEGEND**  
 RESERVATION LINE  
 STATE OR PROVINCE LINE  
 COUNTY LINE  
 CIVIL DISTRICT PRECINCT  
 LAND GRANT LINE  
 CITY, VILLAGE, OR BOROUGH  
 CEMETERY, SMALL PARK, ETC.  
 TOWNSHIP LINE  
 SECTION LINE

**RUNWAY APPROACH ZONE AREAS**  
 AVIGATION EASEMENT  
 FEE SIMPLE

0 300 1000 2000 3000 4000  
 SCALE IN FEET



WAR DEPARTMENT  
 OFFICE OF THE DIVISION ENGINEER  
 SOUTH ATLANTIC DIVISION  
**CAMP CROFT**  
 MILITARY RESERVATION  
 RECOMMENDED: *[Signature]* DATE *1/15/47*  
 APPROVED: *[Signature]* DATE *1/15/47*  
 LT COL. C.E. REAL ESTATE OFFICER

COMPILED: *[Signature]* TRACED: *[Signature]* CHECKED: *[Signature]*  
 DATE BY REVISIONS APPROVED  
 5-22-47 TO FINAL ADJUST *[Signature]*

2908  
**AUDITED**

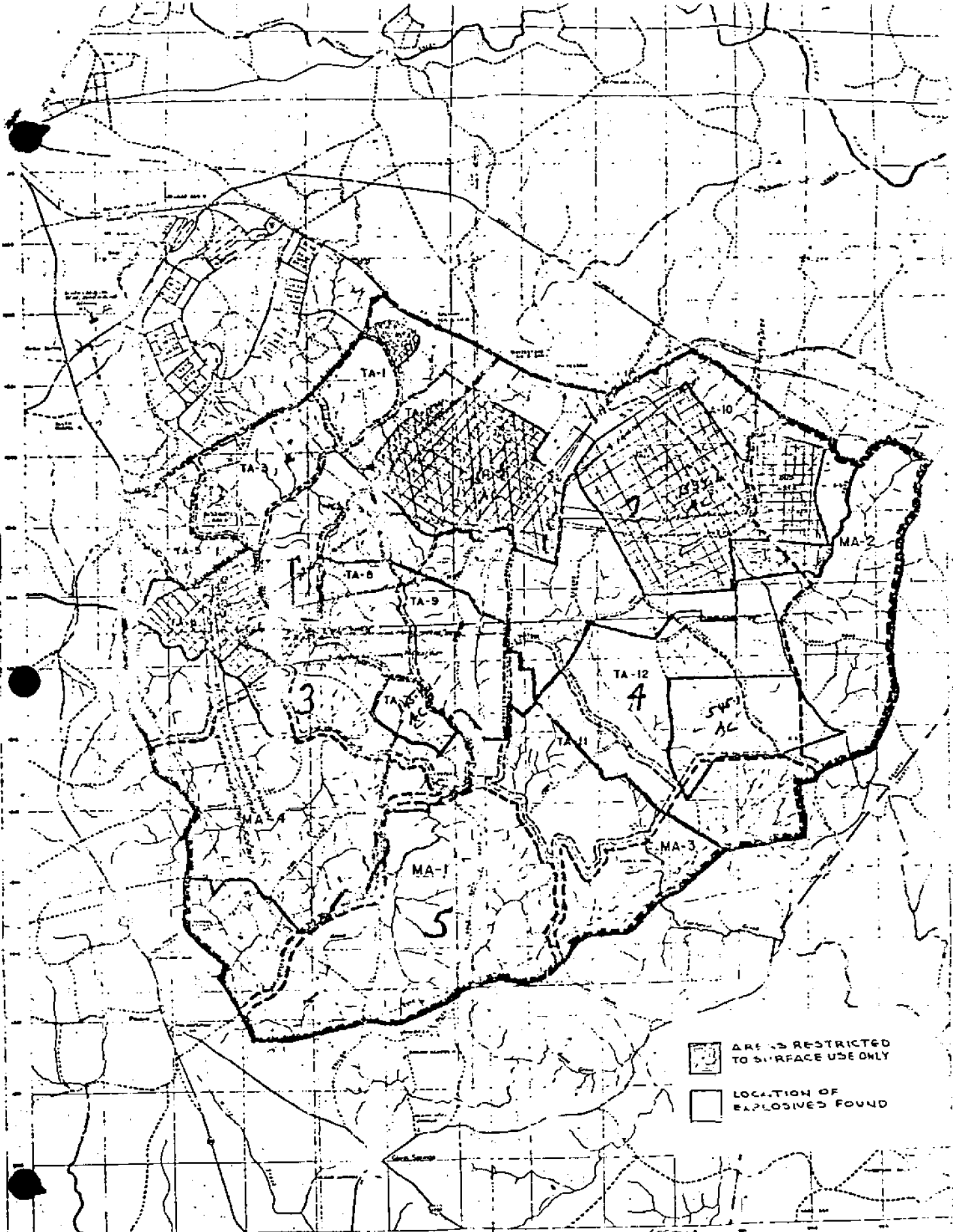
SHEETS: 4 OF 4 DRAWING NO. 1021-7



 AREAS RESTRICTED TO SURFACE USE ONLY  
 LOCATION OF EXPLOSIVES FOUND

This map is the property of the Department of Defense and is loaned to you for your use only. It is not to be distributed outside your organization.

Scale: 1:50,000  
 Contour Interval: 20 Feet  
 Projection: UTM  
 Datum: WGS 84

Legend  
 [Symbol] - Areas Restricted by Department of Defense  
 [Symbol] - Areas Closed by Department of Defense  
 [Symbol] - Areas Closed by Searching

CAMP CROFT, S.C.  
 AND VICINITY  
 Military Replacement Training Center

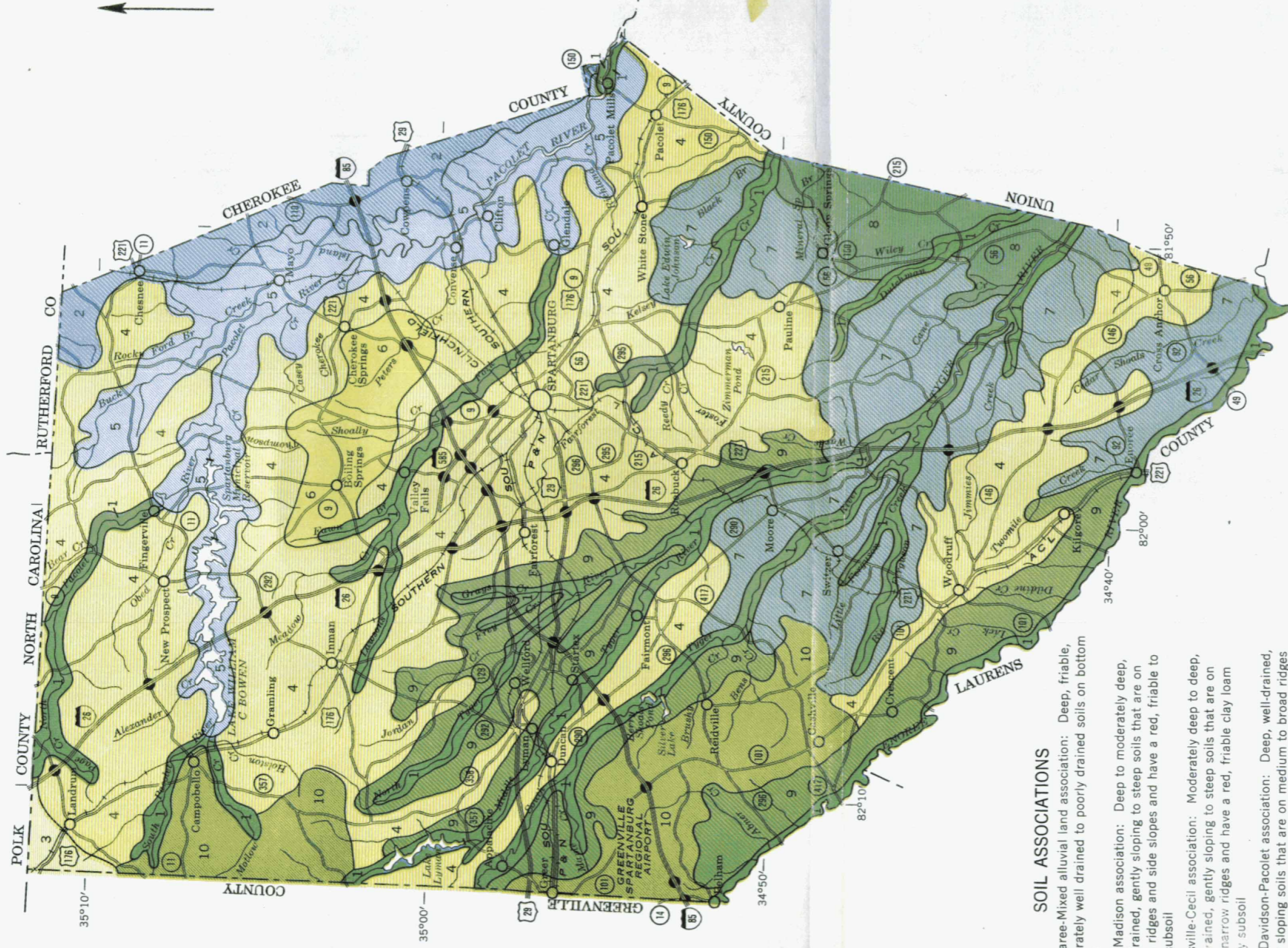

**SOIL ASSOCIATIONS**

- 1 Congaree-Mixed alluvial land association: Deep, friable, moderately well drained to poorly drained soils on bottom lands
- 2 Cecil-Madison association: Deep to moderately deep, well-drained, gently sloping to steep soils that are on broad ridges and side slopes and have a red, friable to firm subsoil
- 3 Hayesville-Cecil association: Moderately deep to deep, well-drained, gently sloping to steep soils that are on long, narrow ridges and have a red, friable clay loam to clay subsoil
- 4 Cecil-Davidson-Pacolet association: Deep, well-drained, gently sloping soils that are on medium to broad ridges and have a red or dark-red, firm clayey subsoil
- 5 Cecil-Museila-Louisburg association: Deep to shallow, well-drained to excessively drained, sloping to steep soils that are on ridges and side slopes and have a clay to loamy sand subsoil
- 6 Cecil-Vance-Applying association: Deep, well drained and moderately well drained, gently sloping soils that are on broad ridges and have a red to brownish-yellow, firm to very firm clayey subsoil
- 7 Cataula-Cecil-Madison association: Deep to moderately deep, moderately well drained to well drained, gently sloping to steep soils that are on irregular ridges and have a red, very firm to firm clayey subsoil
- 8 Davidson association: Deep, well-drained, sloping to strongly sloping soils that are on broad ridges and have a dark-red, firm clay subsoil
- 9 Cecil-Pacolet association: Deep, well-drained, gently sloping to steep soils that are on narrow ridges and side slopes and have a red, firm clayey subsoil
- 10 Cecil-Applying-Pacolet association: Deep, well-drained, gently sloping to moderately steep soils that are on ridges and side slopes and have a red to brownish-yellow, firm clayey subsoil

U. S. DEPARTMENT OF AGRICULTURE  
SOIL CONSERVATION SERVICE  
SOUTH CAROLINA AGRICULTURAL EXPERIMENT STATION

**GENERAL SOIL MAP  
SPARTANBURG COUNTY, SOUTH CAROLINA**



SOUTH CAROLINA GEOLOGICAL SURVEY  
 OPEN-FILE REPORT 64 (1989)

DIVISION OF RESEARCH & STATISTICAL SERVICES  
 S.C. BUDGET & CONTROL BOARD

81°52' 30"  
 33°00'

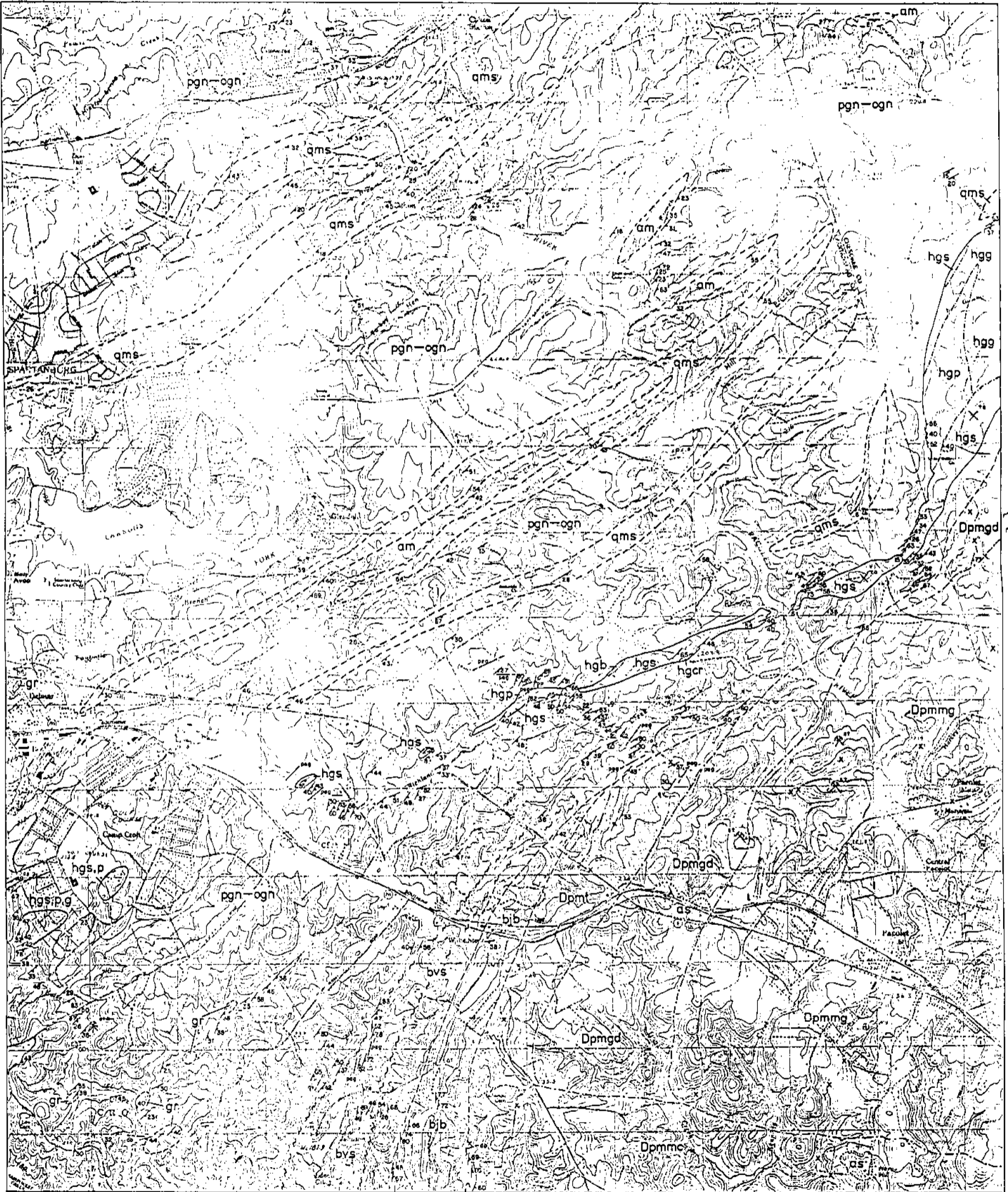

GEOLOGY BY: S.K. MITTWEDE  
 1965-1988

Kings Mountain  
 shear zone

SCALE 1:24000

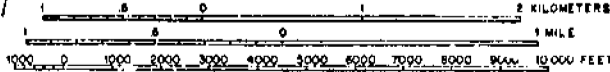

CONTOUR INTERVAL 2 METERS  
 CURVE ELEVATIONS GIVEN TO THE NEAREST 0.1 METER  
 OTHER ELEVATIONS GIVEN TO THE NEAREST METER  
 TO OBTAIN SPACES FOR THIS MAP PLEASE SEE 1:25000  
 TO OBTAIN THE SPACES FOR THIS MAP PLEASE SEE 1:25000

Reconnaissance only in the part of the quadrangle  
 underlain by rocks of the Inner Piedmont belt.

GEOLOGIC MAP OF THE  
 PACOLET 7.5-MINUTE QUADRANGLE

PLATE 1

SOUTH CAROLINA GEOLOGICAL SURVEY  
 OPEN-FILE REPORT 64 (1989)

DIVISION OF RESEARCH & STATISTICAL SERVICES  
 S.C. BUDGET & CONTROL BOARD

Kings Mountain  
 Shear Zone

Jones Creek shear zone

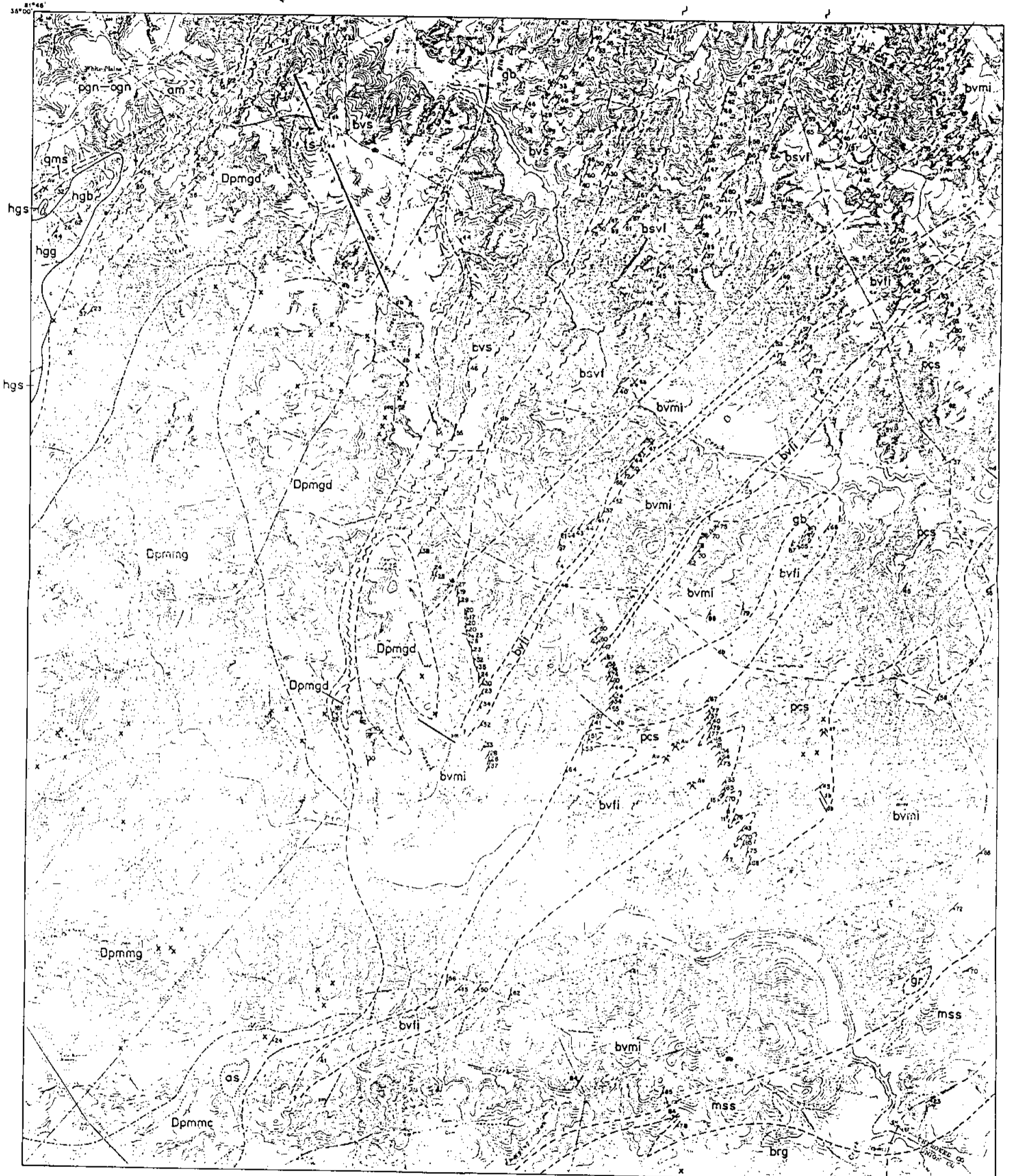

GEOLOGY BY: S.K. MITTWEDE  
 1985-1988

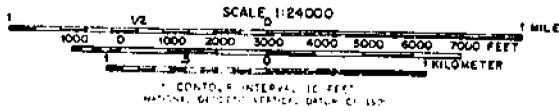

GEOLOGIC MAP OF THE  
 PACOLET MILLS 7.5-MINUTE QUADRANGLE

PLATE 2

Reconnaissance only in the southeastern part of the quadrangle.

ORDNANCE AND EXPLOSIVE WASTE  
ARCHIVES SEARCH REPORT  
FOR  
FORMER CAMP BUTNER  
BUTNER, NORTH CAROLINA  
PROJECT NUMBER I04NC000902

APPENDIX M  
REPORT DISTRIBUTION LIST



ORDNANCE AND EXPLOSIVE WASTE  
 ARCHIVES SEARCH REPORT  
 FOR  
 FORMER CAMP CROFT  
 SPARTANBURG, SOUTH CAROLINA  
 PROJECT NUMBER I04SC001603

APPENDIX M

REPORT DISTRIBUTION LIST

<u>Addressees</u>	<u>No. Copies</u>	
	Draft	Final
Commander, U.S. Army Corps of Engineers ATTN: CEMP-RF (Sailor/Coppola) Pulaski Building 20 Massachusetts Avenue NW. Washington, D.C. 20313-1000	-	2
Commander, U.S. Army Engineer Division ATTN: Huntsville, ATTN: CEHND-PM-OT, P.O. Box 1600, Huntsville, Alabama 35807-4301	3	3
Commander, U.S. Army Engineer Division North Central, ATTN: CENCD-PE-ED-TE 111 North Canal Street, Chicago, Illinois 60606-7205	1	3
Commander, U.S. Army Engineer District Charleston, ATTN: CESAC-EN-PR P.O. Box 919 Charleston, South Carolina 29402-0919	1	1
Commander, U.S. Army Defense Ammunition Center and School, ATTN: SMCAC-ES Savanna, Illinois 61074-9639	1	2
Commander, U.S. Army Health Clinic, ATTN: HSXZ-PS-RIA (Platt), Rock Island Arsenal, Rock Island, Illinois 61201	-	1

ORDNANCE AND EXPLOSIVE WASTE  
ARCHIVES SEARCH REPORT  
FOR  
FORMER CAMP CROFT  
SPARTANBURG, SOUTH CAROLINA  
PROJECT NUMBER I04SC001603

APPENDIX M

REPORT DISTRIBUTION LIST

<u>Addressees</u>	<u>No. Copies</u>	
	Draft	Final
CENCR-ED	1	1
-ED-D	1	1
-ED-DN	1	1
-SO	1	1
-ED-G	1	1
-ED-H	1	1
-PD	1	1
-RE	1	1

ORDNANCE AND EXPLOSIVE WASTE  
ARCHIVES SEARCH REPORT  
FOR  
FORMER CAMP CROFT ARMY TRAINING FACILITY  
SPARTANBURG, SOUTH CAROLINA  
PROJECT NUMBER I04SC001603

PLATES







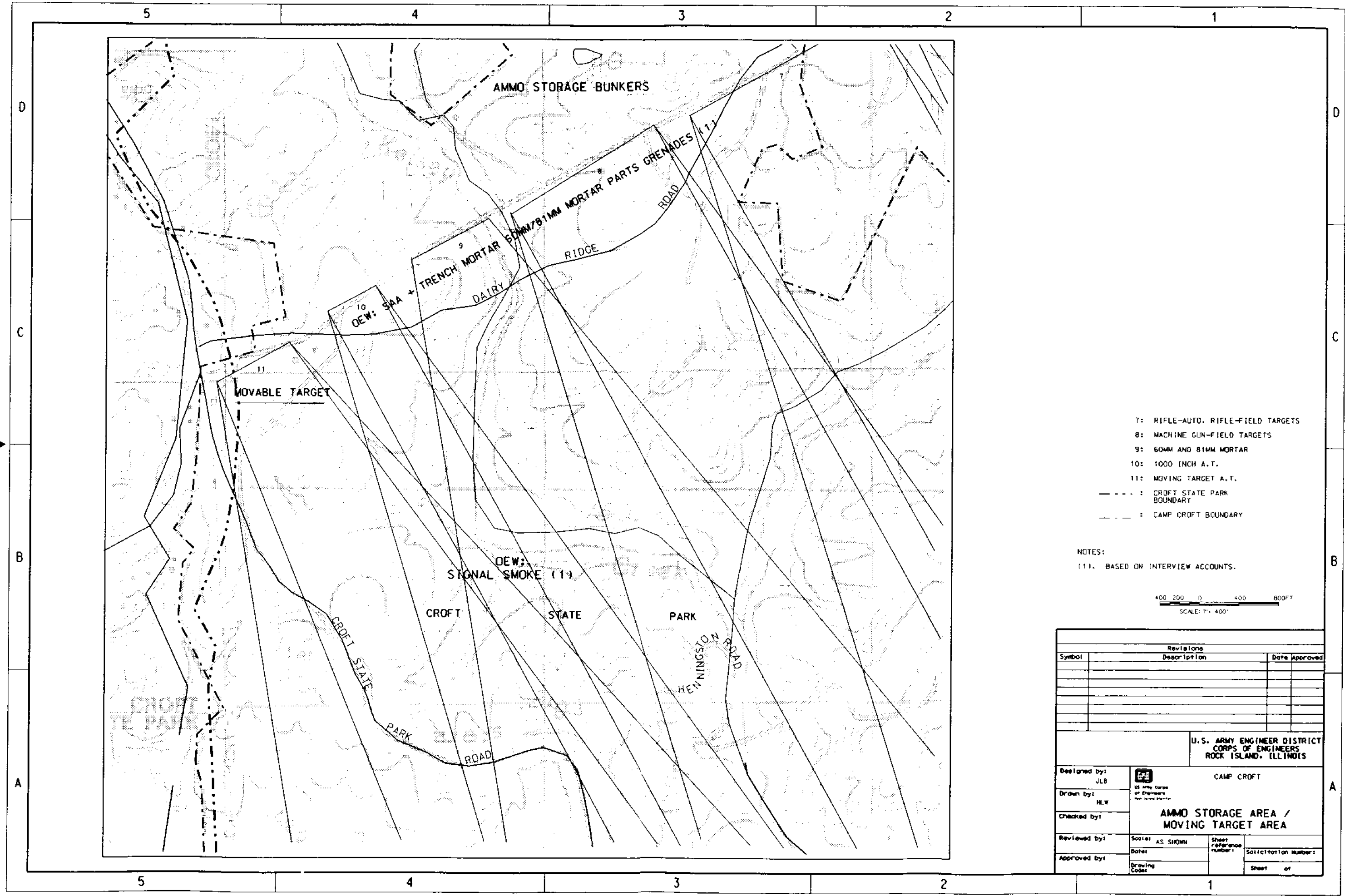

- 7: RIFLE-AUTO. RIFLE-FIELD TARGETS
- 8: MACHINE GUN-FIELD TARGETS
- 9: 60MM AND 81MM MORTAR
- 10: 1000 INCH A.T.
- 11: MOVING TARGET A.T.
- - - - : CROFT STATE PARK BOUNDARY
- - - - : CAMP CROFT BOUNDARY

NOTES:  
 (1). BASED ON INTERVIEW ACCOUNTS.

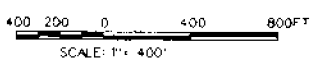

Revisions		
Symbol	Description	Date Approved

U.S. ARMY ENGINEER DISTRICT  
CORPS OF ENGINEERS  
ROCK ISLAND, ILLINOIS

Designed by: JLB  
 Drawn by: HLW  
 Checked by:      **CAMP CROFT**  
 Reviewed by:      **AMMO STORAGE AREA / MOVING TARGET AREA**  
 Approved by:      **AS SHOWN**

Sheet reference number:      Solicitation number:      Sheet of

28-SEP-1983 09:15 /usr/jrc/epa/epa01/epd003.ggn

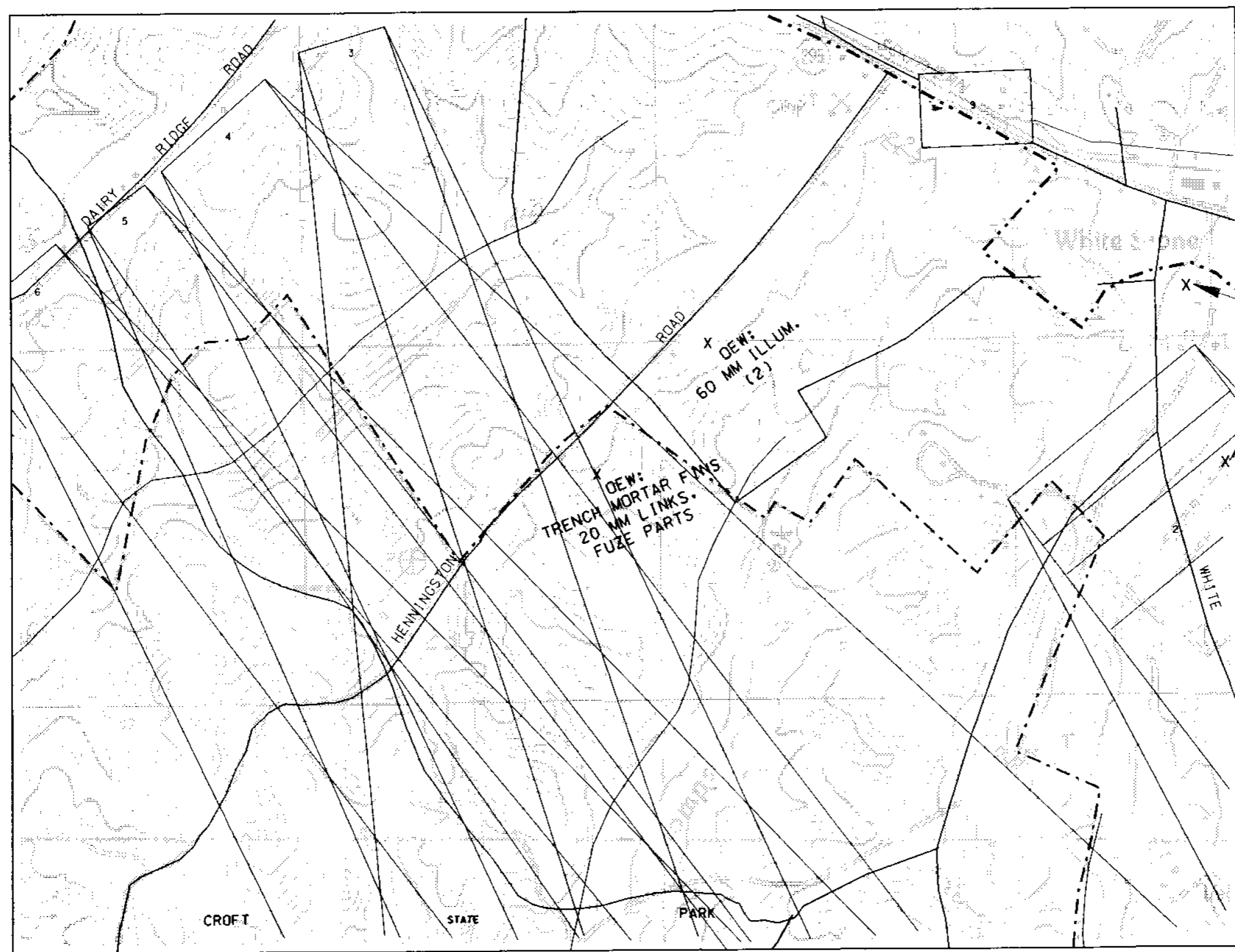

PRESENT DAY FACTORY

RIFLE TARGET BURM

- 2: RIFLE-AUTO. RIFLE- 200-300 YDS
- 3: LANDSCAPE TARGET-600 FT-9SETS
- 4: AA MINIATURE RANGE-1080 FT-3 COMPLETE SETS
- 5: PISTOL-660 FT. 120 TARGETS
- 6: 1000 INCH MACHINE GUN RANGE 1200 FT
- 9: 60MM AND 81MM MORTAR
- - - CROFT STATE PARK BOUNDARY
- - - CAMP CROFT BOUNDARY

NOTES:  
 (2). VERIFIED BY SI TEAM.

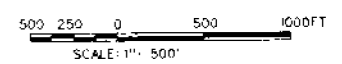

Revisions		
Symbol	Description	Date Approved

U.S. ARMY ENGINEER DISTRICT CORPS OF ENGINEERS ROCK ISLAND, ILLINOIS			
Designed by: JLB	CAMP CROFT		
Drawn by: HLW	HENNINGSTON ROAD AREA		
Checked by:	Scale: AS SHOWN	Sheet reference number:	Solicitation Number:
Reviewed by:	Date:	Sheet of	
Approved by:	Drawing Codes:		

14-567-1993 08117  
 usr-project/ab07/ab07a004.dgn



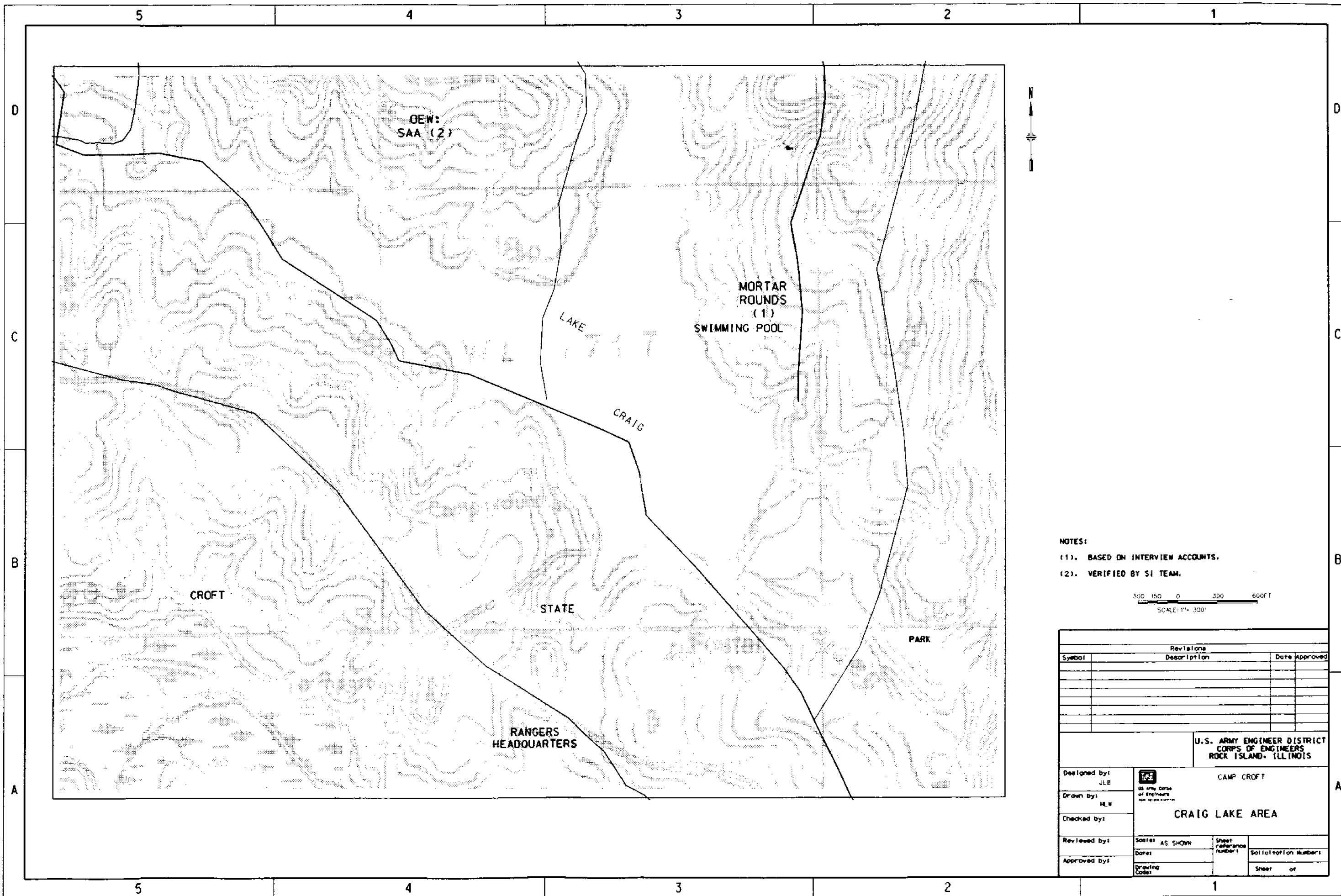

**NOTES:**

- (1). BASED ON INTERVIEW ACCOUNTS.
- (2). VERIFIED BY SI TEAM.

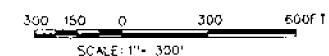

Revisions			
Symbol	Description	Date	Approved

Designed by: JLB		U.S. ARMY ENGINEER DISTRICT CORPS OF ENGINEERS ROCK ISLAND, ILLINOIS	
Drawn by: HLW		CAMP CROFT	
Checked by:		CRAIG LAKE AREA	
Reviewed by:	Scale: AS SHOWN	Sheet reference number:	Solicitation number:
Approved by:	Date:	Sheet of	Sheet of
Drawing Code:		Sheet of	

SEP-1993 09:18  
c:\arc\mca\8607\86070005.dwg

